



Sinhgad Institutes

National Level Student Conference

# IEEE TECHNICOKNOCKDOWN-2023

## TKD-23

Organised by Department of E&TC, SIT Lonavala

Technically Sponsored by

IEEE Bombay Section & IETE, Pune Center

MAY 04, 2023



ISBN NO. 978-81-992245-4-3

Supported by

IEEE SITSB & IETEISF





## National Level Student Conference



# "IEEE TECHNICOKNOCKDOWN-2023 (TKD-23)"

Organized by Department of E&TC, SIT Lonavala



Technically Sponsored by IEEE Bombay Section and IETE, Pune Local Center



Supported by IEEE SITSB & IETEISF, SIT Lonavala

**May 04, 2023**

**(Online mode)**

**Theme: Next Generation Networks**



### Chief Patron

**Hon Prof. M. N. Navale**, Founder President, STE Society, Pune

**Hon Dr. (Mrs) S. M. Navale**, Founder Secretary, STE Society, Pune

**Hon Ms. Rachana Navale Ashtekar**, Vice-President (Admin), STE Society, Pune

**Hon Rohit M. Navale**, Vice President (HR), STE Society, Pune

### Organizing Chair

**Dr. M.S. Gaikwad** Director, STES Campus, Lonavala

Principal, Sinhgad Institute of Technology, Lonavala

**Dr. D.D. Chaudhary**, Vice-Principal & HOD, Dept. of E&TC, SIT, Lonavala, Contact: +91-9372810161

### Conveners

**Dr. D. S. Mantri**, Professor, Dept. of E&TC, SIT, Lonavala Contact: +91-9922431612

**Mr. P. R. Dike**, Asst Professor, Dept. of E&TC, SIT, Lonavala, Contact: +91-9422014174

### Coordinator

**Ms. P. S. Mhetre**, Asst. Professor, Dept. of E&TC, SIT, Lonavala [9404249846]

**Mr. M. K. Bhosale** Asst. Professor, Dept. of E&TC, SIT, Lonavala [7588628575]

### Student Branch Chairs

**Aniket Lamkhade**, Chair IEEE SB, Lonavala, Contact: +91- 9130043090

**Lokesh Singh**, Chair IETE ISF SB, Lonavala, Contact: +91- 8320247541



# Contents

- A. Welcome to TECHNICOKNOCKDOWN-2023
- B. About Sinhgad Institutes and SIT
- C. Mission & Vision
- D. Messages from Different Dignitaries
- E. Organising committee
- F. List of Reviewers
- G. TKD-23 Schedule
- H. List of Authors
- I. Track wise presented Papers



# Welcome to

## TECHNICOKNOCKDOWN-2023

It is our great pleasure to welcome you all for the virtual “**TECHNICOKNOCKDOWN-2023 (TKD-23)**” National Level Students Conference for technical paper presentation on May 04, 2023. The TKD-23 is organized by Department of Electronics and Telecommunication Engg, Sinhgad Institutes of Technology, Lonavala, Pune, Maharashtra. The conference is technically sponsored by IEEE Bombay Section and IETE, Pune local center and supported by IEEE SITSB and IETEISF, SIT Lonavala. TKD-23 provides an ideal platform for exchange of ideas among researchers, students, and practitioners.

TECHNICOKNOCKDOWN-2023 received research papers from all over India. TKD-23 received more than 97 papers out of which 37 regular papers are selected for the oral presentations after peer review. The registered and presented papers are published in IEEE TKD-23 proceeding with ISBN No. 978-81-992245-5-0.

We hope that you will find this event interesting and thought provoking. TKD-23 will provide you with a valuable opportunity to share ideas with other researchers, students, and practitioners from institutions. We look forward to the contribution towards the event and see you virtually.

Team  
TECHNICOKNOCKDOWN-2023

## About STES:

Sinhgad Technical Education Society (STES) was set up in August 1993, under the able and dynamic leadership of Prof. M.N. Navale with an objective of providing quality education in the field of Engineering, Dentistry, Management, Computer, Pharmacy, Architecture, Hotel Management and the basic school education from kinder garden onwards. There are 58 institutes under the aegis of STES offering full-fledged school education, Diploma, Graduation, Post-Graduation courses and Ph.D. programs in various branches of Engineering, Science and Management at five educational campuses ideally located in pollution free lush green and picturesque environment conducive for learning. ([sit.sinhgad.edu](http://sit.sinhgad.edu)).

## About SIT, Lonavala

Sinhgad Institute of Technology (SIT), Lonavala since its establishment in 2004 is involved in practicing teaching-learning methodologies of excellence to deliver quality engineering education for students all over India. The institute is housed in beautiful surroundings, fully residential campus of 200 acres on Pune-Mumbai expressway at Lonavala. Academic discipline with space for individual innovations, emphasis on life skill development of students, 'willing to work' team of faculty members and initiative for Industry interface, have been the silent activity of the college. Institute has following branches;

1. E&TC, Engineering
2. Mechanical Engineering,
3. Electrical Engineering,
4. Computer Engineering,
5. Information Technology &
6. Masters in Electrical and Power Systems

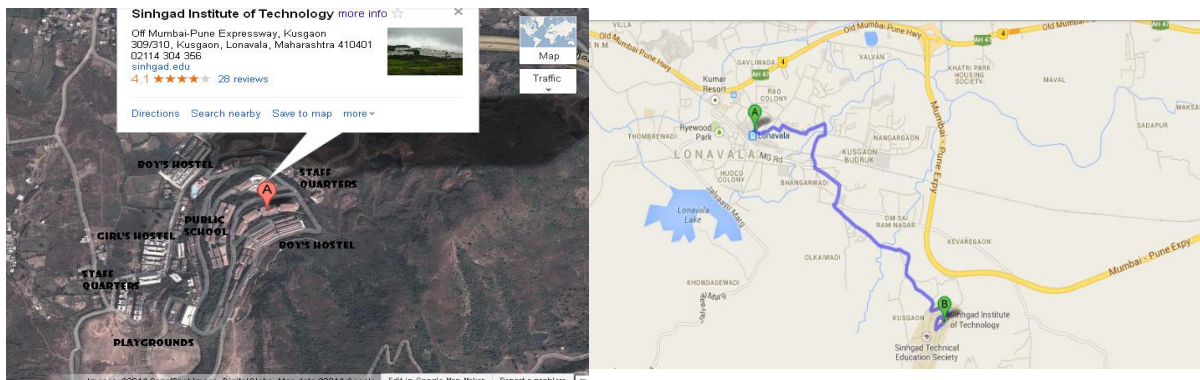



## Vision and Mission of the Institute

### VISION

उत्तमपुरुषान् उत्तमाभियंतृन् निर्मातुं कटीबध्दाः वयम्।

We are committed to produce not only good engineers but good human beings, also.

### MISSION

Holistic development of students and teachers. We strive to achieve this by imbibing a unique value system, transparent work culture, excellent academic and physical environment conducive to learning, creativity and technology transfer.

## Vision and Mission of the Department

### VISION

The department of Electronics & Telecommunication is committed to grow on a path of delivering distinctive high quality education, fostering research, creativity and innovation.

### MISSION

- The department of Electronics & Telecommunication in partnership with all stake holders will harness Talent, Potential for application based indigenous product development in future.
- Our Endeavour is to provide conducive environment for life skill development of students while exercising effective Learning Strategies.

### Short Term Goals

- To improve the results of UG classes
- To implement activity plan for overall development of students.
- To establish professional bodies/students forum for life skill development and expose students and faculty to latest business environment.
- To initiate relevant value addition programs and certifications for improving employability.
- To develop Laboratories for meaningful implementation of curriculum and then for Research.
- To encourage continuous up gradation of faculty members through higher education and external interface with other universities.

### Long Term Goals

- To practice Project Based Learning (PBL) approach for UG program by creating collaborations with national and International institutions of reputation.
- To create opportunities for students to expose to industry environment through value addition programs and Industry projects for practical training.
- To foster research in the field of Electronics and Telecommunication Engineering for the benefit of society.
- IEEE International conference in the area of Wireless communication.



### **Program Educational Objectives (PEOs)**

- PEO1** To develop students to achieve high level of technical expertise with Strong theoretical background and sound practical knowledge
- PEO2** To inculcate research environment for enhancement of Academia – Industry collaboration through conference
- PEO3** To prepare graduates to be sensitive to ethical, societal and Environmental issues while engaging their professional duties, Entrepreneurship and leadership.
- PEO4** To enhance ability of students for providing Engineering solution in a global and societal context
- PEO5** Pursue higher education for professional development.

### **Program Specific Outcomes (PSOs)**

- PSO1** Get solid foundation in design and development of electronics modules useful to society.
- PSO2** Able to handle skills based challenges

**Department Team — always ready to accept challenge**



## Principal's Message



Dear Friends,

I am extremely delighted to assert that Sinhgad Institute of Technology (SIT) is hosting a National level student conference “IEEE Technicoknockdown-2023” on May 04, 2023 at Sinhgad Technical Education Societies (STES) Campus Lonavala.

The TKD-23 has Theme of “Next Generation Networks”, and is very much aligned with the recent technological developments to 5G, 6G, Human Bond Communications and Industry 5.0 etc. The information and communication technology has made a profound impact on almost all sphere of social and personal life of human. The impact of these technologies is likely to continue unabated, therefore it is important that educators, scholars and technocrats keep themselves abreast with the latest trend of technologies. I am sure that the gap between industry and institute will be narrowed by these initiatives enabling mutual benefits and growth I believe that this conference will be an outstanding event for thousands of decision and policy makers , academicians , technocrats and educators.

I congratulate all my participants who have come from various colleges .I assure very delegate attending this event will experience the best academic ambience, hospitality and state of art infrastructural facilities. I am sure that the time spent by you all at Technicoknockdown-23.

A handwritten signature in blue ink, which appears to be 'M. S. Gaikwad', is located below the main text of the message.

**Dr. M. S. Gaikwad**  
Director STES Lonavala campus &  
Principal, SIT, Lonavala



## Message from Vice-Principal & HoD EnTC



On behalf of the institution, I am very happy to publish this issue of **TECHNICO KNOCKDOWN-2023** for the academic year 2022-2023. This event is in collaboration with IEEE and IETE student's branch of our Institute. Sinhgad Institute of Technology, Lonavala is established with the aim of providing quality education at par with international standards. In the recent era of engineering technology it is necessary to have overall personality development of the students and this issue may work as a booster for the same.

This very event is the outcome of the student's consistent effort in regular curricular activities. At SIT our goal is to produce a workforce of technocrats and administrators who will be globally acceptable for their technological skills, their quality of work and their hard work. We also support to develop their basic philosophy of life to live with honour and dignity. The papers presented here may lead to right path of innovation. I really appreciate the efforts taken by the all the members of organizing committee and the students for exploring the excellent quality of this issue.

A handwritten signature in blue ink, which appears to read 'D. Chaudhary'.

**Dr. D.D. Chaudhary**  
Vice-Principal &  
HoD of EnTC Deptt.



## Convener's Message



Dear All,

It gives me an immense pleasure to thank all the participants and working team contributed in the virtual National Level Student Conference for technical paper presentation, “**TECHNICOKNOCKDOWN-2023**” with theme “**Next Generation Networks**” on May 04, 2023. TKD-23 is hosted by Department of Electronics and Telecommunication Engg, Sinhgad Institute of Technology, Lonavala, Pune, Maharashtra. It is technically sponsored by IEEE Bombay Section and IETE, Pune local center, it is supported by IEEE SITSB & IETEISF, SIT Lonavala. The organizing committee of the **TECHNICOKNOCKDOWN-2023** is quite unanimous in their determination to make the event highly successful. Department of E&TC, SIT Lonavala always aims to provide the platform for “Willing to Work” professionals and researchers.

The tracks of TKD-23 are grouped broadly according to the theme

1. Internet of Things (IoT)
2. Artificial Intelligence and Machine Learning
3. Cyber Security
4. Communication Network
5. Media and Signal Processing
6. Green ICT
7. Advanced Smart Grids and Power Systems
8. Robotics and Automation
9. Others

TKD-23 received more than 97 papers out which only 37 were selected for the oral presentation after peer review. Also Skilled Session chairs are invited to evaluate the papers during presentations. Conference is imparting knowledge to more than 400 student participants to improve their skill sets.

I am quite pleased to mention that this event is successful in true spirit. This is only because of hard work, cooperation and dedication of all the coordinators as well as the participants, reviewers and faculties of the department. At the last, but not the least, I am thankful to Management of STES, Pune and Dr M. S. Gaikwad, Director STES Campus Lonavala, Principle SIT Lonavala & Organizing chairman TKD-23 for unstinting support to work as the convener of TKD-23.

**Values are More Important than Valuables**

A handwritten signature in blue ink, reading 'Dnyaneshwar S. Mantri'.

Dr. Dnyaneshwar S. Mantri  
Convener TKD-23



## Faculty Advisor IETE Student's Chapter



It gives me immense pleasure to present proceedings of the "IEEE TECHNICOKNOCKDOWN-2023 (TKD-23)" National level student conference on Green Technology, Technically Sponsored by IEEE Bombay section and IETE ,Pune Center supported by IEEE SITSB and IETE, SIT Lonavala on May 4, 2023, organized by Dept of E&TC, Sinhgad Institute of Technology, Lonavala.

IEEE opens the door to opportunities that will help you develop your professional identity in IEEE's designated fields of interest: sciences, technology, engineering, and mathematics. I congratulate all participants for their contribution and valuable research in different tracks of IEEE TKD-23. I am enlightened to note that students of IEEE SIT student's chapter and IETE student chapter under the guidance of faculty members have taken this massive task as a challenge and I am confident that they will meet to the expectations of participants.

We are infinitely indebted to all the esteemed members of the Advisory Committees, reviewer team, for their invaluable advice and guidance in conception and organization of the conference. I gratefully acknowledge the full support and cooperation I received from all the organizing members along with our student coordinators, without their cooperation and help, this dream could not have been realized at all.

I am thankful to Dr. M. S. Gaikwad, Organizing chairman & Principal, Dr. D.D. Chaudhary, Vice-Principal, & HOD, Dept. of E&TC, Dr. D. S. Mantri, Convener for Full support to work as the convener of this event.

With Most Respectful Regards

A handwritten signature in blue ink, appearing to read 'Prashant Dike', is placed above the printed name.

**Mr. Prashant Dike**

Branch Counsellor IEIE ISF SIT Lonavala



## Co-ordinator's Determination



It gives me immense pleasure that Department of Electronics and Telecommunication Engineering, Sinhgad Institute of Technology, Lonavala has taken up a great challenge of addressing the multidisciplinary aspect of learning and research through A National Level Student Conference IEEE TECHNICOKNOCKDOWN-2023 (TKD-23), technically sponsored by IEEE Bombay section and IETE, Pune Center, supported by IEEE SITSB and IETE, SIT Lonavala. The theme of the conference is not only challenging but also relevant to the present scenario in many disciplines as is evident from the range of papers which have been contributed by the students, research scholars and academicians. I hope that this volume which has been brought out by our team will be of great academic value for scholars and common readers.

A handwritten signature in blue ink, appearing to read 'Pallavi S. Mhetre'.

**Ms. Pallavi S. Mhetre**

Co-ordinator TKD-23

## Co-ordinator's Determination



It gives me an immense pleasure to welcome you all at a National level TPP “TECHNICOKNOCKDOWN-2023” organised by Dept. of E&TC SIT Lonavala. The event has brought to its success by both IETE & IEEE students chapter. The objective of IETE student's chapter is to segregate the technical knowledge and ideas to give a platform to students, researchers & developers through “TECHNICOKNOCKDOWN-2023”.

I am very much Thankful to all staff & student co-ordinators for their kind support throughout the event. At last but not least I am very much thankful to all the participants and wish you all the best for future

A handwritten signature in blue ink, appearing to read 'Manoj K. Bhosale'.

**Mr. Manoj K. Bhosale**

Co-ordinator TKD-23



## Message from Chairperson, IEEE Bombay Section



Anand S. Gharpure,

Telecommunication Market is growing exponentially to serve the ever growing demand. The research community is making efforts towards unification of communication, networks & computing in one single system. This culmination & evolution of traditional telecommunication system is redefined as Next Generation Network, NGN. A wide array of applications from Voice/Data Services, VPNs, E-commerce, Data Augmentation and 3D Imaging can be processed through NGN. The next generation network will have to build in parallel to the current architecture.

In this context, it is exciting to know that the IEEE Student Branch of the Sinhgad Institute of Technology (SIT), Lonavala, in association with IEEE Bombay Section and IETE is organizing the third National Level Student Conference as “**Technicoknockdown-23 (IEEE TKD-23) with “Next Generation Network”**” as the theme on May 05 –May 06 2023.

It will be noteworthy to witness the industrial and academia exploring this technology in this upcoming Conference. We, IEEE Bombay Section urge each and every one to seize this opportunity by attending in large and network widely. Lastly, We, IEEE Bombay section, would like to wish a conference a grand success.

Anand S Gharpure,  
Chair,  
IEEE Bombay Section



## Message from, IETE Pune Center



Dr.Virendra. V. Shete

It gives me immense pleasure to know that Department of E&TC Engg. Sinhgad institute of Technology, Lonvala is organizing National level student conference “IEEE TECHNICOKNOCKDOWN-2023 (TKD-23)”. Technically sponsored by IETE, Pune center. I welcome all dignitaries & Participants, for the conference, Research articles are invited from the scholars on various tracks including Internet of things, (IoT) AI & ML, cyber security, Communication network, Media & signal processing, Green ICT, Advanced smart grids & Power systems & Robotics & automation.

I am hopeful that the conference will draw inspiring participation of Eminent scientists, Technocrats, Academicians & Industrialists will generate useful knowledge.

On this occasion on behalf of IETE, Pune center, I extend my warm greetings & best wishes for a successful organization of National conference & also for publishing a souvenir-cum proceedings of the conference.

Dr.V. V. Shete  
Chairman, IETE, Pune Centre



## SAC Chair, IEEE Bombay Section,



Prof. Dattatray S. Sawant

I am pleased to welcome everyone to the IEEE TECHNICOKNOCKDOWN 2023(TKD-23) Student National Conference, organized by Sinhgad Technical Education Society's SINHGAD INSTITUTE OF TECHNOLOGY ( SIT) Lonavala Pune in association with IEEE Bombay section and IETE, Pune Center, supported by IEEE SITSB and IETE ISF SIT, Lonavala. The theme of this conference is Frontiers of Technologies: Next Generation Networks.

TKD-23 provides a platform to students within India to exchange thoughts about technology research in Artificial Intelligence and Machine Learning, Data Science and Analytics, Communication and Information security, Robotics, and Automation etc. These tracks in the conference have attracted a large volume of submissions from various states across India.

I take this opportunity to thank all the authors who submitted their papers and congratulate the authors of the selected papers that made it through the strict review process and have been selected for presentation.

I believe that the young researchers, who form a large percentage of the authors, would make the maximum use of this opportunity to engage with their peers and seniors to take a step towards leveraging technology for societal contribution and personal growth.

. .

Prof. Dattatray S. Sawant  
SAC Chair, IEEE Bombay Section



## Keynote Speaker Details



Anand Suhas Gharpure  
Chair, IEEE Bombay Section

Anand Suhas Gharpure did his BE in Electronics from University of Pune. He has also completed the Post Diploma in Medical Electronics and Diploma in Industrial Electronics. He is Chartered Engineer & Fellow Member of Institution of Engineers India, Senior Member of IEEE USA, Member of Aeronautical Society of India & Fellow member of IETE India. He is an awardee of IETE-Flt Lt Tanmany Dandass Memorial Award 2015 for Design & Development of Avionics for MiG-27 Vibration Measurement. He is an Executive Committee Member and Webmaster of IEEE Bombay Section (Maharashtra and Goa except Pune City) for more than 10 years. He has also been Past Chair of IEEE Bombay Section Young Professional Affinity Group in 2015-16. He is External Examiner for University of Pune. He has been invited for Expert Talks at various Institutes including VJTI, NIT Raipur, BITS-Goa and delivered more than 75 talks on Embedded Systems & Entrepreneurship. Professionally, he runs the Avionics Development company (M/s. Sonic Multitech Pvt Ltd) in Nashik which caters to Indian Air Force, Indian Navy, Indian Army along with DPSU's like HAL. The Company has been approved as Design House from CEMILAC and Approved by Dept of Scientific & Industrial Research (DSIR) as In-House R&D Center. He also manages the Electronics Testing Laboratory (M/s. Herrmann Research Products & Laboratories Pvt Ltd) in Nashik which is accredited by NABL as per ISO17025:2005 & approved by DGAQA which carries out the Environmental Testing for Electronics products.

## Details of Session Chairs



Dr. Nandkumar P. Kulkarni received Bachelor of Engineering (B.E.) degree from Walchand College of Engineering, Sangli, Maharashtra, (India) in 1996. He completed a Master of Technology (M. Tech) degree with computer specialization from COEP, Pune (India) in 2007 and Ph.D. from Aarhus University, Denmark in 2019. He has been with Electronica, Pune from 1996 -2000. He worked on retrofits, CNC machines and was also responsible for PLC programming. In 2000, he received the Diploma in Advanced Computing (C-DAC) degree from MET's IIT, Mumbai. In 2002, He became Microsoft Certified Solution Developer (MCSD). He worked as a software developer and system analyst in CITIL, Pune and INTREX India, Mumbai respectively. He has 24 years of experience both in industry and academia. From 2002 onwards he is working as a faculty in Savitribai Phule Pune University, Pune. Currently is working with MID ADT University as a faculty in IT Department. His area of research is in WSN, VANET, and Cloud Computing. He has published papers in 18 International Journals, 15 International IEEE conferences, 03 National Conferences



Dr. Ravindra N Duche is graduated in Electronics Engineering from KES Engineering College, Pen from Mumbai University in 1994 and received Masters from Shivaji University in 2005 .He has awarded PhD in Electronics Engineering from VJTI, Mumbai University in 2014. He has teaching experience of 28 years. From 1995 to 2015 he was working as a Lecturer , Asssistant Professor and Associate Professor in different institutes [ KESEC, Pen, DMCoE, Airoli , YTIET, Karjat, VIT, Wadala and PHCET, Rasayani]

From 2015 he is associated with Lokmanya Tilak College of Engineering, Koparkhairane, Navi Mumbai and presently he is working as Professor and Head of Department of Electronics and Telecommunication Engineering. He is Life Member of ISTE and ACEE. He has published one Patent, one copyright, 07 Journal papers in indexed and reputed Journals (IEEE, IET, etc.) and 21 papers in Conferences. He is reviewer of international journals (IEEE, Springer, IET, EURASIP, IJETI, etc.) and conferences organized by IEEE. He worked as Member BoS in EXTC of Mumbai University and EEE of Amity University. He is Winner of AVISHKAR Competition in 2014 and received Academic Excellence Award in 2022 in HoD Category at Regional Level by IEI-FCRIT, Mumbai. His research interests are in Wireless Sensor Networks, VLSI and Neural Network. He is Approved PhD Supervisor in Mumbai University. One student has successfully completed PhD under him in 2019.



**Dr. Ramesh Sahadu Pawase** is graduated in Electronics Engineering from Amrutvahini College of Engineering, Sangamner (MS) India in 2004 and completed M.Tech in E&TC from Dr. Babasaheb Ambedkar Technological University, Lonere in 2009. He is awarded with Doctor of Philosophy from Savitribai Phule Pune University in 2019. He was involved in funded research project and Doctor of Philosophy work in the area of Application Specific Integrated Circuit development for MEMS Sensors. He is actively contributing in the field of Engineering

Education and Research with teaching experience of 16 years at Amrutvahini College of Engineering, Sangamner, Permanently affiliated, NAAC 'A' grade and three times accredited institute.

He published and presented more than 32 papers in SCI and Scopus indexed, reputed International journals and IEEE International conferences. He is reviewer of International Journals and contributed as TPC member for International Conferences. He is awarded with 'Engineering Achievement Award' by Institution of Engineers, India (IEI), Ahmednagar Centre on Engineer's Day 2020. He is active member of professional bodies like IEI, ISTE, IAENG, and IACSIT. He had worked for five years as National Social Scheme-University Section level Coordinator and Institute-Program Officer and actively coordinated Social activities.



Mr. Abdul Hameed Ansari, Work experience. 24 years B.E (E&TC) in 1997. M.E. (Digital Electronics) in 2005 from Sant Gadge Baba Amravati University Amravati. Pursuing PhD from Sant Gadge Baba Amravati University Amravati as well. Worked for Poonitronics (India) Pvt. Ltd, Pune as Design Engineer, Worked in Rajaram Shinde College of Engineering, Pedhambe for eight years under Mumbai University,

Working as an Associate Professor in Pravara Rural Engineering College, Loni since 2006, Worked in various capacities like, Convener for the Pravara Institute of Skill Development, Loni., Minority Scholarship Cell Officer, working as the principal investigator for SC/ST skill and Personality Development Cell, Convener for International Conference and National Conferences at PREC, Loni., Skill Development Coordinator under NSDC., Principle investigator for various AICTE based funded schemes, He has published more than 23 papers in national and international conferences.



Mrs. Sheetal K. More  
Session Incharge

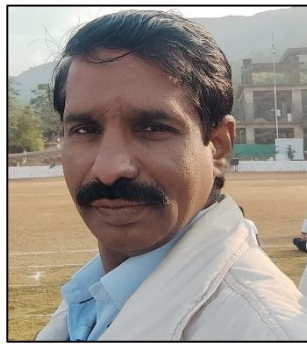

Mr . Vikas D. Raskar  
Session Incharge

## Our Chief Patrons

### Sinhgad technical Education Society, Pune



**Prof. M. N. Navale**  
Founder President,  
Sinhgad Institutes, Pune



**Dr.(Mrs) Sunand M . Navale**  
Founder Secretary,  
Sinhgad Institutes, Pune



**Rohit M. Navale**  
Navale Vice President (HR),  
Sinhgad Institutes, Pune



**Dr.(Mrs) Sunand M .**  
Vice President (Admin)  
Sinhgad Institutes, Pune



# Advisory Body and Organizing Committee

## Advisory Committee

Mr. Anand Gharpure, Chair, IEEE Bombay Section  
 Dr. Satyanarayana Bheesette, Immediate past Chair, IEEE Bombay Section  
 Mr. Kiran Talele, Treasurer, IEEE Bombay Section  
 Dr. Saurabh Mehta, Secretary, IEEE Bombay Section  
 Mr. Dattaraya Sawant, Member, Chair SAC, IEEE Bombay Section  
 Dr. Sarika Chouhan, Immediate past, Member, Chair SAC, IEEE Bombay Section  
 Dr. V. V. Shete, Chairman IETE, Pune local center  
 Dr. R. D. Kharadkar, Immediate Past, Chairman IETE, Pune Local Center  
 Dr. D. G. Bhalke, Secretary, IETE, Pune Center  
 Dr. Sunil Somai, Treasurer, IETE Pune, Local Center  
 Mr. S. M. Gaikwad HOD, Mech Dept., SIT Lonavala  
 Dr. S. D. Babar HOD, Comp. Dept., SIT Lonavala  
 Mr. A. A. Datey HOD, Elect. Dept., SIT Lonavala  
 Dr. P. S. Patil HOD, FE Dept., SIT Lonavala  
 Dr. R.V. Babar, HOD, IT Dept., SIT Lonavala

## Organizing Chairman

Dr. M.S. Gaikwad, Director, STES Campus Lonavala  
 Principal, Sinhgad Institute of Technology Lonavala  
 Dr. D.D. Chaudhary, Vice-principal & HOD, Dept. of E&TC, SIT Lonavala

## Convener

Dr. D. S. Mantri, Professor, Dept. of E&TC, SIT Lonavala  
 Mr. P. R. Dike, Asst. Prof., Dept. of E&TC, SIT Lonavala

## Co-ordinator

Ms. P. S. Mhetre, Asst. Prof., Dept. of E&TC, SIT, Lonavala  
 Mr. M. K. Bhosale Asst. Prof., Dept. of E&TC, SIT Lonavala

## Session Coordinator

Mr. M. K. Bhosale, Asst. Prof., Dept. of E&TC, SIT Lonavala  
 Mr. V.D. Raskar, Dept. of E&TC, SIT Lonavala

## Publication (Editorial) Committee

Mr. V. M. Chavan, Asst. Prof., Dept. of E&TC, SIT Lonavala  
 Mr. Aniket Lamkhade, Student Chairman, IEEE SITSB  
 Mr. Lokesh Singh, Student Chairman, IETEISF

## Technical Support

Ms. R. D. Mantri, Dept. of Mechanical Engineering, SIT Lonavala  
 Ms. D. S. Mali, Dept. of E&TC, SIT Lonavala  
 Ms. S. B. Pandit, Dept. of E&TC, SIT Lonavala

## Organizing committee

Dr. S. B. Gholap	Devashish Lahariya
Ms. S.S. Patil	Rajeshri More
Mr. A. A. Labade	Sanskritii Gaikwad
Ms. V.G. Rajeshwarkar	Aryan Kotmire
Ms. S.K. More	Aryan Shrivastav
Mr. S.A. Bhad	Isha Soge
Mr. M.S. Raut	Bhaves Kshirsagar
Ms. C. A. Mhetre	



## List of Reviewers

1. Dr. Ramesh S. Pawase, Amrutvahini COE, Sangamner
2. Dr. Shyam M. Kulkarni, Professor, JSPM Narhe
3. Dr. Sarita D. Deshpande, Modern COE Pune
4. Ms. Vaishali S. Baste, SIT Lonavala
5. Dr. Nandkumar P. Kulkarni, SKNCOE Pune
6. Dr. Jyoti Gangane, Vishwaniketan
7. Dr. Sharad Gholap, SIT Lonavala
8. Dr. Milind Tadwalkar, JSCOE Pune
9. Dr. Pranav Pawar, BITS Pillani, Duabi
10. Prof. Abdul H. Ansari, PREC Loni
11. Mr. Prashant Dike, SIT Lonavala
12. Mr. Manoj K. Bhosale, SIT Lonavala
13. Prof. Giridhar P. Jain, WIT, Solapur
14. Dr. Ravindra N. Duche, LTE Mumbai
15. Mr. Nilesh Lakade, K. J. Somaiya Mumbai
16. Dr. Dnyaneshwar.S. Mantri, SIT Lonavala
17. Dr. Sachin D. Babar, SIT Lonavala
18. Mr. Vikram M. Chavan , SIT Lonavala
19. Mr. Rajesh Pansare, K. J. Somaiya college of Engineering, Vidyavihar Mumbai
20. Mr. Vinayak Gaikwad, SIT lonavala
21. Mr. Nishant N. Pachpor,
22. M. Sachin Jadhav, PCCOE Pune
23. Mr. Virendta Bagade, PICTE, Pune
24. Dr. Shubhangi Patil, JJMCOE, Jaisighpur
25. Dr. Balasaheb B . Patil, PVPIT Budgaon, Sangali
26. Ms. Seema Patil, Asokrao Mane College Watar
27. Mr. Shripad S Velling, Shindhudurga Subcampus, Mumbai
28. Savita Itkalkar, Bharti Vidyapeeth Pune,
29. Dr. Kaustubh M. Gaikwad, SAE, Kondhwa
30. Mr. Atul Ingole, SAE Kondhwa
31. Ms. Rajashree Bhokare, DIT, Pimpari
32. Mr. M. R. Umbarkar, Govt. Poly Jalgaon
33. Mr. Mahesh C. Patil Shah Anchor Kutchhi, Engg. Mumbai
34. Dr. K. V. Ajetroa. K J Somaiya , Mumbai
35. Ms. Manju Pawar, MIT, Aurangabad
36. Ms. Rupali Shishupal, SIT Lonavala
37. Ms. Vaishali N. Dhavas, SIT lonavala
38. Ms. Manisha Galphade, MIT ADT, Pune,
39. Dr. Rohita Patil, SCOE, Pune
40. Mr. Santosh L. Mhetre , SIT Lonavala



Sinhgad Technical Education Society's  
**SINHGAD INSTITUTE OF TECHNOLOGY, LONAVALA**

Department of Electronics and Telecommunication Engineering

**National level Student Conference IEEE TECHNICOKNOCKDOWN-2023 (TKD-23)**

Technically Sponsored by IEEE Bombay section and IETE, Pune center supported by IEEE SITSB and IETE SIT, Lonavala



**Schedule - Session I,II,III,IV**

**Thursday, May 04, 2023**



Inauguration : 09.45 am to 10.15 am		<a href="https://meet.google.com/rms-faut-fhq">https://meet.google.com/rms-faut-fhq</a>			
Keynote Speaker: 10.30 am to 11.15 am		Mr.Anand Gharpure, Chair, IEEE Bombay Section,"Next Generation Network: Introduction ,Challanges & opportunities"			
<b>Artificial Intelligence and Machine Learning -1</b>			<b>Session-I</b>		
<b>Session-I Link</b>		<a href="https://meet.google.com/iwr-rkxe-rxa">https://meet.google.com/iwr-rkxe-rxa</a>			
SN	Time	Paper ID	Title of Paper	Author Name	Coordinator/Chair
1	11.30 am to 1.30 pm	AIML-01	Object Detecting And Recognizing Robo Using Raspberry Pi And Machine Learning	Singh Lucky Santosh	Student Coordinator
2		AIML-02	Docking Algorithms For Autonomous Landing Uav: A Roadmap	Pratik Gangapurwala	MS. Shrutika Girhee 7499395568
3		AIML-05	A Comparative Study Of Different Algorithms For Fake News Detection Using Machine Learning	Ishita Thakur	Session Coordinator
4		AIML-06	Soil Doctor : The Farming Solution	Dr.A.B.Gavali	Mrs. Shital More 9923049992
5		AIML-08	Intelligent Cancer Prediction And Analysis System Based On Machine Learning Techniques	Prathamesh Birajdar	Session Chair
6		AIML-10	Comparative Study For Fish-Feeding And Sustainable Growth In Aquaculture	Kanika Singh	Prof. A.H. Ansari
7		AIML-12	Natural Gas Price Prediction Using Random Forest Algorithm	Shruti Sanjay Anasane	
<b>Artificial Intelligence and Machine Learning -2</b>			<b>Session-II</b>		
<b>Session-II Link</b>		<a href="https://meet.google.com/gik-uccf-vex">https://meet.google.com/gik-uccf-vex</a>			
SN	Time	Paper ID	Title of Paper	Author Name	Coordinator/Chair
1	11.30 am to 1.30 pm	AIML-14	Chrome Extension For Detection And Prevention Of Phishing Websites And Related Attacks By Using Machine Learning And Deep Learning	Vinayak Jalan	Student Coordinator
2		AIML-16	Learning Algorithms In Data Science	Aarti Verma	Mr.Manas Patil 8857841227
3		AIML-17	Revolutionizing Indian Agriculture Through Machine Learning Based Crop Recommendation System	Mohd Faizaanuddin	Session Coordinator
4		AIML-18	Role Of Nature Inspired Algorithms In Business Analytics	Mahak Garg	Mrs. Pallavi Mhetre 9404249846
5		AIML-19	Real Time Classification And Localization Of Eye Diseases Using Artificial Intelligence	Ms. Anupreeta Arvind Bidarkote	Session Chair
6		AIML-20	Face Recognition Based Smart Attendance System	Revati Pisal	Dr. Nandkumar P. Kulkarni
<b>Cyber security +IoT</b>			<b>Session-III</b>		
<b>Session-III Link</b>		<a href="https://meet.google.com/rms-faut-fhq">https://meet.google.com/rms-faut-fhq</a>			
SN	Time	Paper ID	Title of Paper	Author Name	Coordinator/Chair
1	11.30 am to 1.30 pm	CS-02	Artificial Intelligence For Cyber Security	Aniket Dilip Karse	Student Coordinator
2		CS-03	Cybercrime And Law Enforcement: A Review Of International Approaches	Utkarsh Varshney	Vaibhav Jaiswal 8320247541
3		CS-04	Social Engineering Attack - Scopes, Types And Its Working	Tanisha Dixit	Session Coordinator
4		IOT-01	Live Inventory Monitoring For Contactless Smart Vending Machine	Muskan Singh	Mr. Vikas Raskar 9421004998
5		IOT-04	IoT Based Smart Wireless Noticeboard	Mugdha Arvind Tamhan	Session Chair
6		IOT-05	Redefining Attendance Systems With Facial Recognition	Rishikesh Sanjay Kumar	Dr. Ranvindra N.Duche
7		RA-02	Wireless Technology Based Fault Diagnosis In Industrial Water Level Control With Temperature Data Remote Monitoring And Recording System Using Plc And Scada	KHALED HASHALA	
<b>Others (OT)</b>			<b>Session-IV</b>		
<b>Session-IV Link</b>		<a href="https://meet.google.com/neq-omkk-gon">https://meet.google.com/neq-omkk-gon</a>			
SN	Time	Paper ID	Title of Paper	Author Name	Coordinator/Chair
1	11.30 am to 1.30 pm	OT-03	Hardware (Sensor) For E-Bicycle	Dr. A. V. Patil	Student Coordinator
2		OT-07	Wireless Electric Vehicle Charging System Using Solar	Shivraj Kete	Lokesh Singh -8320247541
3		OT-08	Comparative Analysis Of Model Order Reduction Techniques For Higher Order System	YUSEF HUSSEIN MOHAMMED	Session Coordinator
4		OT-09	Identification Of Duplicate Bugs In Bug Triaging System	Prajwal Pandey	Mr.Manoj Bhosale 9850581234
5		OT-12	Arduino Augmented Reality Headsets	Namrata Chande	Session Chair
6		OT-16	Solar Powered Operated Water Trash Collector	Ganesh khabale.	Dr. Ramesh S. Pawase

*Dr. D. S. Mantri*

Dr. D. S. Mantri  
Convener  
TKD-23



*Dr. D. D. Chaudhary*

Dr. D. D. Chaudhary  
Organizing Chair  
TKD-23

*Dr. M.S. Gaikwad*

Dr. M.S. Gaikwad  
Organizing Chair  
TKD-23

National Level Student Conference

**“IEEE TECHNICOKNOCKDOWN-2023 (TKD-23)”**

Organized by Department of E&TC,  
Sinhgad Institute of Technology, Lonavala

(Online Mode)



**INDEX**

SR. NO.	PAPER ID	TITLE	AUTHORS	PAGE NO:
1	AIML-01	Object Detecting And Recognizing Robo Using Raspberry Pi And Machine Learning	Singh Lucky Santosh	1
2	AIML-02	Docking Algorithms For Autonomous Landing Uav: A Roadmap	Pratik Gangapurwala	6
3	AIML-05	A Comparative Study Of Different Algorithms For Fake News Detection Using Machine Learning	Ishita Thakur	10
4	AIML-06	Soil Doctor : The Farming Solution	Dr.A.B.Gavali	16
5	AIML-08	Intelligent Cancer Prediction And Analysis System Based On Machine Learning Techniques	Prathamesh Birajdar	20
6	AIML-10	Comparative Study For Fish-Feeding And Sustainable Growth In Aquaculture	Kanika Singh	25
7	AIML-12	Natural Gas Price Prediction Using Random Forest Algorithm	Shruti Sanjay Anasane	29
8	AIML-14	Chrome Extension For Detection And Prevention Of Phishing Websites And Related Attacks By Using Machine Learning And Deep Learning	VinayakJalan	33
9	AIML-16	Learning Algorithms In Data Science	Aarti Verma	38
10	AIML-17	Revolutionizing Indian Agriculture Through Machine Learning Based Crop Recommendation System	Mohd Faizaanuddin	43
11	AIML-18	Role Of Nature Inspired Algorithms In Business Analytics	Mahak Garg	48
12	AIML-19	Real Time Classification And Localization Of Eye Diseases Using Artificial Intelligence	Ms.Anupreeta Arvind Bidarkote	53
13	AIML-20	Face Recognition Based Smart Attendance System	Revati Pisal	57
14	IOT-01	Live Inventory Monitoring For Contactless Smart Vending Machine	Muskan Singh	62
15	IOT-04	Iot Based Smart Wireless Noticeboard	Mugdha Arvind Tamhan	66
16	IOT-05	Redefining Attendance Systems With Facial Recognition	Rishikesh Sanjay Kumar	71
17	CS-02	Artificial Intelligence For Cyber Security	Aniket Dilip Karse	76



18	CS-03	Cybercrime And Law Enforcement: A Review Of International Approaches	Utkarsh Varshney	81
19	CS-04	Social Engineering Attack - Scopes, Types And Its Working	Tanisha Dixit	86
20	RA-02	Wireless Technology Based Fault Diagnosis In Industrial Water Level Control With Temperature Data Remote Monitoring And Recording System Using Plc And Scada	Khaled Hashala	92
21	OT-03	Hardware (Sensor) For E-Bicycle	Dr. A. V. Patil	96
22	OT-07	Wireless Electric Vehicle Charging System Using Solar	Shivraj Kete	102
23	OT-08	Comparative Analysis Of Model Order Reduction Techniques For Higher Order System	Yousef Hussein Mohammed al-Qardai	107
24	OT-09	Identification Of Duplicate Bugs In Bug Triaging System	Prajjwal Pandey	112
25	OT-12	Arduino Augmented Reality Headsets	Namrata Chande	117
26	OT-16	Solar Powered Operated Water Trash Collector	Ganesh khabale.	122



**Dr. D. S. Mantri**  
Convener TKD-23

**Dr. D. D. Chaudhary**  
HOD, Dept. of E&TC

**Dr. M. S. Gaikwad**  
Principal, SIT Lonavala

# Object Detecting and Recognizing Robo Using Raspberry Pi and Machine Learning

Mayur Raut<sup>1</sup>, Lucky Singh<sup>2</sup>, Aman Chaudhari<sup>3</sup>

*TPO, Department of Electronics and Technology, India<sup>1</sup>*

*Students, Department of Electronics and Technology, India<sup>2,3</sup>*

Sinhgad Institute of Technology, Lonavala, Maharashtra, India

mraut.sit@sinhgad.edu<sup>1</sup>

lucky.sit.entc@gmail.com<sup>2</sup>

amanchaudhari.sit.entc@gmail.com<sup>3</sup>

**Abstract--** The research involved suggests constructing an autonomous vehicle that can recognize and acknowledge objects using a Raspberry Pi and machine learning algorithms. The autonomous vehicle can move about on its own while employing computer vision algorithms to recognize various objects.

The system accomplishes object identification and recognition using a camera module and the TensorFlow machine learning library. A Python script that comprehends the camera images in real-time and delivers instructions to the robot's motors to change its movement controls the robot. A pre-trained convolutional neural network (CNN) can be taught via transfer learning on a unique dataset of objects in the proposed system. Real-time object recognition is done using the CNN [5]. The robot's performance is assessed by testing its capacity to find and identify various things in various settings. The outcomes demonstrate that the robot can recognize things with accuracy, making it appropriate for use in a variety of applications, including monitoring, security, and surveillance.

**Keywords--** Object Detection and Recognition, Robotics, M&L Machine Learning Algorithms.

## I. INTRODUCTION

According to an assessment released by MarketsandMarkets, the market for object detection and recognition is anticipated to increase from USD 12.5 billion in 2020 to USD 32.9 billion by 2025, throughout the anticipated time span, at a CAGR of 21.1% [7]. The growth of this sector is being fueled by the need for sophisticated video surveillance systems, advancements in deep learning algorithms, and growing use of internet of things (IoT) devices. However, object identification and recognition are an indispensable problem in computer vision and robotics. It involves finding and comprehending objects in an image or video sequence and has a variety of applications, including monitoring,

security, and surveillance [2]. Numerous techniques, such as traditional computer vision methods and machine learning algorithms, have emerged over time to handle these jobs. Owing to the recent advancement of potent and reasonably priced single-board computers like the Raspberry Pi, it is now possible to design intelligent robots that can perform difficult tasks like item the identification and recognition [1].

## II. MOTIVATION

The ultimate objective of this research study is to use the Raspberry Pi and machine learning techniques to offer a low-cost and effective solution for object detection and recognition. Important tasks in computer vision include object detection and recognition, which have a wide range of applications in fields including robotics, security, surveillance, and monitoring [2,4]. However, the majority of the currently available object detection and recognition solutions rely on pricey hardware and software, rendering them out of reach for many. This issue might be resolved by using the Raspberry Pi, a reasonably priced and adaptable single-board computer that can be utilized to create intelligent systems when combined with potent machine learning frameworks like TensorFlow [1]. As a result, the goal of this research study is to create a robot that can identify and recognize objects using a Raspberry Pi and machine learning algorithms.

## III. PROBLEM STATEMENT

The need for an effective and affordable solution for object detection and recognition in practical applications, such as security surveillance and industrial automation, is the issue this research article attempts to solve. Because of their high hardware and software costs, many enterprises and organizations with limited funding are unable to use the existing solutions for object detection and recognition. Manual item recognition and detection can also be labor-intensive, subject to

human mistake, and call for a sizable workforce, all of which can raise operational costs.

This research article suggests creating an item detecting and recognizing robot utilizing a Raspberry Pi and machine learning methods to get over these problems. The suggested approach can assist organizations in automating their item detection and recognition processes, which will enhance operational effectiveness, lower costs, and boost accuracy. The system may also be quickly modified and scaled to meet the unique requirements of diverse applications, making it a flexible and adaptable solution for a variety of disciplines.

IV. OBJECTIVES

- To use Raspberry Pi and machine learning techniques to build and create an inexpensive and effective robot that can detect and recognize objects.
- To use transfer learning to train a pre-trained Convolutional Neural Network (CNN) on a unique dataset of objects for effective object recognition.
- To put into practice the created system's ability to move about on its own and instantly recognize diverse objects.
- To compare & evaluate the performance of the developed system with that of existing systems for object detection and recognition in terms of accuracy, cost, and convenience of use.

V. METHODOLOGY

The following is a methodology that may be used for a research paper on Object Detecting and Recognizing Robo Using Raspberry Pi and Machine Learning Using YOLO algorithm and TensorFlow:

- **Hardware and Software Setup:** The first stage is to construct the robot's hardware, which includes the Raspberry Pi, the camera module, the motors, and any other required accessories. The software setup then entails setting the Raspberry Pi and installing the necessary libraries, such as OpenCV, TensorFlow, and YOLO.
- **Data Gathering and Preparation:** A dataset of objects must be gathered, labelled, and preprocessed in order to train the YOLO algorithm. The dataset can be built using a unique dataset of items or by gathering data from numerous sources.
- **Training and Fine-tuning:** The YOLO algorithm is taught using transfer learning in TensorFlow on a bespoke dataset of objects. To maximize the model's accuracy and speed, fine-tuning can be used.
- **Integration with Robot:** The YOLO method is integrated with the robot using OpenCV for real-time object detection and recognition after it has been trained and optimized. The robot may then move independently in order to find and identify objects.
- **Evaluation and Comparison:** The accuracy, precision, and recall of the designed system's performance are assessed. The system's performance is contrasted with those of other object detection and recognition systems already in use, including those that make use of different algorithms or hardware setups.

VI. LITERATURE REVIEW

Sr No.	TITLE	AUTHOR	METHODOLOGY	Gaps
1.	Object Detection Using Image Processing	Fares Jalled	The primary objective of the article is the creation of an OpenCV-Python method for Haar Cascade-based object and face detection. Currently, UAVs are used to locate and strike ground targets that have been infiltrated. The main drawback of these UAVs is that occasionally they fail to recognize an object concisely, which results in the object colliding with the UAV. This effort aims to stop harm and collisions caused by inadvertent UAV operations. The Voila-Jones method is also used by UAV surveillance to track and find people. The cascade object detector function and vision are utilized by this approach [6].	Requires modification to improve the speed of the controller.

2	Raspberry Pi Based Object Detection and Drawing	Talha Bayrak, VedatMarttin, UğurYüzgeç	<p>In this study, a hardware-based drawing machine is combined with the TensorFlow, OpenCV, and BrachioGraph libraries in order to recognize and draw objects. They used image processing and object sketching in the Raspberry Pi environment to accomplish object recognition. The drawing device's hardware included a Raspberry Pi 3 processor, a Picamera camera, and 12g Emax servo motors. It has a quad-core ARMv8 processor with a 1.2 GHz clock speed. The object recognition method was carried out in the software portion using TensorFlow and OpenCV frameworks. Using the BrachioGraph library, the altered images were converted to vector format, and servo motor drawing tests were run. It was discovered that servo motor type and calibration adjustments were important[1].</p>	<p>One of the limitations observed that the vectorial design depends on the distance between the pen and ground thus at different levels we can get different images or designs than expected.</p>
3	Dark Assistant: A Raspberry Pi Based System for Object detection and Recognition for Blind	Praharsh Verma, Yogesh Sondulkar, Sameer Zaki Diwan, Bikas Majumdar, Swati Saxena	<p>The World Health Organization (WHO) estimates that 285 million people worldwide are blind or visually impaired. Out of this group, there are 39 million blind people on the planet. The biggest problem faced by blind people daily and one of the most significant—is hitting obstacles. People who are blind or visually handicapped are at risk because they lack the information needed to navigate because so much of navigation relies on sight. Travelers with visual impairments might now receive more assistance thanks to recent advancements in integrated technology. In this situation, we recommend a program called Dark Assistant, whose objective is to provide blind individuals with a simple interface via which they may navigate in unfamiliar environments, both inside and outside[2].</p>	<p>The detection period is increased because of the comparison with each frame</p>

4	A Study on Object Detection	S.Manjula, Dr.K.Lakshmi	<p>Video cameras are frequently used in daily life to keep an eye on campuses. Most of these surveillance techniques use personnel to monitor activity in the target area. However, using people as monitors has problems of its own. Researchers are creating automated visual surveillance technologies to get past this constraint. The first and most crucial step in visual surveillance is identifying moving objects in a video clip. The moving object of interest could be a person, an automobile, or another item. Identifying the semantic class of the moving object in the video sequence is the focus of the object detection technology. The importance of object detection in visual surveillance is discussed in this paper along with the many object detection methods that are available. Automatic visual surveillance has a wide range of uses, such as distant human identification, traffic monitoring, the detection of anomalous behavior, etc.[4].</p>	<p>The expected output of the system can change with a small variation in the background, low resolution, and illuminance variation.</p>
---	-----------------------------	----------------------------	--	--

VII. SYSTEM ARCHITECTURE

VIII. SOFTWARE REQUIREMENT

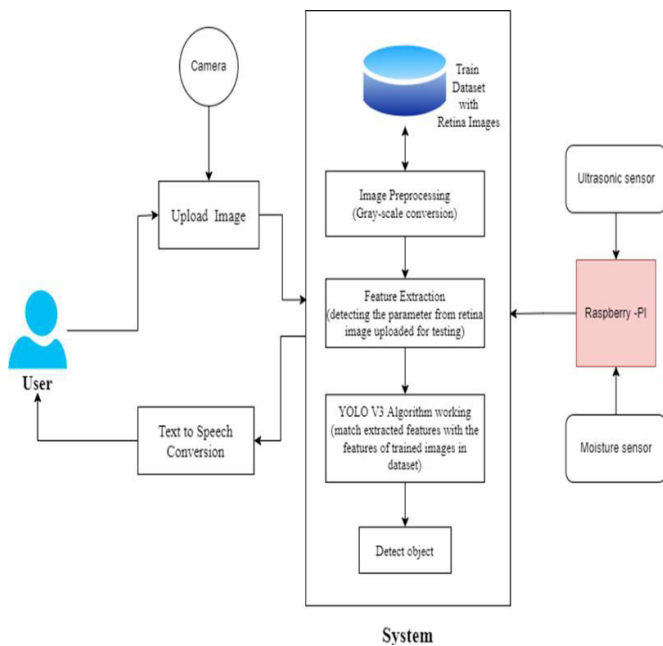

Fig. 1. System Architecture

- Python 3.7
- YOLO
- Apache web server (7.1)
- MySQL DB
- Google Assistant SDK
- RAM: 8GM
- Processor: Intel I5

IX. HARDWARE REQUIREMENT

- Raspberry PI
- Ultrasonic Sensor
- Camera.
- 9 V Battery
- Switch
- Bluetooth Module
- Speech Synthesizer
- Robot Chassis
- Arduino Motor Driver
- DC Motor

X. ALGORITHM

1. Start
2. Establishing a virtual environment
3. Gathering and labelling images taking pictures with your webcam
4. Labellmg Training: Labelling Images for Object Detection Models for TensorFlow's Object Detection
5. How to Create and Update a Label Map
6. Evaluation of OD Models (Precision and Recall) after TensorFlow Object Detection Model Training for Python
7. Object Recognition in Images
8. Displaying the last recognized object as an output in voice or image
9. Stop

#### XI. FLOW DIAGRAM

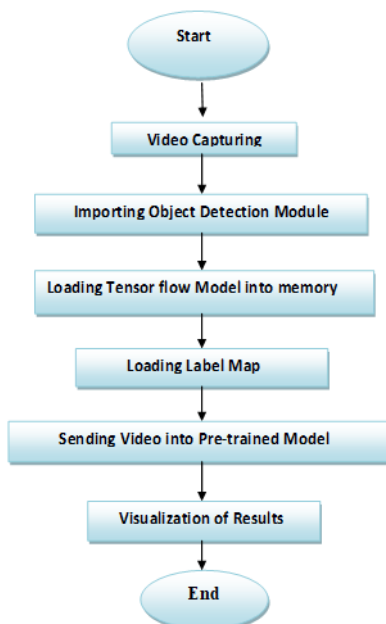

Fig. 2. Flow Diagram for Identification of object

#### XII. ADVANTAGES

- Enhanced operational effectiveness
- Cut expenses
- Higher precision
- Easily scalable and modifiable
- Versatile and adaptable

#### XIII. RESULT

The findings of the study using a robot for object detection and recognition The YOLO algorithm and TensorFlow on the Raspberry Pi are used to show how the suggested system can accurately detect and recognize a variety of objects in real-time with high precision and recall. The system was able to recognize and identify items with up to 95% accuracy in a variety of situations and lighting conditions.

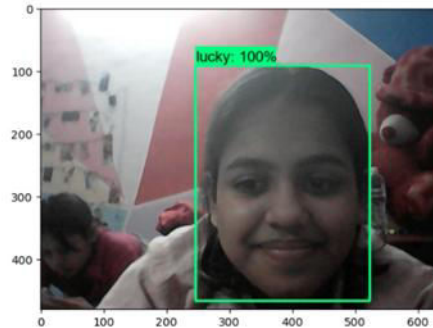

Fig. 3. Output of the system in which the object is successfully detected and recognized

#### ACKNOWLEDGEMENT

The preliminary project report on "Object Detecting and Recognizing Robo Using Raspberry Pi and Machine Learning" is presented with great delight. I would want to take this chance to express my gratitude to Prof. Mayur Raut, our college's TPO and internal advisor, for providing us with all the support and direction we required. He has been quite friendly to us, and we appreciate that. His insightful advice was incredibly beneficial.

#### REFERENCES

- [1] Talha Bayrak, VedatMarttin, UğurYüzgeç, "Raspberry Pi Based Object Detection and Drawing", Global Conference on Engineering Research, 02-05 June 2021
- [2] Prahars Verma, Yogesh Sondulkar, Sameer Zaki Diwan, Bikas Majumdar, Swati Saxena, "Dark Assistant: A Raspberry Pi Based System for Object detection and Recognition for Blind", International Journal of Innovative Research in Science, Engineering and Technology, Volume 9, Issue 4, April 2020
- [3] Esha Chokhar, Prajakta Thakare, Vaishnavi Gawande, "Smart System For Object Detection And Recognition For Visually Disabled People", International Research Journal of Modernization in Engineering Technology and Science, Volume:04/Issue:05/May-2022
- [4] S.Manjula, Dr.K.Lakshmi, "A Study On Object Detection", International Journal of Pharmacy & Technology, ISSN: 0975-766X
- [5] Rekha B. S., Athiya Mariam, Dr. G. N. Srinivasan, Supreetha A. Shetty, Volume: 07 Issue: 06 June 2020 "Literature Survey on Object Detection using YOLO", International Research Journal of Engineering and Technology (IRJET)
- [6] Fares Jalled, "Object Detection Using Image Processing", 23<sup>rd</sup> Nov 2016.
- [7] MarketandMarket, "Image Recognition Market 222404611", marketsandmarkets.com, <https://www.marketsandmarkets.com/Market-Reports/image-recognition-market-222404611.html>

# Docking Algorithms for Autonomous Landing UAV: A Roadmap

Pratik Gangapurwala, Ishani Singh, Shabda Satam

*Department of Electronics and Telecommunication Engineering*

*K J Somaiya Institute of Technology, Mumbai, India*

p.gangapurwala@somaiya.edu,ishani.singh@somaiya.edu,shabda.satam@somaiya.edu

**Abstract**—Unmanned aerial vehicles (UAVs) are widely recognised for their capacity to conduct remote search operation over vast expanses of terrain, while circumventing the hazards associated with conventional manned aircraft. These aircraft are especially advantageous in scenarios where human intervention would pose a significant risk. A primary drawback associated with remote autonomous and unmanned systems pertains to their notably limited battery life, thereby constraining their duration of flight. Several technical methods and algorithms have been proposed to mitigate these issues and reduce the level of human oversight in the development of docking systems. Various techniques such as visual-based neural networks, deep reinforcement learning algorithms, fuzzy logic-based control systems, and the Sequential Deep Q-Network approach utilising the divide-and-conquer paradigm have been examined. The matter of loop shaping in the context of altitude control for unmanned aerial vehicles has also been addressed. This study presents a comprehensive analysis of multiple algorithms to determine their efficacy in achieving optimal docking results under varying environmental conditions.

**Index Terms**—UAV, neural networks, reinforcement learning, deep learning, fuzzy logic

## I. INTRODUCTION

The quadrotor helicopter, also known as a quadcopter, is classified as an unmanned aerial vehicle (UAV) and is equipped with four upward-facing rotors that allow for a wide range of manoeuvres within its designated operational parameters. In recent years, there has been a growing interest in the study of autonomous control systems for the purpose of deploying weapons, conducting surveillance, ensuring coastal security, and performing other hazardous tasks. The capacity to land is a crucial aspect of autonomous unmanned aerial vehicles. Autonomous systems are expected to increasingly dominate urban and home environments in the coming years. The forthcoming generation of unmanned aerial vehicles will require advanced controllers to navigate through turbulent environments and execute diverse tasks, such as transporting parcels and goods.

The limited battery life of small and affordable quadcopters is attributed to the weight of the batteries and the power consumption of the motors, resulting in a flight time of only a few minutes. Nevertheless, scholars are exploring methods to enhance the efficiency of quadcopters. Several researchers are exploring the strategy of restricting the flight duration of quadrotors and furnishing a base station that can function as a landing pad for battery preservation, hot swapping, or battery

recharging objectives. The global positioning system (GPS) and inertial measurement unit (IMU) sensor are commonly employed for navigation and automatic flight control purposes.

These sensors offer information regarding the position of unmanned aerial vehicles (UAVs) with a precision of 7.8 metres. The automatic flight control system comprises three distinct components, namely take-off, task performance, and landing. The safe take-off of a UAV quadcopter involves the determination of appropriate roll and pitch values to ensure stability, as well as the acquisition of height information necessary to achieve the desired altitude. The subsequent measure entails increasing the throttle solely up to the designated altitude. The subsequent stage involves executing an essential task, such as conducting surveillance, monitoring activities, or travelling to a distinct geographical area. The aforementioned tasks can be accomplished through the utilisation of GPS data. In addition, the utilisation of unmanned aerial vehicles in search and rescue (SAR) operations has been substantiated by research conducted within the last decade.

Numerous scholarly works have been published on the subject of system designs that integrate Unmanned Aerial Vehicles (UAVs) and Unmanned Ground Vehicles (UGVs) for the purpose of expeditiously reaching victims, or targets, while minimising risk to first responders and reducing operational expenses. Unmanned Aerial Vehicles (UAVs) are characterized by their high speed and low reliance on human intervention for successful navigation towards their intended targets. In missions that involve repetitive execution of flight phases, such as the pick and place operations mentioned earlier, it is crucial to optimise the landing procedure. The data provided by GPS is inadequate to achieve the required level of accuracy.

Consequently, it is imperative to employ multiple supplementary sensors, including a camera and LIDAR, to precisely determine their location on the platform and elevation. The LIDAR technology is utilised to measure the altitude of an unmanned aerial vehicle, whereas the camera is tasked with identifying the docking station or landing platform. The two most recent approaches utilised for safe landings are the position control approach and the velocity control method. The position control method transmits altitude directives slightly below the current altitude until the unmanned aerial vehicle (UAV) reaches ground level. The velocity control approach employs a mechanism that issues a constant command for downhill velocity until the ground level is reached.

II. LITERATURE SURVEY

In contemporary times, a multitude of algorithms and models have surfaced with the aim of enhancing the landing sequence of unmanned aerial vehicles (UAVs). Certain docking processes employ fixed targets, while others utilise moving targets, as implemented by various methods.

The quadrotor possesses three distinct operational modes, namely exploration, target tracking, and autonomous landing. The study described in [1] involves a theoretical scenario in which a quadrotor initiates its operation by lifting off from a designated location and subsequently enters an exploration phase. Following this, the quadrotor commences a predetermined search pattern with the aim of locating a specific target. Upon identifying the target markers, the quadrotor initiates tracking mode by utilising the Ar Track alvar package to approximate the position and orientation of the target. During the autonomous landing phase, the neural network controller utilises the published target positions to accurately guide the drone towards its intended landing point. The exploration

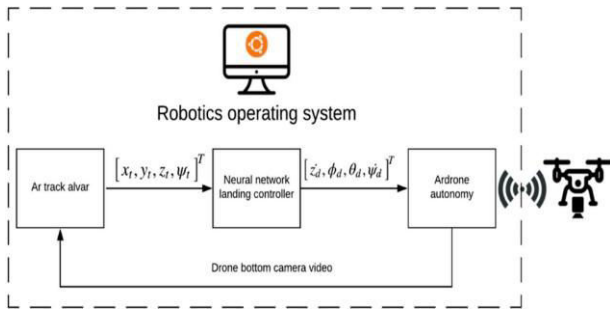

Fig.1. The experimental setup diagram with a real quadrotor system [1]

Mode of the drone was programmed to follow a predetermined course by utilising reference angles for the roll and pitch angles. Furthermore, the citation for the vertical velocity is provided. This simulation conducted by the system resulted in a triumphant touchdown on the pre-established objective. This simulation displayed the 3D exploration trajectory of the quadrotor, indicating the controllability of the system and the controller's ability to navigate the quadrotor to the designated reference angles. The progressive landing of the quadrotor on the designated platform is exemplified by this demonstration. The intelligent controller integrated within the drone effectively directed the landing process to the intended location, utilising the target positions provided by the target tracking package.

The proposed system, as documented in [2], trained the agent exclusively on low-resolution grayscale images, without necessitating close monitoring, manual feature generation, or specialised external sensors. The divide-and-conquer strategy was employed to break down a complicated task into sequential subtasks, with distinct DQNs allocated to each of them. The training process facilitated the acquisition of internal triggers that enable the automatic switching between policies.

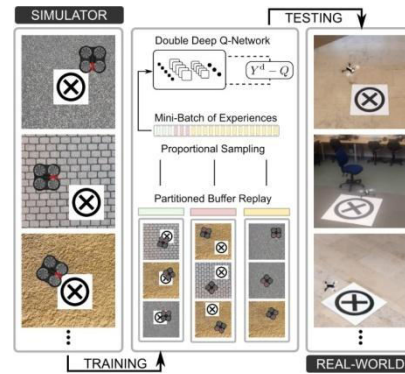

Fig.2. System overview and deployment using Deep Q-Network [2]

This novel category of networks has been denoted as Sequential Deep Q-Networks (SDQNs). A partitioned buffer replay was implemented to expedite the process of learning. Each partition within the buffer was designed to store experiences separately based on their relevance. The study involved the utilisation of SDQNs, partitioned buffer replay, and domain randomization to train a commercial UAV in simulation and subsequently test it in both simulated and real-world scenarios. The performances exhibited by the DRL algorithm were found to be on par with those of human pilots and a state-of-the-art algorithm. Additionally, the DRL algorithm was observed to leverage its unique capabilities, such as the ability to develop suitable features in diverse environments.

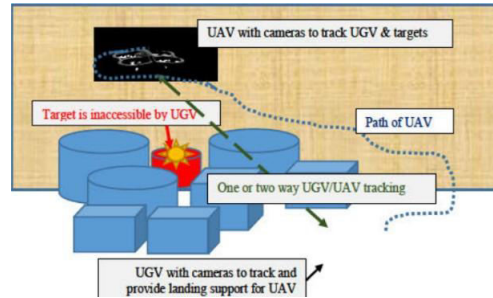

Fig.3. Sample scenario for cooperative UAV/UGV tracking system [3]

In the study as mentioned in [3], fuzzy controllers for regulating height and stationary hovering above a target were developed. Using the combination of open-source tools Fuzzy Lite, "ar track alvar," and ROS Gazebo with TUM ArDrone Simulator, simulation-based demonstration of the controllers was offered. The results of the simulation revealed that the altitude and landing controllers performed satisfactorily. For distributed systems, an extendable hardware and simulation environment was described. To govern the system's state transitions, the author intended to integrate the controllers using a fuzzy version of a state machine. For fuzzy control, it was proposed to use data mining and supervised learning to find the best inputs, rules, and membership functions based on historical flight data. Finding fuzzy inference algorithms that are best for flying in diverse situations and adapting

based on available sensor data was the aim of the learning process. The use of cloud-based processing nodes for improving the performance of the quadcopter and identifying targets from photos with little visual information content was a different avenue that the authors will investigate. The author has intended to improve tag detection for the quadcopter’s visual identification of the mobile base at wider distances and altitudes by combining different image processing approaches.

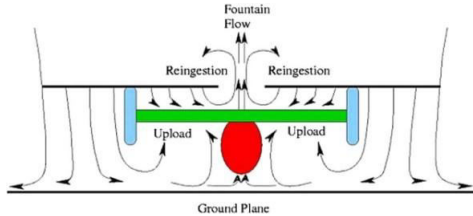

Fig.4. Quadcopter thrust effect under IGE [4]

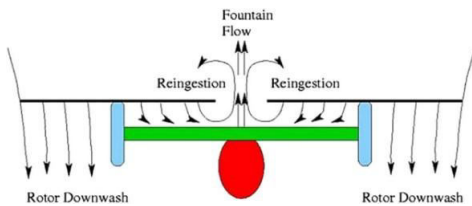

Fig.5. Quadcopter thrust effect under OGE [4]

The research as in [4] suggests a position and speed control auto-landing method based on fuzzy logic. This system was developed to control the quadcopter UAV system’s attitude using real-time position and velocity data. The quadcopter does not crash into the ground at high speed, which guarantees a safe landing due to velocity control algorithm. Position control checks altitude and generates directives to avoid IGE close to the ground for a rapid and smooth landing. In comparison to traditional controllers, this combination of position and speed control boosts efficiency by cutting down on landing time and offers the assurance of safety. When compared to a conventional fuzzy technique, the lookup table-based fuzzy logic technique reduced execution time and increased response time during landing. The suggested landing controller was put up against a traditional PID controller on a simulation environment. Results over the old method revealed a substantial improvement. In order to confirm the proposed method’s viability in the real world, it was also tested on a real quadcopter system. According to the results and validation, the real-time practical implementation suggests landing controller is considerably faster and safer than traditional methods. Without making any adjustments, this strategy can be used with all types of drones.

The utilisation of the Rolling Spider drone in [5] was employed to showcase the implementation of optimising the unmanned aerial vehicle’s landing procedure through experimentation. The empirical findings suggest that it is possible to

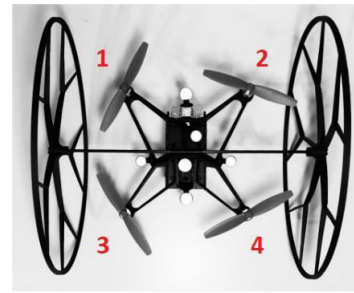

Fig.6. The experimental setup diagram with a real quadrotors system [5]

adjust the altitude controllers in a manner that achieves goal-oriented configuration of this control loop, thereby fulfilling specific dynamic requisites. The study additionally exhibited the methodology for executing such an adaptation within controlled experimental conditions. The Rolling Spider drone’s performance was evaluated by means of precise location measurements obtained through the use of a motion capture system, in conjunction with IMU-based measurements. The authors aim to expand their research scope to encompass marine-related tasks in their forthcoming work. The capacity to efficiently exchange the unmanned aerial vehicle in close proximity to the targeted item for retrieval is expected to hold significant value, while considering performance-based cost considerations. Furthermore, a study will be conducted to enhance the capacity to optimise the technique of landing in three-dimensional motion, while simultaneously mitigating disturbances caused by the opposing air flow resulting from the proximity to water.

### III. COMPARISON

TABLE I  
COMPARISON OF ALGORITHMS AND OPTIMIZATION OF MODELS

Data	Computing system / Algorithm	New Learning	Simulation Environment	Optimization
Targets, Coordinates and Controllers, Gazebo and ROS	Neural Networks	No	ROS and Gazebo	Possible
Low resolution Gray Scale Images	Sequential Deep Q-Networks	partitioned buffer replay	ROS and Gazebo	Possible
historical flight data	Fuzzy Controller and Supervised Learning, Velocity control algorithm.	No	ROS and Gazebo	Possible
Real time position and velocity data was used.	the lookup table-based fuzzy logic technique	No	ROS and Gazebo	possible
Mathematical Model Based environments were used	Fibonacci Search Algorithm, Optimization algorithm	No	MATLAB	Maximum optimized solution

### IV. PROPOSED MODEL

The aforementioned algorithms are utilised in visible light for the purpose of drone docking systems. The proposed

Drone docking system is deemed to be an optimal solution for accommodating drone docking needs, even in low light conditions. The paper discusses various methodologies that can be optimized to develop an efficient model that operates with reduced time consumption and smooth docking. The discussed methods do not present any obstacle avoidance system for the drone, which is a crucial aspect that needs to be addressed in the proposed model to enhance the reliability of the drone's landing and docking. The model under consideration employs an algorithm for obstacle avoidance, which enables the detection of obstacles and their avoidance through the utilisation of a camera. Upon detection of the tag through the utilisation of open CV, the landing sequence is activated and the unmanned aerial vehicle proceeds to securely dock on the designated landing pad.



Fig.7.ProposedModel

## V. CONCLUSION

At present, the drone docking stations are deficient in providing solutions for both illuminated and non-illuminated environments. Insufficient research has been conducted on the utilization of targets for docking in low-illumination environments, which could yield comprehensive outcomes for both diurnal and nocturnal conditions. The complexity and cost of these systems are contingent upon the specific demands of the environmental conditions. There exists a requirement for a solution that is more adaptable to various environments and situations. The suggested approach involves integrating current solutions with appropriate modifications to enhance the efficacy of autonomous systems in facilitating the successful landing of unmanned aerial vehicles (UAVs).

## Acknowledgment

The authors thank Dr. Jayashree V. Khanapuri and Dr. Deepak Mishra for their guidance and support that was required for accomplishing the goal of the paper. The author also thanks the Electronics and telecommunication Department for kind support. Last but not the least I would like to thank the college to provide the necessary support and opportunity to present my views and research on the topic.

## References

- [1] Almeshal, A.M.; Alenezi, M.R. A Vision-Based Neural Network Controller for the Autonomous Landing of a Quadrotor on Moving Targets. *Robotics* 2018, 7, 71.
- [2] Polvara, R.; Patacchiola, M.; Hanheide, M.; Neumann, G. Sim-to-Real Quadrotor Landing via Sequential Deep Q-Networks and Domain Randomization. *Robotics* 2020, 9, 8.
- [3] Benavidez, P.J.; Lambert, J.; Jaimes, A.; Jamshidi, M. Landing of a Quadcopter on a Mobile Base Using Fuzzy Logic. In *Advance Trends in Soft Computing*; Jamshidi, M., Kreinovich, V., Kacprzyk, J., Eds.; Springer International Publishing: Cham, Switzerland, 2014; pp. 429–437.
- [4] Talha, M.; Asghar, F.; Rohan, A.; Rabah, M.; Kim, S.H. Fuzzy logic-based robust and autonomous safe landing for UAV quadcopter. *Arab. J. Sci. Eng.* 2019, 44, 2627–2639.
- [5] Horla, D.; Giernacki, W.; Cieslak, J.; Campoy, P. Altitude Measurement-Based Optimization of the Landing Process of UAVs. *Sensors* 2021, 21, 1151.

# A Comparative study of different algorithms for Fake News Detection using Machine Learning

Diksha Madhav Bhalerao  
Computer Science Engineering  
Bharati Vidyapeeth Deemed to be  
University, Navi Mumbai  
Navi Mumbai, India  
dmbhalerao@bvucoep.edu.in

Anmaya Mohapatra  
Computer Science and Business System  
Bharati Vidyapeeth Deemed to be  
University, Navi Mumbai  
Navi Mumbai, India  
anmaya.m9@gmail.com

Ishita Thakur  
Computer Science and Business System  
Bharati Vidyapeeth Deemed to be  
University, Navi Mumbai  
Navi Mumbai, India  
ishitathakur@protonmail.com

Vedika Gosavi  
Computer Science and Business System  
Bharati Vidyapeeth Deemed to be  
University, Navi Mumbai  
Navi Mumbai, India  
vedika.gosavi09@gmail.com

Divyashil Agale  
Computer Science and Business System  
Bharati Vidyapeeth Deemed to be  
University, Navi Mumbai  
Navi Mumbai, India  
divyashilgraphics@gmail.com

**Abstract**—With the increased usage of the internet more and more people have liberty to post information without any editing or approval required; this has manufactured a breeding ground for misinformation or false news to be spread amongst the general population. There have been numerous attempts to solve the fake news crisis by building detection apps, extensions and websites, all of them use different algorithms, some more accurate than others. A handful of researchers have tackled this challenge and studied various algorithms for the sole purpose of detecting fake news with the most accurate results. Therefore this research paper evaluates the five most commonly used machine learning algorithms to provide a performance comparison on the metrics accuracy, precision, recall and f1 score. The dataset that we will be using is the Fake News dataset from Kaggle and the input variable will be Term-Frequency and Inverse Document Frequency (TF-IDF). The five algorithms we compare are: Logistic Regression (LR), Random Forest (RF), Decision Tree (DT) and Support Vector Machine (SVM).

**Keywords**—Fake News Detection, Machine Learning, Logistic Regression, SVM, Random Forest, Decision Tree

## I. INTRODUCTION

Fake News is an umbrella term that is used to encompass meaning of every information that is either misleading, not entirely true, completely false, fabricated or even exaggerated; this can include articles or text chains that spread rumours, edited videos and audio that lose the original meaning when taken out of context and, digitally manipulated photographs. The Motive behind deliberately circulating False information can range from individuals desiring virality for monetary gain to individuals or groups desiring to defame or slander someone they dislike or detest. Fake News is an intimidating piece of media as it has the capacity to garner more attention [2] from a naïve and gullible audience due to the sheer nature and even absurdity of the false narrative that is permeating. It has the potential

to cause changes in an individual's perception, make them lose trust in other individuals or organisations and even cause political and socio-economic divide. The internet and the information that is consumed on it is a product of algorithms that favour high interaction from users and an inefficiency in cross checking every post with trustable sources to back up the credibility of information that is being shared over and over.

Since the age of personalised home computers and the increased use of the internet, there has been a rise in the circulation of false information. From the infamous 2016 "Nigerian Prince Scam" [1], that involved a US student stealing millions of dollars through fake emails, to the more recent text chains on WhatsApp that were involved in fear-mongering gullible citizens about the status of the 2020 pandemic, Fake News has become an integral part of modern day society and poses a significant threat in our communications system. There is an increased development of websites and social media platforms that provide the general public a greater autonomy to post or publish any and all kinds of information on one's own volition without going through an editorial process which leads to a platform saturated in biases of a common person; This creates a perfect environment for breeding of misinformation since an average person will take things at face value rather than spending their valuable time fact checking every little thing they read or hear on the internet. Furthermore, it is becoming increasingly difficult to ascertain what information is based in reality and what has been fabricated or taken out of proportion, with multiple news and media outlets reporting on the same bulletin with each report slightly offset from each other. Ergo, there is an immense need, now more than ever, for innovation in this sector that can help solve the Fake News crisis.

With the aforementioned points in mind there have been countless attempts to tackle the fake news issue through the use of different machine learning classifiers. Different sources claim different classifiers to be more effective and efficient, therefore, in this paper we compare five major

classifiers in terms of accuracy, precision, recall and F1 score with the key input feature as TF-IDF.

## II. LITERATURE REVIEW

Eugenio Tacchini et. al.[6] in their paper found Logistic Regression to have on average 99% accuracy on a dataset with over 15,000 Facebook posts from 32 pages. When creating their dataset they found hoax posts to have, on average, more likes than non-hoax posts. Therefore, they theorised that posts can be classified as either hoax or non-hoax depending on the profiles that like them and the relation between the number of users liking hoax & non-hoax posts. The paper also points out that while Logistic Regression gives a high accuracy, it is restricted to be only performed on a large and uniform set of features and in this case, LR does not transfer information across facebook users who have an overlap in the types of posts they like.

Md Gulzar Hussain et. al. [10] in their paper compare Support Vector Machine and Multinomial Naïve Bayes (MNB) on a dataset of 1,200 Bangle news articles amassed from various online news portals. They found that, while SVM and MNB both achieve high accuracy, SVM slightly outperforms MNB. With the feature Bag of Words, SVM achieves the highest accuracy of 97.33%, followed by 96.17% accuracy with the feature Term Frequency & Inverse Document Frequency (TF-IDF). In their research, they suggest that the use of stemmer can minimise corpus size and enhance model efficiency.

Gowthami. K. et. al. [12] in their paper compared SVM and Random Forest classifiers on the Kaggle dataset for social media. Their dataset consisted of 250 entries of twitter posts or tweets, and 22 attributes such as creation time, length, user id, user followers count, retweet count and more. They found Random Forest to have an accuracy of 98% and SVM with 70% accuracy.

G. Sakthi et. al. [17] in their paper found Decision Tree to have an accuracy of 89.11% when compared to Random Forest which achieved an accuracy of 84.97%.

The study conducted by Chaitra K Hiramath et. al.[3] in 2019 aimed to detect fake news using various deep learning techniques. The techniques used in the study were Logistic Regression, Naive Bayes, Support Vector Machine, Random Forest, and Deep Neural Network. The results showed that Deep Neural Network (DNN) achieved the highest accuracy of 91% with the least amount of execution time. However, it required the highest amount of memory compared to other techniques used in the study. On the other hand, Logistic Regression (LR) required the least amount of memory. The study concluded that deep learning techniques are effective in detecting fake news and the choice of technique should be based on the tradeoff between accuracy and resource requirements. DNN has the advantage of high accuracy but may require more memory resources, while LR has the advantage of low memory requirements but may have lower accuracy.

In 2018, Monther Aldwairi et. al.[4] conducted a study to detect fake news in social media networks. The study used four different techniques: BayesNet, Logistic Regression (LR), Random Tree, and Naive Bayes. The

study found that LR achieved the highest precision, recall, and F-measure, with scores of 99.4%, 99.3%, and 99.3%, respectively. However, the study also found that LR falls short of a few percentage points compared to BayesNet and Naive Bayes, which had the best area under the ROC curve at 100%. These results indicate that LR is a highly effective technique for detecting fake news in social media networks, with very high precision, recall, and F-measure. However, it may not be the most effective technique overall, as BayesNet and Naive Bayes were found to have better overall performance according to the area under the ROC curve. Therefore, the choice of technique for detecting fake news may depend on the specific needs and goals of the task at hand.

Abdullah-Al Tanvir et. al.[5] conducted a study in 2019 to detect fake news using various machine learning and deep learning algorithms. The study used Support Vector Machine (SVM), Logistic Regression (LR), Naive Bayes (NB), Long Short-Term Memory (LSTM), and Recurrent Neural Network (RNN) algorithms. The study found that SVM achieved the highest accuracy of 89.34% after cross-validation using TF-IDF and Count Vector techniques. On the other hand, LR achieved a higher accuracy than SVM before cross-validation, but it was found to be vulnerable to overconfidence. The study highlights the importance of cross-validation in achieving accurate results and avoiding overconfidence in the accuracy of the model. The findings also suggest that SVM may be a more effective technique for detecting fake news compared to LR in this particular study. However, the choice of technique may depend on the specific dataset and the goals of the task at hand.

In 2020, Reham Jehad Al-Shammari et al. [11] conducted a study on fake news classification using the Random Forest (RF) and Decision Tree (DT) algorithms. They used a dataset from Kaggle and feature selection was performed using TF-IDF. The study found that RF achieved an accuracy of 84.97%, while DT achieved an accuracy of 89.11%. The results indicated that DT outperformed RF in terms of accuracy. However, the authors recommended using more powerful classification algorithms such as Deep Neural Networks (DNN) like Long Short-Term Memory (LSTM), Gated Recurrent Unit (GRU), or Convolutional Neural Network (CNN) in future studies to improve the accuracy of fake news classification. This suggests that more advanced algorithms may be necessary to achieve higher accuracy in detecting fake news.

The study by KasraMajbouriYazdi et. al.[10] (2020) proposes the use of a combination of K-means clustering and SVM classification for improving the accuracy and efficiency of fake news detection. The study suggests that using K-means clustering can help to improve feature selection, which can then be used as input for SVM classification. The results of the study show that the combination of K-means clustering and SVM achieved higher accuracy and efficiency compared to using SVM alone. However, the study is limited by a small dataset and lack of comparison with state-of-the-art approaches. Additionally, the study does not provide a detailed explanation of the K-means clustering algorithm and its implementation.

In 2022, R.S. Karthikaa[14] conducted a study on detecting fake news using the Support Vector Machine (SVM) algorithm. The study successfully developed and evaluated a model that achieved an accuracy rate of 89.5% in detecting fake news. However, the study also noted that the dataset used in the study was limited and more diverse datasets could be included in future research to improve the generalizability of the model. This suggests that the effectiveness of the SVM algorithm in detecting fake news may depend on the specific dataset being used, and a more diverse dataset may be necessary to achieve accurate results in different contexts.

In Poonam Tijare's [8] (2019) study on fake news detection, four algorithms were tested: Naïve Bayes, SVM, LSTM, and Neural Networks. The LSTM algorithm performed the best, achieving an accuracy rate of 94.5%. However, the study notes the need for further research to improve the performance of these algorithms and to address the issue of detecting misinformation in real-time.

### III. COMPARATIVE ANALYSIS.

#### A. PROPOSED SYSTEM

To understand the results of our study let's first take a look at our proposed system.

- Programming Language: Python was chosen for its powerful machine learning and data manipulation libraries.
- System: Google Colab was chosen for the simplicity of its usage.
- Dataset: the Fake News dataset on Kaggle was deemed appropriate due to its simplicity of labelled articles in the English language with over 25,117 entries.
- Classifiers: Logistic Regression, Random Forest, Decision Tree, Support Vector Machine and Long-Short Term Memory have been chosen for this study.
- Feature Selection: in this study the feature Term-Frequency and Inverse Document Frequency (TF-IDF) was chosen to present with a generalised result that could fit with the different classifiers in the study.
- Performance Metrics: The aforementioned classifiers are evaluated on their accuracy, precision, recall and F1-score. Below is the block diagram of the proposed system:

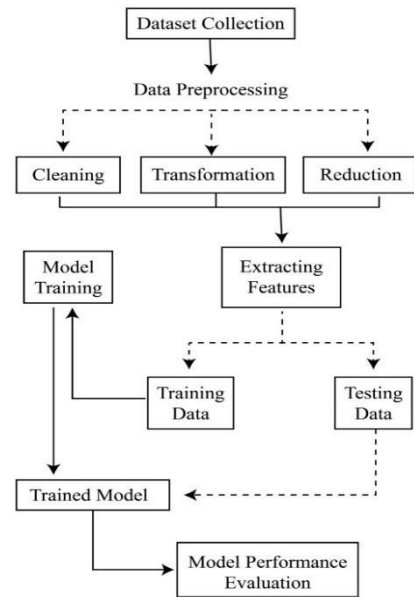

Fig 1.0: block diagram of the system

#### B. Implementation

The following are the steps taken in this study:

##### Step 1: import libraries

The most crucial libraries to be imported were: *pandas* for loading dataset, *sklearn.model\_selection* for splitting dataset into training and testing groups, *sklearn.feature\_extraction.text* for converting document into a matrix of TF-IDF features and lastly, *sklearn.metrics* for evaluating accuracy, precision, recall and F1 score.

##### Step 2: loading the dataset

The dataset from Kaggle was downloaded onto a computer system as a zip file which was then extracted to obtain the .csv file which then was imported to Google Colab. To ensure that all the data was readable it was encoded as UTF-8 (Uniform Transformation Format).

##### Step 3: clean the dataset

In the .csv file, the rows that contained null value were removed with the use of *dropna()* function. Furthermore, the dataset was cleaned by removing punctuations, digits and, converting all letters to lowercase.

##### Step 4: extracting features

For all the classifiers, the only feature that was extracted as an independent variable was TF-IDF with the use of *Tfidfvectorizer()* function with the built-in stop words in python libraries for the english language.

##### Step 5: splitting the dataset

The 25,117 articles long dataset was split into a training group and a testing group using the *test\_train\_split()* function. The four objects to this function were X\_train, X\_test, y\_train, y\_test. The test size was 0.2 which meant that 20% of the dataset was reserved for testing only and 80% of the dataset was used for training the models for classifiers. Furthermore, to ensure that split is

deterministic and reproducible a random state was given to the `test_train_split()` function with the value of 42.

**Step 6: training the classifiers**

For Logistic Regression, Random Forest and Decision Tree, the built in python classifiers were called and the dataset was fit into it with the use of the function `model.fit(X_train, y_train)` where `X_train` is a matrix of input features and `y_train` represents a vector of corresponding binary output label. For Example, if there is an article in the dataset with the title “Trump decides to join war against Ukraine!! “Enough is Enough,” he says” with the label False, then the `X_train` value would be “Trump was Ukraine” and the `y_train` would be False.

**Step 7: making predictions on test data**

For all the classifiers the `predict()` function was used with the argument as `X_test`. Where `X_test` is the data to be tested, with the function returning the dependent variable, which is either True or False in this case, based on the trained model.

Below is the flowchart demonstrating the implementation of the study:

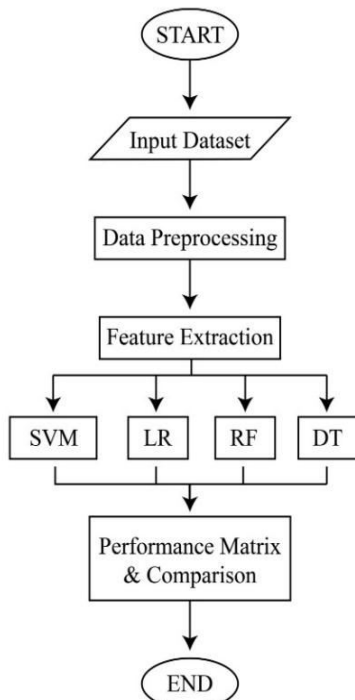

Fig 2.0: Flowchart of the system

**Step 8: calculating performance metrics**

All the classifiers were measured for accuracy, precision, recall and f1 score with the functions `accuracy_score()`, `precision_score()`, `recall_score()` and `f1_score()`, with the arguments `y_test` and `y_pred`.

**C. Results**

**a) Accuracy:**

It refers to the number of correct predictions. For binary classification, it can be calculated in terms of positives and negatives:

$$\text{Accuracy} = \frac{TP + TN}{TP + TN + FP + FN}$$

Where TP = True Positives, TN = True Negatives, FP = False Positives, and FN = False Negatives

In this study SVM outperforms every other classifier by achieving the highest accuracy of 97% in the training data.

**b) Precision :**

It refers to the number of truly positive outcomes from all the positive outcomes. It is calculated as the ratio of all true positives over the sum of all positives:

$$\text{Precision} = \frac{TP}{TP + FP}$$

In this study SVM outperforms all other classifiers by achieving a precision score of 97% in the training data..

**c) Recall :**

It refers to the number of correctly predicted true outcomes and is calculated as the ratio of true positives over a sum of true positives and false negatives.

$$\text{Recall} = \frac{TP}{TP + FN}$$

In this study SVM outperforms all other classifiers by achieving a recall score of 97% with the training data.

**d) F1 Score:**

F1 score is predominantly used for binary classification of data and because of that it is an apt measure for the classifiers as the output in the fake news detection system is also binary i.e. true or false. It refers to the weighted average mean of precision and recall and is calculated as follows:

$$\text{F1 Score} = \frac{\text{Precision} * \text{Recall}}{\text{Precision} + \text{Recall}} * 2$$

Again, SVM outperforms all other classifiers by achieving a F1 score of 97% with the training data.

	Accuracy	Precision	Recall	F1 Score
<b>Logistic Regression</b>	0.89	0.89	0.80	0.84
<b>Random Forest</b>	0.65	0.64	0.47	0.54
<b>Decision Tree</b>	0.74	0.80	0.53	0.64
<b>SVM</b>	0.97	0.97	0.97	0.97

Table 1.0 :Metric Values of Training Dataset

	Accuracy	Precision	Recall	F1 Score
Logistic Regression	0.91	0.91	0.91	0.84
Random Forest	0.90	0.90	0.90	0.54
Decision Tree	0.82	0.82	0.82	0.64
SVM	0.91	0.90	0.91	0.97

Table 2.0: Metric Values of Testing Dataset

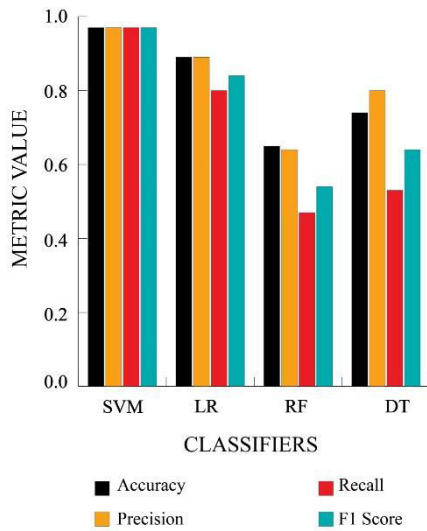

Graph 1.0 : Result Graph of Training Dataset

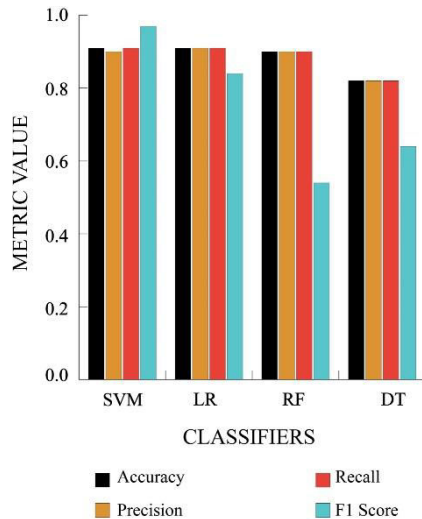

Graph 2.0 : Result Graph of Testing Dataset

IV. CONCLUSION

Fake News, Hoax, or misguided information have long been an epidemic for the human society, but with the rise of personalised technology and the internet, the issue has become more pressing to say nonetheless. Therefore, the goal of this paper is to analyse a few of the methods that can be used to solve the fake news issue and present with a novel finding. The TF-IDF attribute was extracted from the Kaggle dataset and fed as an input feature to the machine learning models. Various classifiers, Logistic Regression (LR), Random Forest (RF), Decision Tree (DT) and Support Vector Machine (SVM) were evaluated on the performance metrics of accuracy, precision, recall and f1-score. The results of the comparison deemed SVM to be the best classifiers for this particular dataset with the TF-IDF feature. It is definitely possible that if a different dataset or input feature were to be chosen, another classifier might reach the same or even higher performance score. It is to be noted that each classifier serves a different function and the results are susceptible to changes according to the dataset chosen, the data preprocessing method and the features extracted as inputs to the machine learning models.

REFERENCES

[1]“Advanced-fee scam”, Wikipedia, The Free Encyclopedia. Wikipedia, 23 December 2022.

[2]G. Pennycook, “The Psychology of Fake News.” Trends in Cognitive Science. Vol. 25, no. 5, 2021, p388-402. Science Direct, <https://doi.org/10.1016/j.tics.2021.02.007>

[3]C. K. Hiramath and G. C. Deshpande, "Fake News Detection Using Deep Learning Techniques," 2019 1st International Conference on Advances in Information Technology (ICAIT), Chikmagalur, India, 2019, pp. 411-415, doi: 10.1109/ICAIT47043.2019.8987258.

[4]MontherAldwairi, Ali Alwahedi, “Detecting Fake News in Social Media Networks”, Procedia Computer Science,Volume 141, 2018, Pages 215-222, <https://doi.org/10.1016/j.procs.2018.10.171>.

[5]Abdullah-All-Tanvir, E. M. Mahir, S. Akhter and M. R. Huq, "Detecting Fake News using Machine Learning and Deep Learning Algorithms," 2019 7th International Conference on Smart Computing & Communications (ICSCC), Sarawak, Malaysia, 2019, pp. 1-5, doi: 10.1109/ICSCC.2019.8843612.

[6]Eugenio Tacchini et. al., “Some Like it Hoax: Automated Fake News Detection in Social Networks,” SoGood 2017 - Second Workshop on Data Science for Social Good. Vol 1960, 2017.

[7]S. Vinothkumar et. al., "Fake News Detection Using SVM Algorithm in Machine Learning," 2022 International Conference on Computer Communication and Informatics (ICCCI), Coimbatore, India, 2022, pp. 1-7, doi: 10.1109/ICCCI54379.2022.9740886.

[8]Poonam Tijare, “A Study on Fake News Detection Using Naïve Bayes, SVM, Neural Networks and LSTM,” Journal of Advanced Research in Dynamical and Control Systems (JARDCS), Vol. 11, Issue 06, p942-947, 2019.

[9]KasraMajbourni Yazdi et. al., “Improving Fake News Detection Using K-means andSupport Vector Machine Approaches,” International Journal of Electrical, Electronics and Communication Sciences (IJECS), 2020, <https://doi.org/10.5281/zenodo.3669287>.

[10]M. G. Hussain et. al., "Detection of Bangla Fake News using MNB and SVM Classifier," 2020 International Conference on Computing, Electronics & Communications Engineering (ICCECE), Southend, UK, 2020, pp. 81-85, doi: 10.1109/ICCECE49321.2020.9231167.

[11]R. Jehad and S. A. Yousif, “Fake News Classification Using Random Forest and Decision Tree (J48),” Al-Nahrain Journal of Science (ANJS), vol. 23, no. 4, pp. 49-55, Nov. 2020.

[12]Gowthami K. et. al., "Identification of Fake News through SVM and Random Forest," International Journal of Engineering Science and Computing (IJESC), Vol. 10, Issue 10, 2020.

[13]G. Sakthi, "Fake News Detection using Machine Learning employing Decision Tree Algorithm," International Journal of Emerging Technologies and Innovative Research (JETIR), Vol. 9, Issue 6, 2022.

[14]K. Harshitha et. al., "Fake News Detection" International Journal of Engineering Research and Technology (IJERT), Vol. 11, Issue 7, 2022.

# Soil Doctor: The Farming Solution

1<sup>st</sup> Dr . Ashwini. B. Gavali

*Department of Computer Engineering*  
SavitribaiPhule Pune University  
Indapur, India  
pdnyaneshwar806@gmail.com

2<sup>nd</sup> PallaviVijaykumarJathar

*Department of Computer Engineering*  
SavitribaiPhule Pune University  
Indapur, India  
pallavijathar940@gmail.com

3<sup>rd</sup> Vaishnavi Vishnu Kadam

*Department of Computer Engineering*  
SavitribaiPhule Pune University  
Indapur, India  
kadamvaishnavi3006@gmail.com

4<sup>th</sup> Mr. RushikeshSanajyChinchkar

*Department of Computer Engineering*  
SavitribaiPhule Pune University  
Indapur, India  
rushichinchkar2227@gmail.com

5<sup>th</sup> Miss. Shreya DilipVedpathak

*Department of Computer Engineering*  
SavitribaiPhule Pune University  
Indapur, India  
shreyavedpathak55@gmail.com

**Abstract**—A crop’s productivity is affected by the soil, fertilizers, and water. For cultivating vegetables, fertilizers include micronutrients like zinc, nitrogen, and others. Details about various factors, goods, and the operational environment can be obtained through the sensors to send and receive data between the various devices and from a distant server. his paper presents the study of the colorful data mining ways used for prognosticating crop yield.this is lacking behind in using new technologies of machine learning. Hence our farmers should know all the new technologies of IOT and other new techniques. These techniques help in getting the maximum yield of crops.

**Index Terms**—Internet of Things (IoT), Sensors, Crop recommendation, Crop prediction.

## I. INTRODUCTION

Agriculture is one of the most important professions practiced in India. It is a very important economic sector and plays a most important role in the overall development of the country. It also contributes a large portion of employment [1]. Researchers have started offering solutions by integrating the Internet of Things with deep learning techniques, or “Smart IoT,” to feed food for an increasing population in nations like India [2][6]. Because of this development, e-farming has adopted a new pattern in which all the sensors required for farming are linked to the distant server through wireless or remote protocols in a distributed setting. The farmers can keep an eye on these fields even when they are a long way away thanks to their intelligence [3]. In a rainy season, the data from various sensors is translated into a single, computable format so that the specified framework can deal with it IoTbased Smart Farming improves the entire agriculture system by monitoring the field in real-time. It keeps various factors like humidity, temperature, moisture of soil, etc. under check and gives a crystal-clear real-time observation. The design paper consists of seven sections. In the first section, we have given information about the

existing system and proposedsystem. In the previous system, they use the KNN algorithm for predicting crops. In our system, we use the convolutional neural network (CNN) algorithm and DH11 and moisture sensor to detect the temperature, humidity, and moisture of the soil. The second section consists of the system architecture of the project. The next section includes the data flow, and use case of the project. Advantages are the fifth section. In the next section, we have described the application and the last section is about the conclusion in which we have improved the performance and accuracy of an existing system case.

## II. EXISTING SYSTEM

In the existing system they have introduced distinctive ML calculations, for example, k implies, SVM, ANN, and so on. The harvests were anticipated for the most part dependent on climatic highlights which gives an exactness score of about 95 percentage with the C4.5 calculation. Tried to train the model with decision trees but found that random forest algorithm reduced the overfitting problem and also improved accuracy and used SVR, Random forest and random forest got more accuracy. This research work can be enhanced to a high level by building a recommender system of agriculture production and distribution for farmers [1].

## III. PROPOSED SYSTEM

Data pre-processing in problem-solving is regarded as an important machine learning phase. Pre-processing is extracting the functionality adding the correct gathered data, and adding the missing values. The format of the data set is difficult for the analysis process. Pre-processing the data is regarded as a critical step in the machine learning process. Pre-processing entails adding the correct collection of data,

missing values, and functionality extraction. The amount of data required to characterize a large collection of data would be less if the features were extracted. The training data collection is determined by the soil, crop, features and meteorological data gathered throughout the pre-treatment procedure.

**A. Problem Statement**

Due to India’s harsh weather, crops may become submerged in water as a result of heavy rains and flooding. This renders the soil’s moisture level inadequate for high yield. Each crop has a range of soil water content that influences production. Temperature and humidity are two more elements that have an impact on crop output. As a result, they must be kept within their specific ranges for each crop variety. The implementation of our project will address this problem. It aids farmers in preventing excessive waterlogging of their crops.

**B. System Architecture**

The system architecture consists of hardware and software systems. In the software system, we have given input as a soiled image by using the convolutional neural network (CNN) algorithm we extract the features of the soil and pre-process the image and then the system gives the output and which predicts the soil type and suitable crop for input soil image. In the hardware system, we have used two sensors i.e. DHT11 and Moisture sensors which detect the humidity temperature, and moisture of particular soil.

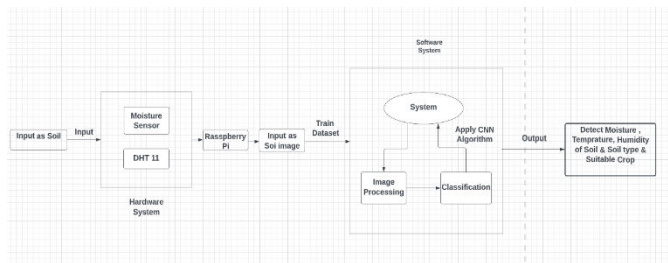

Fig. 1. System Architecture

**C. Hardware Interfaces**

- RAM: 8 GB As we are using Machine Learning Algorithm and Various High-Level Libraries Laptop RAM minimum required is 8 GB.
- Hard Disk: 40 GB Data Set of CT scan images is to be used hence a minimum of 40 GB Hard Disk memory is required.
- Sensors: Moisture Sensor, DHT 11

- Processor: Intel i5 Processor

**D. Software Interfaces**

- Software: anaconda navigator
- IDE: Spyder Best Integrated Development Environment as it gives possible suggestions at the time of typing code snippets that make typing feasible and fast.
- Coding Language: Python Version 3.5 highly specified Programming Language for Machine Learning because of the availability of High-Performance Libraries.
- Operating System: Windows 10 Latest Operating System that supports all types of installation and development Environments

**E. Data Flow Diagram**

In this section, the following figure shows the data flow of the system which consists of input and output processing.

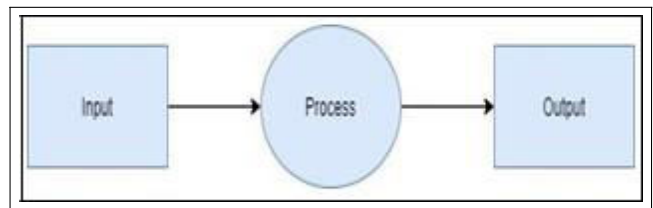

Fig. 2. Data Flow(0) diagram

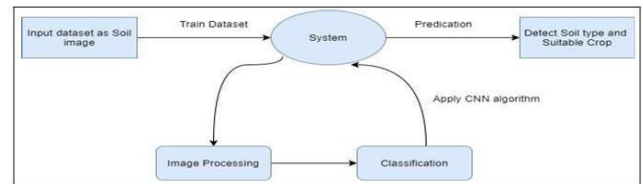

Fig. 3. Data Flow(1) diagram

**F. Usecase Diagram**

Due The use case diagram section gives information about the interrelation between the user and the system.

Fig. 4. Use case diagram

**G. Advantages**

- By using sensors we detect moisture, humidity, temperature, etc. of soil.

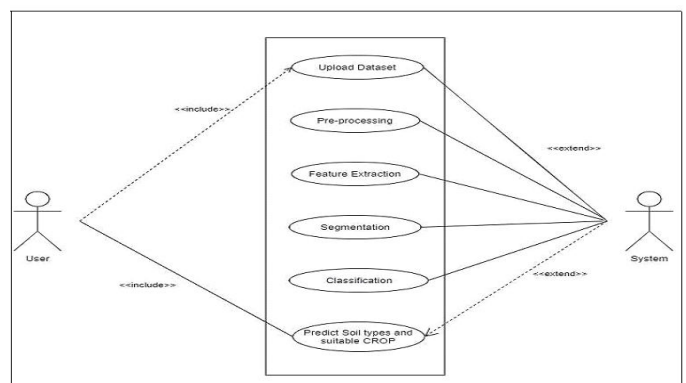

- Predicting the productivity of crops in different climatic conditions can help farmers and can be helpful for increasing the productivity of crops.
- This model can be used to select the better crops for the region and also its yield thereby improving the values and gain of farming.

H. Application

- Agricultural Applications means applications relating to Cultivating, characterizing, or modifying soil and improving productivity.
- Producing, growing, improving, and protecting are some of the important characteristics of a farm identifying these characteristics can be helpful.
- It is mainly used in the selection of crops for yielding.
- It can be applicable to terrace gardening also.
- It might be used for nurseries.
- It is a short time solution for farmers.

IV. RESULT

Here in this section, we are going to see the results. The first window page is about the Home Page of the system. It consists of two options login and registration option for end users. If we have already registered then we can log in to the page if not then register for a new account and create a user I'd and password for a particular user for login.

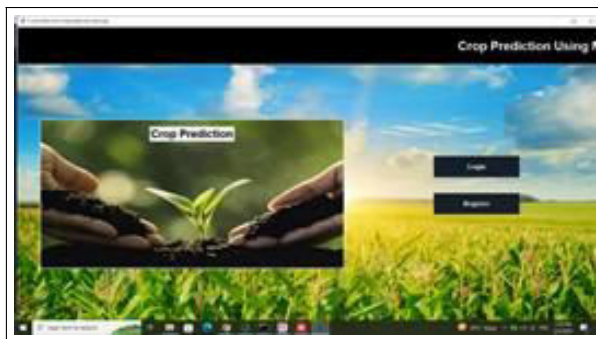

Fig.5.HomePage

The second figure is about the login page. We can log in by entering User Name and password. If not register an account then go to the register page.

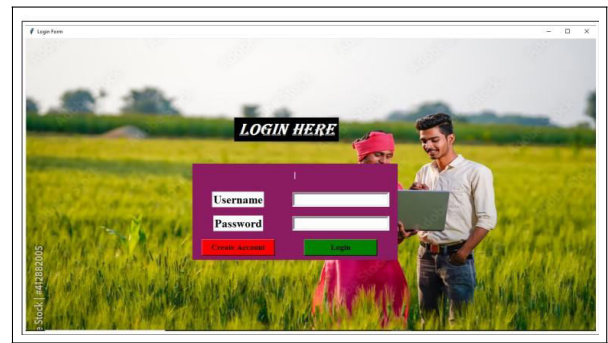

Fig. 6. Login Page

The registration form is the third window through which can create an account by filling in the following details of the user they are Full Name, Address, Email, Phone No., Gender, Age, User Name, and Password.

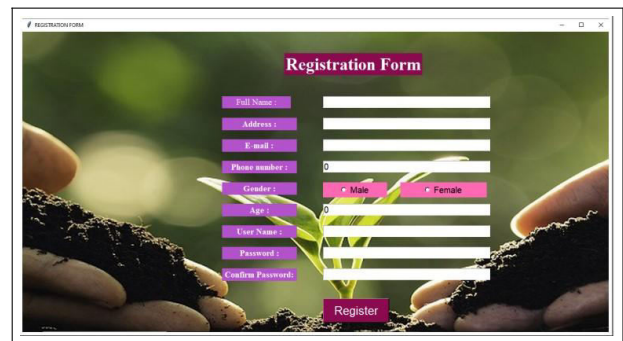

Fig.7.RegistrationPage

The last window is the result page. By selecting the image of soil from the dataset and by applying the convolutional neural network (CNN) algorithm we predicted the suitable crop.

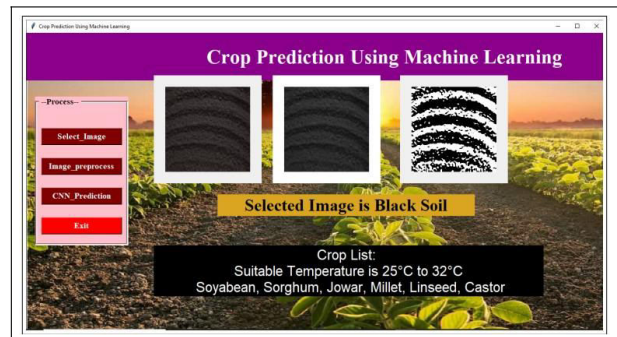

Fig.8.MainOP

## V. COMPARATIVE STUDY

In the existing system, traditionally without knowing the type of soil, without knowing suitable crop Farmer plants his farm and it many times gives him loss. Farmers don't have knowledge of crop and soil also. We need to know the features and characteristics of various soil types to understand which crops grow better in certain soil types. Machine learning techniques can be helpful in this case. Then apply the apriority Mining process to generate an association rule for finding suitable crops for the specific soil. Soil series and land type combine represents the soil class in the database. The machine learning methods are used to find the soil class (i.e. soil series and land type). Algorithm are used: convolutional neural network (CNN).

## VI. CONCLUSION

Agriculture is the field that helps in the economic growth of our country. But this is lacking behind in using new technologies of machine learning. Hence our farmers should know all the new technologies of IOT and other new techniques. These techniques help in getting the maximum yield of crops. Many techniques of IOT are applied in agriculture to improve the yield rate of crops. These techniques also help in solving the problems of agriculture. We can also get the accuracy of yield by checking for different methods. Hence we can improve the performance by checking the accuracy between different crops.

## REFERENCES

- 1 Supervised Machine learning Approach for Crop Yield Prediction in Agriculture Sector. Dr. Y. Jeevan Nagendra Kumar<sup>1</sup> V. Span dana <sup>2</sup> , V.S. Vaishnavi<sup>3</sup> , K. Neha<sup>4</sup> ,(2020).
- 2 Soil Classification and Crop Suggestion using Machine learning techniques. Periasamy J.K (2021).
- 3 [Soil Classifications n Crop Suggestion based on HSV, GLCM, Gabor Wavelet Techniques and Decision Tree Classifier in Image Pro. 1 abimala.rajendr an@gmail.com 2 sashyaflora@gmail.com 3 sripriya2198@ gmail.com [(2020).
- 4 Real-Time Monitoring of Agricultural Land with Crop Prediction and Animal Intrusion Prevention using the Internet of Things and Machine Learning at Edge. Nikhil R Prof.Anisha B S Dr.Ramakanth Kumar P (2020).
- 5 CROP PREDICTION USING PREDICTIVE ANALYT-ICS. P. S. Vijayabaskar, Sreemathi.R, Keertanaa.E(2017).

# Intelligent Cancer Prediction and Analysis System Based on Deep Learning Techniques

Prathamesh Siddharam Birajdar  
Student MTech (CSE),  
Walchand Institute of Technology  
Solapur

Dr. L.M.R.J. Lobo  
Professor (CSE)  
Walchand Institute of Technology  
Solapur

Mr. S. T. Patel  
Assistant Professor  
Walchand Institute of Technology  
Solapur

**Abstract** - In the world of medicine, cancer screening is still a highly touchy and contentious subject. An analysis of publicly available data reveals numerous points of view based on a small amount of valid information. The ideal age ranges for mammography screening, as well as the worth of the procedure itself, are still up for debate. Ultimately, the usefulness of lung or prostate cancer screening remains in question. Reliable evidence, not good intentions, presumptions, or supposition, should be the foundation for recommendations and decisions for cancer screening. Understanding the underlying ideas and presumptions is essential in order to fully understand the present challenges related to testing for blood, prostate, and breast cancers. The probable financial, legal, and radiation safety impacts of entire-body CT or PET cancer screening will be covered in this paper. The patient's body is scanned and images are preserved. Now using PET/CT abnormalities or cancer tissues are detected in the images. The body parts effected by cancer are localized. A classification is then generated regarding the type of cancer and the stages of the cancer are identified. A model is then created which automatically uses machine learning algorithms to do the task of prediction. The complete process is thus automated.

**Index Terms**– PET/CT scan, Convolutional Neural Network, Artificial Neural Network.

## 1. INTRODUCTION

Medical imaging, which provides unique therapeutic and increasingly diagnostic capabilities that have an effect on patient care, is the cornerstone of modern healthcare. Although there are many different medical imaging modalities, they all deliver anatomical and useful facts about physiopathology and structure. The multi-modality 18F-Fluorodeoxy glucose (FDG) [1] positron emission tomography and computed tomography (PET-CT) [2] scanner is acknowledged as the tomography tool of special for the diagnosis, staging, and evaluation of therapeutic reply in several cancers. Areas of abnormal function can be found using PET-CT, which combines the anatomical localization provided by CT with the sensitivity of PET. While employing PET, healthier regions frequently absorb less FDG (a marker of glucose metabolism) than sick parts do. The geographic level of the sickness inside a specific structure, however cannot be consistently resolute due to the partial volume effect, tumor heterogeneity, and the intrinsically minor resolution of PET compared to CT and MRI [3] imaging. The anatomical localization of PET image interpretation locations with aberrant FDG uptake by CT improves the accuracy of image interpretation.

Kidney cells can change and proliferate out of control, becoming renal cortical tumors, the earliest indication of kidney cancer [4]. Benign, slow-growing, or malignant tumors are all possible. Because a malignant tumour is cancerous, it has the ability to grow and spread to other parts of the body. While indolent tumors [5] can occasionally be

cancerous. In this application, we'll keep track of all the cancer-related illnesses as well as the body parts where they may be found. By comparing all of the information to prior research, we'll also recommend ways to treat cancer so that patients can utilize the recommendations to manage their conditions.

To develop this system, we would follow the following steps:

1. Scanning the patient's body and keeping the pictures.
2. To find anomalies or cancerous tissues, use PET/CT.
3. Locate the area of the body that cancer has spread to.
4. Create a model using machine learning techniques to make predictions, classify cancer types.

## 2. RELATED WORK

Our study includes prediction and classification of various cancers using images taken from a patient's body and analyzing the same. Matthias Baur and Felix Achilles [6] provide an innovative idea for crowdsourcing knowledge. Elsayed Amin Safaa Mohammed Marey [7] present a YOLO-V4 built CAD system to pinpoint any alleged breast tumorous part and, if present, to accurately categories it as benign or malignant.

Alex Roshan Welikala and Paolo Remagnino [8] collected and annotated photos of the oral cavity in addition to presenting outcomes for automating oral cancer detection at an early stage. [9] In order to identify NSCLC in PET/CT images, this study provides a multi-modality attention-guided 3D identification outline. Liu Kanfeng and Ling Chen [10] lay the groundwork for multi-modality attention-guided 3D NSCLC finding in PET/CT pictures. TaeJin Ahn and Taewan Goo [11] remarked that the best DNN model has an accuracy of 0.997 in the exercise set and 0.979 in the exam set, correctly differentiating between malignant and healthy data. Anish Simhal and Usama Chaudhary [12] described methods for retrieving color as well as texture data from VIA and VILI Cervigrammes via the processing of images. Saranya and

Sasikala [13] show that patient data are amassed in large quantities in the medical field. Long Cheng and Yuzhen Niu [14] Used an artificial neural network and the H2O framework technique, they evaluated regular blood and blood chemistry information identified 33 relevant indices as GC biomarkers. Hong-Jun Yoon and Shang Gao [15] offered a method for spreading DL NLP models among tumor databases while preserving patient privacy Zengyou Zhang And Bo Wang [16] showed how despite the fact that the ImageNet-pre-trained model can be used for transfer knowledge, the technique of identifying the prostate MR image layer by layer falls under cross-domain learning because the model created on image. [17] This research offers our multimodality attention-guided 3-D detection method for NSCLC localization in PET/CT images. Azni Nasuha Ngisa [18] said in order to detect high-risk breast cancer patients. Thosini Mudiyansele, K. Bamunu [19] showed how in today's environment, accurate cancer detection is a significant issue. Formation of novel approaches for both the detection and prognosis of cancer could be implemented. Günay Melike Zeron Orman [20] showed results according to its accuracy findings, AIS can be regarded as a preferred method

### 3. METHODOLOGY

We propose a methodology for the prediction of cancer-disease appearance based on the can be an incredibly beneficial tool to uncover hidden sights and prediction. Linear regression models [21] of machine learning technique are used for analyzing the current data with different linear regression models.

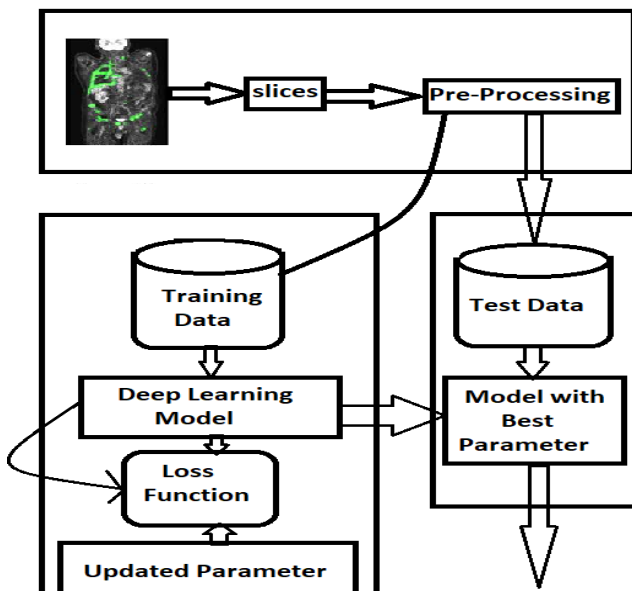

Fig 3.1. System overview

Artificial neural networks (ANNs) [22] They are then recommended as an approach of using medical pictures to discover and define cancer, such as X-rays, CT scans, and MRI scans. This can be done using techniques such as object detection, semantic segmentation. [23] for classifying malignant and benign tumors in mammograms.

#### 3.1. CLASSIFICATION

For assessing the performance of binary classification tasks including object identification, segmentation, and recognition, the F-measure [24] is a frequently used performance statistic. The F-measure, which combines accuracy and recollection, is used to assess a classifier's overall accuracy.

$$F\text{-measure} = 2 * (\text{accuracy} * \text{memory}) / (\text{accuracy} + \text{memory}) \dots (1)$$

The F-measure is particularly useful in image processing tasks, as it provides a balance between precision and recall. In object detection, for example, a high precision score is important to avoid false positives. Convolutional neural networks (CNNs) [25] is used for categorizing malignant and benign tumors in mammograms. Another example is using deep learning models for the recognition and separation of lung nodules in CT scans.

ANN are a powerful tool for detecting and localizing cancer in medical images. They can be trained to recognize specific features of cancer, and can provide accurate and automated predictions. However, the accuracy of these prediction scan varies depending on the quality and resolution of the images, as well as the specific architecture and training data used for the ANN. The Apriori method is used to reduce the computational work for the most popular approach to mining frequent patterns.

#### 3.2. SEGMENTATION

Intersection over Union (IoU) [26] is a widely used performance metric in segmentation tasks to evaluate the accuracy of a model's predictions. The connection of the anticipated segmentation mask then the actual segmentation mask. The formula for calculating the IoU is:

$$IoU = \text{connection of predicted mask and ground truth mask} / \text{union of forecast mask and ground certainty mask} \dots (2)$$
 To calculate the intersection and union of the two masks, we first need to convert the masks into binary arrays, where the background pixels are given a value of 0, the pixels corresponding to the object of interest are given a value of 1, and so on.

### 4. EXPERIMENTAL SETUP AND EXPECTED RESULTS

The system is developed in Python using generic code to coordinate with the utilities of the system. The system will be supported with VRAM: 12GB NVIDIA RTX A6000, video card GeForce RTX 3080 and graphics card AMD Radon RX580. The data set required is downloaded from Kaggle.

The traditional F measure is designed as follows:

$$F\text{-Measure} = (2 * \text{Accuracy} * \text{Memory}) / (\text{Accuracy} + \text{Memory}) \dots (3)$$

We can first define the true positives (TP), false positives (FP), and false negatives (FN) as follows in order to simplify the equation:

The phrases for recollection and correctness are as follows:

$$\text{accuracy} = TP / (TP + FP) \dots (4)$$

$$\text{memory} = TP / (TP + FN) \dots (5)$$

Substituting these equations in the F-measure equation, we get:

$$\text{F-measure} = 2 * (TP / (TP + FP) * TP / (TP + FN)) / (TP / (TP+ FP) + TP / (TP + FN)) \dots (6)$$

Simplifying this equation, we get:

$$\text{F-measure} = 2TP / (2TP + FP + FN) \dots (7)$$

We can calculate the precision as follows:

$$\text{Precision} = \text{True Positives} / (\text{True Positives} + \text{False Positives})$$

$$\text{Precision} = 100 / (100 + 70)$$

$$\text{Precision} = 0.588$$

We can analyze the memory as follows:

$$\text{Recall} = \text{True Positives} / (\text{True Positives} + \text{False Negatives})$$

$$\text{Recall} = 100 / (100 + 15)$$

$$\text{Recall} = 0.869$$

This shows that the model has poor precision, but excellent recall.

Finally, we can analyze the F-Measure as follows:

$$\text{F-Measure} = (2 * \text{Accuracy} * \text{Memory}) / (\text{Accuracy} + \text{Memory}) \dots (8)$$

$$\text{F-Measure} = (2 * 0.588 * 0.869) / (0.588 + 0.869)$$

$$\text{F-Measure} = (2 * 0.509) / 1.454$$

$$\text{F-Measure} = 1.018 / 1.454$$

$$\text{F-Measure}=0.700$$

Cancer Types	Cancer Type Code	Precision	Recall	F-Score
Breast Cancer	1	0.588	0.869	0.700
Lung Cancer	2	0.6	0.833	0.696
Blood Cancer	3	0.562	0.9	0.690
Oral Cancer	4	0.555	0.862	0.674
Kidney Cancer	5	0.542	0.95	0.898

Table.1F-Measure Accuracy table

It is a very logical metric to use connection over union. The overlap among the expected and ground truth annotations is separated by the union of these to determine IoU.

$$J(A, B) = \frac{|A \cap B|}{|A \cup B|} \dots (a)$$

The Intersection over Union formula can be simply visualized; thus, it doesn't matter if you don't know the mathematical notation.

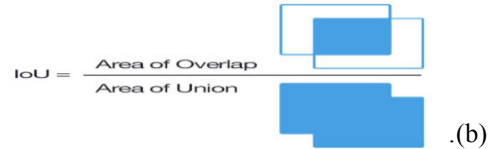

Let's train three models that predict cancer: A, B, and C. We run an image through the models using the Ground Truth that we already know (in red). Model predictions are in the Fig 1.

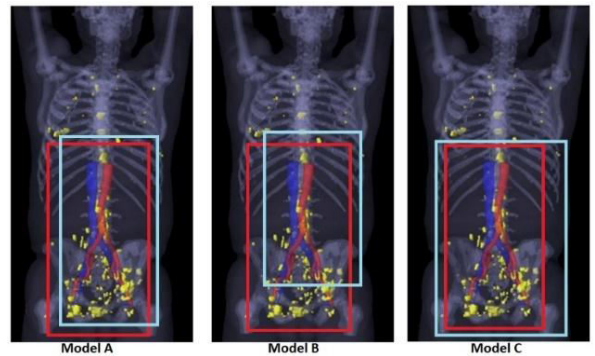

Fig1. Model indicating cancerous location

It is evident that Model A's anticipated box joins with the Ground Truth more than Model B's does. The ground truth and Model C, however, overlap much more. Yet it also overlaps with the background heavily. It is evident from models B and C that a score based just on overlap is unfair. True Positive: The region where segmentation mask and ground truth(GT) converge(S). This is logical AND operation.

$$TP=GT.S \dots (i)$$

False Positive: The anticipated region away from the truth. The segmentation minus GT logical OR is represented by this.

$$FP=(GT+S) - GT \dots (ii)$$

False Negative: The quantity of pixels in the Ground Truth region that the model was unable to forecast.

$$FN=(GT+S) - S \dots (iii)$$

IoU, as we know from Object Detection, is the proportion of the intersected area to the sum of the prediction and ground truth areas  $IoU=TP/TP+FP+FN \dots (iv)$

Fig2 by using formula ...iv will obtain like this:

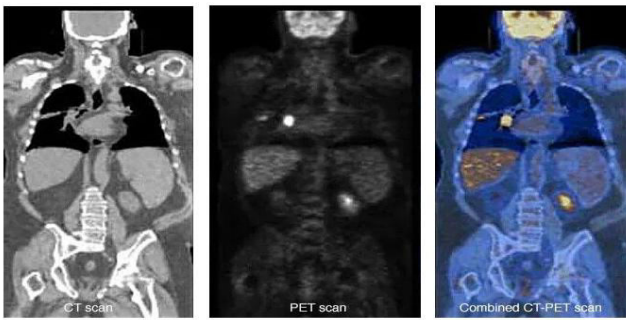

Fig2.Segmented Image

In the above session we have seen use of IOU formula for image segmentation and intersection to obtain the perfect effected area of image.

$$\text{Accuracy} = \frac{\text{Number of properly classified data points}}{\text{Total number of data points}} \dots (vi)$$

For e.g. If there are 97 classified data points properly classified and 100 data points consider for the experimentation

$$\text{accuracy} = 97/100 = 0.97 \text{ or } 97\%$$

The throughput of a system refers to the rate at which it can process a certain amount of work over a given period of time. Processing time per image = Total processing time / Number of images processed

For e.g., if the total time required for processing 200 images by a system is 10 min.

$$\begin{aligned} \text{then Total processing time per image} &= 10 \text{ minutes} / 200 \text{ images} \\ &= 0.05 \text{ minutes per image.} && \text{Throughput} = 1 / \\ \text{Processing time per image} & && \\ &= 1 / 0.05 \text{ minutes per image} \\ &= 20 \text{ images per minute} \end{aligned}$$

Comparison of Existing Systems Results with Implemented System Results				
Name of model	Accuracy Achieved by other authors	Accuracy by implemented system	Throughput Achieved by other authors	Throughput by implemented system
CNN	95%	97%	10 images/Min	20 images/Min
ANN	87%	95%	5 images/Min	10 images/Min

Table .2

Here the system increases the accuracy and throughput. Table 2 is a comparison between results achieved by previous authors and expected improved accuracy and throughput.

### 5. CONCLUSION

In the proposed study, CT and PET/CT scanners will be used for cancer detection, identification, and therapy monitoring. Depending on the visualized symptoms, the patient may choose to take precautionary steps. It is designed for the identification of many cancers, such as blood, breast, bladder, and kidney cancer.

### 6. REFERENCES

- [1] Hatt M, Visvikis D, Pradier O, Cheze-le Rest C. Baseline <sup>18</sup>F FDG PET image-derived parameters for therapy response prediction in oesophageal cancer. *Eur J Nucl Med Mol Imaging*. 2011 Sep;38(9):1595-606. doi: 10.1007/s00259-011-1834-9. Epub 2011 May 11. PMID: 21559979; PMCID: PMC3375481.
- [2] Awan MJ, Siddiqui F, Schwartz D, Yuan J, Machtay M, Yao M. Application of positron emission tomography/computed tomography in radiation treatment planning for head and neck cancers. *World J Radiol*. 2015 Nov 28;7(11):382-93. doi: 10.4329/wjr.v7.i11.382. PMID: 26644824; PMCID: PMC4663377.
- [3] G. Andria, A. M. L. Lanzolla, F. Attivissimo and T. Magli, "A new method to compare image quality in CT and MRI images," 2011 IEEE International Symposium on Medical Measurements and Applications, Bari, Italy, 2011, pp. 230-233, doi: 10.1109/MeMeA.2011.5966736.
- [4] N. Hadjiyski, "Kidney Cancer Staging: Deep Learning Neural Network Based Approach," 2020 International Conference on e-Health and Bioengineering (EHB), Iasi, Romania, 2020, pp. 1-4, doi: 10.1109/EHB50910.2020.9280188.
- [5] K. Hoyt, M. Mahoney and A. G. Sorace, "Four-dimensional molecular ultrasound imaging of tumor angiogenesis in a preclinical animal model of prostate cancer," 2014 IEEE International Ultrasonic Symposium, Chicago, IL, USA, 2014, pp. 1160-1163, doi: 10.1109/ULTSYM.2014.0285.
- [6] S. Albarqouni, C. Baur, F. Achilles, V. Belagiannis, S. Demirci and N. Navab, "AggNet: Deep Learning from Crowds for Mitosis Detection in Breast Cancer Histology Images," in *IEEE Transactions on Medical Imaging*, vol. 35, no. 5, pp. 1313-1321, May 2016, doi: 10.1109/TMI.2016.2528120.
- [7] G. Hamed, M. Marey, S. E. Amin and M. F. Tolba, "Automated Breast Cancer Detection and Classification in Full Field Digital Mammograms Using Two Full and Cropped Detection Paths Approach," in *IEEE Access*, vol. 9, pp. 116898-116913, 2021, doi: 10.1109/ACCESS.2021.3105924.

- [8] R. A. Welikala et al., "Automated Detection and Classification of Oral Lesions Using Deep Learning for Early Detection of Oral Cancer," in *IEEE Access*, vol. 8, pp. 132677-132693, 2020, doi: 10.1109/ACCESS.2020.3010180.
- [9] L. Chen et al., "Multimodality Attention-Guided 3-D Detection of Nonsmall Cell Lung Cancer in 18F-FDG PET/CT Images," in *IEEE Transactions on Radiation and Plasma Medical Sciences*, vol. 6, no. 4, pp. 421-432, April 2022, doi: 10.1109/TRPMS.2021.3072064.
- [10] K. -C. Chu, M. -Y. Xiao, C. -H. Chang, C. -H. Hsiao, Y. -C. Jiang and P. -Y. Tsai, "Preliminary Study of Relationship between Health Behavior and Breast Cancer," 2019 IEEE 20th International Conference on Information Reuse and Integration for Data Science (IRI), Los Angeles, CA, USA, 2019, pp. 410-413, doi: 10.1109/IRI.2019.00069..
- [11] T. Ahn et al., "Deep Learning-based Identification of Cancer or Normal Tissue using Gene Expression Data," 2018 IEEE International Conference on Bioinformatics and Biomedicine (BIBM), Madrid, Spain, 2018, pp. 1748-1752, doi: 10.1109/BIBM.2018.8621108.
- [12] M. N. Asiedu et al., "Development of Algorithms for Automated Detection of Cervical Pre-Cancers with a Low-Cost, Point-of-Care, Pocket Colposcope," in *IEEE Transactions on Biomedical Engineering*, vol. 66, no. 8, pp. 2306-2318, Aug. 2019, doi: 10.1109/TBME.2018.2887208.
- [13] S. Saranya and S. Sasikala, "Diagnosis Using Data Mining Algorithms for Malignant Breast Cancer Cell Detection," 2020 4th International Conference on Electronics, Communication and Aerospace Technology (ICECA), Coimbatore, India, 2020, pp. 1062-1067, doi: 10.1109/ICECA49313.2020.9297481.
- [14] B. Zhang et al., "Identification Tool for Gastric Cancer Based on Integration of 33 Clinical Available Blood Indices Through Deep Learning," in *IEEE Access*, vol. 10, pp. 106081-106092, 2022, doi: 10.1109/ACCESS.2022.3172477.
- [15] M. Alawad et al., "Privacy-Preserving Deep Learning NLP Models for Cancer Registries," in *IEEE Transactions on Emerging Topics in Computing*, vol. 9, no. 3, pp. 1219-1230, 1 July-Sept. 2021, doi: 10.1109/TETC.2020.2983404.
- [16] Y. Qian, Z. Zhang and B. Wang, "ProCDet: A New Method for Prostate Cancer Detection Based on MR Images," in *IEEE Access*, vol. 9, pp. 143495-143505, 2021, doi: 10.1109/ACCESS.2021.3114733.
- [17] L. Chen et al., "Multimodality Attention-Guided 3-D Detection of Nonsmall Cell Lung Cancer in 18F-FDG PET/CT Images," in *IEEE Transactions on Radiation and Plasma Medical Sciences*, vol. 6, no. 4, pp. 421-432, April 2022, doi: 10.1109/TRPMS.2021.3072064.
- [18] A.N. Ngisa and O. H. Fang, "Identifying High-Risk Breast Cancer Patients Using Microarray and Clinical Data," 2020 IEEE International Conference on Bioinformatics and Biomedicine (BIBM), Seoul, Korea (South), 2020, pp. 2040-2044, doi: 10.1109/BIBM49941.2020.9313175.
- [19] T. K. Bamunu Mudiyansele, X. Xiao, Y. Zhang and Y. Pan, "Deep Fuzzy Neural Networks for Biomarker Selection for Accurate Cancer Detection," in *IEEE Transactions on Fuzzy Systems*, vol. 28, no. 12, pp. 3219-3228, Dec. 2020, doi: 10.1109/TFUZZ.2019.2958295.
- [20] M. Günay, Z. Orman, T. Ensari, S. Oukid and N. Benblidia, "Diagnosis of Lung Cancer Using Artificial Immune System," 2019 Scientific Meeting on Electrical-Electronics & Biomedical Engineering and Computer Science (EBBT), Istanbul, Turkey, 2019, pp. 1-4, doi: 10.1109/EBBT.2019.8742075.
- [21] Prerita, N. Sindhvani, A. Rana and A. Chaudhary, "Breast Cancer Detection using Machine Learning Algorithms," 2021 9th International Conference on Reliability, Infocom Technologies and Optimization (Trends and Future Directions) (ICRITO), Noida, India, 2021, pp. 1-5, doi: 10.1109/ICRITO51393.2021.9596295.
- [22] M. C. Irmak, M. B. H. Taş, S. Turan and A. Haşiloğlu, "Comparative Breast Cancer Detection with Artificial Neural Networks and Machine Learning Methods," 2021 29th Signal Processing and Communications Applications Conference (SIU), Istanbul, Turkey, 2021, pp. 1-4, doi: 10.1109/SIU53274.2021.9477991.
- [23] K. V. Reddy and L. R. Parvathy, "An Innovative Analysis of predicting Melanoma Skin Cancer using Mobile Net and Convolutional Neural Network Algorithm," 2022 2nd International Conference on Technological Advancements in Computational Sciences (ICTACS), Tashkent, Uzbekistan, 2022, pp. 91-95, doi: 10.1109/ICTACS56270.2022.9988569.
- [24] Lavazza, L., Morasca, S. Comparing  $\phi$  and the F-measure as performance metrics for software-related classifications. *Empire Software Eng.* 27, 185 (2022). <https://doi.org/10.1007/s10664-022-10199-2>
- [25] M. C. Younis, E. Keedwell and D. Savic, "An Investigation of Pixel-Based and Object-Based Image Classification in Remote Sensing," 2018 International Conference on Advanced Science and Engineering (ICOASE), Duhok, Iraq, 2018, pp. 449-454, doi: 10.1109/ICOASE.2018.8548845.
- [26] C. A. R. Goyzueta, J. E. C. De la Cruz and W. A. M. Machaca, "Integration of U-Net, ResU-Net and Deep Lab Architectures with Intersection Over Union metric for Cells Nuclei Image Segmentation," 2021 IEEE Engineering International Research Conference (EIRCON), Lima, Peru, 2021, pp. 1-4, doi: 10.1109/EIRCON52903.2021.9613150.

# Comparative Study for Fish-Feeding and Sustainable Growth in Aquaculture

Kanika Singh

*Electronics and Telecommunication Engineering*  
*K.J. Somaiya Institute of Technology*  
 Mumbai, India  
 kanika.singh@somaiya.edu

Deep Zaveri

*Electronics and Telecommunication Engineering*  
*K.J. Somaiya Institute of Technology*  
 Mumbai, India  
 deep.zaveri@somaiya.edu

**Abstract**—Fishes are rich in protein and other nutrients like omega-3 and vitamins. Humans can get around 50% of daily protein requirement from a 150 grams portion of fish. India produces around 14 million tonnes of fish every year. During the rearing of fish a large chunk of the feed ends up as particulates in water and pollutes it. Hence one of the challenges in aquaculture sectors is optimum fish feeding and monitoring growth of fishes. To eliminate these problems various technologies or systems have been proposed. Many different systems using Artificial Intelligence, Deep Neural Networks, Internet of Things (IoT), etc are in use to optimise and automate the feeding process. A comparison is made between different systems to understand which models can be efficient to achieve the required goals.

**Index Terms**—Fish feed optimisation, Artificial Intelligence, Image Processing, Deep Learning, Fish health monitoring.

## I. INTRODUCTION

Fishes are consumed as it is highly rich in protein and provides other nutrients like Omega-3, Vitamin B2, D, etc. Around 150 grams of fish provides 50-60% of protein a person needs in day. India produces 14.16 million tonnes of fishes annually from which around 70% are fresh water fishes. In the past 10 years the growth rate is near 8-10% per year. With this increase in consumption of fishes there comes the problem of fish feed wastage, water pollution, spread of diseases, etc if not managed properly and efficiently.

The cost of feeding the fishes is around 40-50% of the total fish farming cost. Out of the total feed dispensed, approximately 30 percentage ends up being wasted and is suspended in water. This then is decomposed using the oxygen in water, reducing the available oxygen for fishes. After decomposition it produces toxic substances like ammonia, nitrogen that can hamper the development of fishes. Hence the feed released must neither be too less, that the fishes starve and do not grow properly, nor it must be more, polluting water and harming the fishes.

As appetite of humans also changes based on the weather, i.e. in winters human normally eat more compared to summers (when the heat produced by our body needs to be reduced), the quantity of feed needed for fishes also depends on the temperature of surrounding. So the temperature of water needs to be maintained properly.

There are behavioral changes also indicating that the fishes are hungry, like aggressiveness, swimming near objects search-

ing for food. If the oxygen reduces in water then the mouth of the fishes opens and closes more frequently to take in more oxygen.

There are three categories of fish feeding - manual feeding, semi-automated feeding and fully automated feeding. In the manual feeding technique, the person has to estimate fish bodyweight per feed, waste output, feed conversion rate, and bio-energetic data at different water temperatures, etc. But this is a time consuming and resource intensive. The semi-automated feeding consists of some electronic devices like dispensers, programmed timers to dispense the feed and this method requires some human intervention. For all these parameters to be taken into consideration, it would be difficult for a less experienced person to manage and could reduce the yield and increase wastage. For a better yield the fully automated model can be advantageous where there is no human intervention which would give the optimum amount and time of feed. Computer Vision, Neural Networks etc. can be used to achieve the goal.

## II. LITERATURE SURVEY

To optimize the amount of fish feed, various methods and models have emerged in recent times. Attempts to measure the fish length have also been done. Some methods are semi-automated while some are automated processes.

The system proposed as in [3] consists of sensors and deep neural networks. The sensors used are image sensor, Dissolved Oxygen (DO) sensor, pH sensor, Oxidation Reduction Potential (ORP) sensor, Intelligent industrial sensor. The image sensor i.e. the camera used here was Sony's full HD 1080p resolution high quality Complementary Metal Oxide Semiconductor (CMOS). This camera has a wide range and can capture images through fog and it can reach a distance of 20 meters. The ORP sensor measures the oxidation-reduction rate which when higher means that the oxidation rate is higher. A DO sensor is used to measure the conductivity of water. The pH sensor is used to measure the pH of water which ideally should be between 7.5-8.5. The ORP, DO and pH sensors, overall measure the quality of water. The intelligent industrial sensor reads the inputs of the above three sensors and performs an analog or digital conversion.

This system captured videos of water splashes and ripples formed in a pond just before dispensing the feed, when the

feed is dispensed, while the fishes eat the feed and after the fishes have eaten the feed. The frames of this video were then extracted and randomly 16 consecutive frames were selected and pre-processing was carried out. This experiment was carried out for 2-3 weeks, twice a day - once at 7am and another at 5pm. The data was fed in a deep neural network model. Optimizer used here was Adam. The size of the waves help to determine whether to continue releasing the fish feed or to stop the dispenser. An accuracy of 93.2% was achieved using this model.

The proposed model in [4] is an IoT based semi-automated system. In this model, a cage is placed beneath the water surface and attached to it are sensors used to continuously capture the changes happening in the surrounding of the cage. This changes as captured by sensors and camera and the amount of leftover feed is transmitted to a remote device such as a smartphone via cloud server.

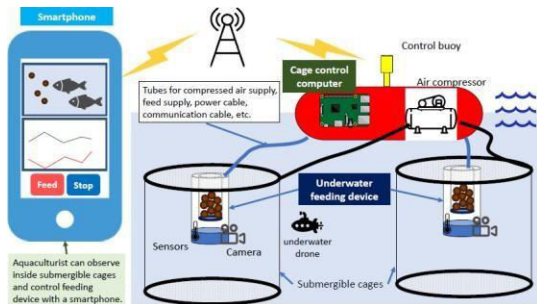

Fig. 1. IoT based feed dispenser [4]

The aquaculturists can monitor these changes and determine the optimum time to begin or end the feeding process. The cloud server on the internet receives the response and stores this response as text files. Reading these text files at regular intervals, the cage controlled by Raspberry Pi detects operations received from the smartphone for opening or closing the feeding tanks. This data can be used to train the Machine learning model for a fully automated process.

Another system for quantization of feed [6] uses artificial lighting to create a high contrast image of pellets. This was achieved by a pellet detector of 3x4 grid of 12 white LEDs. Through the detector, the contrast images were obtained and matched to a dotted blob class and calculated the sinking rate of pellets. The proposed system was implemented using c++ and OpenCV. Based on the sinking rate, the pellets were distinguished and classified across all occlusion levels.

Arduino controlled model for automatic fish system monitors the changes in the water ripple which is caused by change in fish's appetite [1]. It involves the usage of a gyroscope, Arduino Uno module and servo motor. Gyroscope sensor captures changes in angle along the X,Y and Z axis. Based on the movement of ripple produced by the gasping process of the fishes, the servo motor opens the valve for 3 seconds and releases an average of 2.48 grams of feed into the water and closes it again. The angle for slope along the X and Y axis as

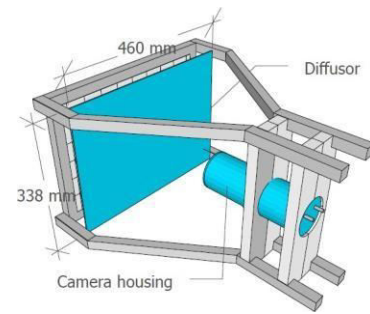

Fig. 2. Pellet Detection by Thresholding [6]

sensed by the gyroscope must be greater than  $5^\circ$  or less than  $-5^\circ$  for releasing of feed.

Since the model was in prototype form, the limitation of the model was that it could not differentiate between the ripples caused by movement of fish while searching for food and that caused while searching for oxygen.

A computer vision - based model has been developed for the estimation of length of the fishes [5]. The system design consists of three blocks. The first block which shows the input, consists of a Logitech C525 type camera which captures video in real-time. The second block - process block sends the data to load ArUco detector through a USB cable responsible for detecting the object i.e. the fish.

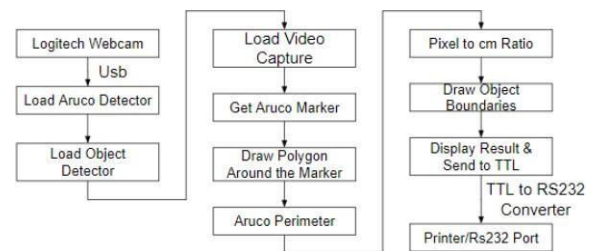

Fig. 3. Process Flow [5]

ArUco marker is an artificial square marker consisting of a black border on the outside and a binary matrix on the inside and the size of the binary matrix depends on the size of the marker. Suppose if the marker size is 3x3 then the binary matrix consists 9 bits. [5]

Following this, video gets uploaded through load video capture, which will then be assigned an ArUco maker for describing the surrounding polygons. The perimeter of the ArUco marker is measured and converted to centimeters. Once it is converted, the boundary is drawn around the fish and the measurement results are displayed through printer format or RS232 rejector.

The system achieved an accuracy of 100% in width and 99.94% in length.

The drawback of the proposed system is that if shadow is casted by the fish, due to bad light setting, then the model cannot distinguish between the fish and the shadow. The

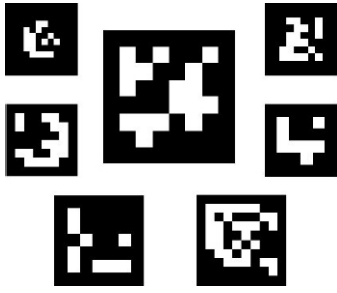

Fig. 4. ArUco Markers [5]

shadow is also included in the measurement which affects the actual measurement of the fish.

The system proposed as in [2] includes the detection of disease along with feed optimization. It focuses on food wastage and AI based disease detection in the fish pen. Their goal is to provide the farmers a system that detects the hunger of fishes and dispensers to dispense the right amount of feed at the right time. The conventional way to detect disease would need continuous attention of the farmer and close inspection of fishes. This can be time consuming and if the disease is not detected at the right time, then it would affect the health of other fishes, reducing the profit of the farmers. The solution consists of a pre-trained model that is used to identify the disease and intimate the farmer about it. It also predicts the market price of fishes for the farmers to get the best price. This is deployed on a cloud application for all the customers.

System for fish length estimation as proposed in [7] makes use of stereo cameras. The stereo camera contains two commercial IP cameras (Logitech C920). The cameras are operated by using a mini controller which receives the captured images and transmits it to the user. Power over Ethernet provides power and communication. The setup is placed in an underwater housing which helps to protect it from marine environments.



Fig. 5. Estimation of length based on the distances [7]

The model uses CNN to estimate the length of the fish by predicting fish key points. The acquired images are passed through the CNN model for predicting the key points. Then the distance between these key points is used to calculate distance between eye and snout, snout and fin, and finally between fin and tail. Based on the obtained distances the length of the fish is estimated.

This model is developed to measure the length of Gilthead seabream and European seabass species of fishes for Mediterranean aquaculture. The results obtained for the Gilthead seabream had mean relative error of 3.15% and the European seabass had mean relative error 7.14%. Weather, rapid and unpredicted fish movements due to presence of camera or personnel, husbandry operations may have led to the presence of error.

### III. COMPARISON

TABLE I  
COMPARISON OF ACCURACY AND ERROR OF MODELS

Model Type	Model Performance		
	Model	Accuracy	Error
Fish Feed	Pellet Detector [6]	98.7%	1.3%
	By water wave observation [3]	93.2%	6.8%
Fish Growth	Using ArUco marker [5]	100% (width)	0% (width)
		99.4% (length)	0.6% (length)
	Using CNN Model	96.85% (Gilthead)	3.15% (Gilthead)
		92.59% (European Seabass)	7.41% (European Seabass)

### IV. PROPOSED MODEL

From all the above systems mentioned, different technologies can be combined and a single versatile system can be made for better prediction. We have proposed a prototype that can be implemented on a fish tank. The proposed system consists of camera, pH sensor, temperature sensor, servo motor, IR sensor, LED and buzzer. Microcontroller used here is the Arduino Uno. Camera is used to capture images of the fishes; pH sensor and temperature sensor monitors the quality of water. The data is stored on the SD card through the data logger shield. Capturing of the images can be indicated by blinking of an LED.

The servo motor will control the opening and closing of the opening of feed to release the desired amount of feed into the water. IR sensor will detect the amount of feed left in the feeder and pass the signal to the buzzer when feed is low. As the prototype is implemented on a fish tank, we have connected an LED strip to provide light. It is controlled by a 5V relay. Both the servo motor and LED strip are time controlled through the RTC.

The images acquired will be passed to a classification model where each individual fish will be identified as a different class and then the fish will be extracted from the image. This fish object will then be enclosed in a bounding box and the length and width of the fish will be extracted. Using these dimensions, the growth will be monitored based on the previous weeks' data. A graph can be plotted for visualization, where the dimensions must increase as the days pass.

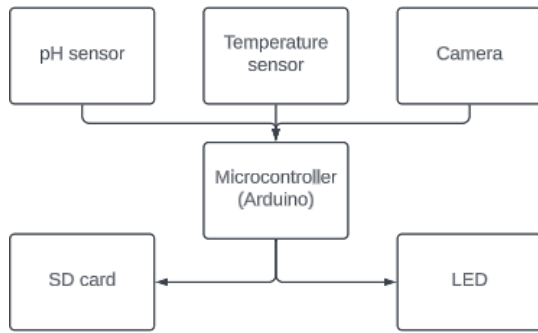

Fig. 6. Block Diagram of data collecting unit

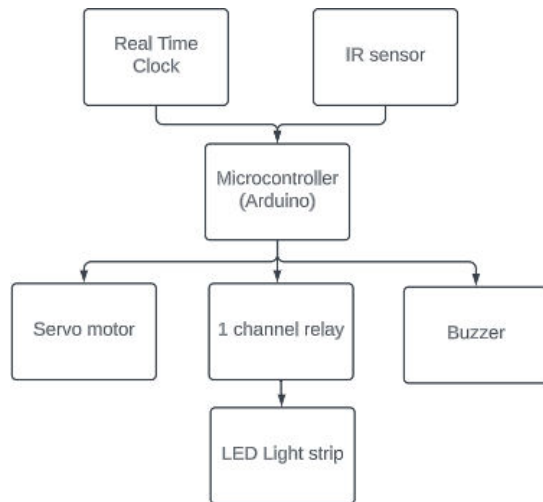

Fig. 7. Block Diagram of feeder and light automation system

## V. CONCLUSION

As the existing systems have some flaws or have limited features, there is a need for a more accurate and versatile model. We have made an attempt to propose a system which can do both, monitor the growth of fishes and optimize the quantity of feed based on the growth. There are some limitations of the proposed model.

The data is stored on an SD card. To make the system automatic, we need to send the data on a cloud server and the model used for classification should also be trained directly on the server. Also, the feeder is time controlled. We have to develop a model which can automatically control the opening and closing time of the feeder based on the growth.

So, the proposed model can be formulated using deep learning models and real time processing to eliminate the drawbacks of existing solutions explained above.

## VI. ACKNOWLEDGEMENT

We would like to thank Dr. Jayashree Khanapuri (Head of Department, Electronics and Telecommunication Department,

KJSIT) for her guidance and suggestions throughout our research.

## REFERENCES

- [1] Ratna Aisuwarya and Eddo Frans Suhendra. Development of automatic fish feeding system based on gasping behavior. In *2018 International Conference on Information Technology Systems and Innovation (ICITSI)*, pages 470–473, 2018.
- [2] Narayana Darapaneni, S Sreekanth, Anwesh Reddy Paduri, Anthony Shohan Roche, V Murugappan, Keisham Kiron Singha, and Amey V Shenwai. Ai based farm fish disease detection system to help micro and small fish farmers. In *2022 Interdisciplinary Research in Technology and Management (IRTM)*, pages 1–5, 2022.
- [3] Wu-Chih Hu, Liang-Bi Chen, Bo-Kai Huang, and Hong-Ming Lin. A computer vision-based intelligent fish feeding system using deep learning techniques for aquaculture. *IEEE Sensors Journal*, 22(7):7185–7194, 2022.
- [4] Tetsuo Imai, Kenichi Arai, and Toru Kobayashi. Smart aquaculture system: A remote feeding system with smartphones. In *2019 IEEE 23rd International Symposium on Consumer Technologies (ISCT)*, pages 93–96, 2019.
- [5] Hardi Kurnianto, Windi Puspitasari, and Ridho Hendra Yoga Perdana. A computer vision-based for fish size measurement. In *2021 International Conference on Advanced Mechatronics, Intelligent Manufacture and Industrial Automation (ICAMIMIA)*, pages 311–315, 2021.
- [6] Kristoffer Rist Skjøien, Morten Omholt Alver, and Jo Arve Alfredsen. A computer vision approach for detection and quantification of feed particles in marine fish farms. In *2014 IEEE International Conference on Image Processing (ICIP)*, pages 1648–1652, 2014.
- [7] Dimitris Voskakis, Alexandros Makris, and Nikos Papandroulakis. Deep learning based fish length estimation. an application for the mediterranean aquaculture. In *OCEANS 2021: San Diego – Porto*, pages 1–5, 2021.

# Natural Gas Price Prediction Using Random Forest Algorithm

Shruti Sanjay Anasane<sup>1</sup>

Department of Computer Science &  
Engineering  
Sipna College of Engineering &  
Technology  
Amravati, India.  
shrutianasane461@gmail.com

Sanskriti Rajendra Khadse<sup>2</sup>

Department of Computer Science &  
Engineering  
Sipna College of Engineering &  
Technology  
Amravati, India.  
sanskritikhadse112@gmail.com

Prof. Ravina Popli<sup>3</sup>

Department of Computer Science &  
Engineering  
Sipna College of Engineering &  
Technology  
Amravati, India.  
ravinapopli2430@gmail.com

**Abstract**— The natural gas market is highly dynamic and affected by various factors such as supply and demand, weather conditions, geopolitical events, and economic trends. Accurate prediction of natural gas prices is crucial for market participants, including energy companies, investors, and policymakers, to make informed decisions and manage risks effectively. In this context, this paper presents a natural gas price prediction system that utilizes machine learning techniques to forecast natural gas prices.

The proposed system employs a multi-step approach that involves data collection, preprocessing, model training and building, and model testing. Historical natural gas price data, along with relevant external factors such as weather data, economic indicators, and geopolitical events, are collected and preprocessed to create a comprehensive dataset.

The results of the experiments demonstrate that the proposed natural gas price prediction system is capable of accurately forecasting natural gas prices by using random forest algorithm. The system provides valuable insights and forecasts that can aid market participants in making informed decisions related to natural gas trading, risk management, and investment strategies.

Overall, the proposed natural gas price prediction system contributes to the field of energy economics and finance by providing a robust and effective tool for forecasting natural gas prices, which can help market participants navigate the complex and volatile natural gas market with greater confidence and improved decision-making.

**Keywords**— Natural Gas, Forecasting, Random Forest

## I. INTRODUCTION

The natural gas market plays a significant role in the global energy landscape, serving as a crucial source of energy for various industrial, commercial, and residential sectors. Natural gas prices are subject to frequent fluctuations due to various factors such as changes in supply and demand dynamics, weather conditions, geopolitical events, and economic trends. Accurate prediction of natural gas prices is vital for market participants, including energy companies, investors, and policymakers, to effectively manage risks, optimize trading strategies, and make informed decisions.

Over the years, there has been growing interest in developing predictive models using machine learning techniques to forecast natural gas prices. Machine learning

algorithms have the potential to capture complex patterns and relationships in large datasets, enabling the creation of accurate prediction models. These models can consider a wide range of factors that influence natural gas prices, including historical price data, weather conditions, economic indicators, and geopolitical events, among others.

In this context, this paper presents a natural gas price prediction system that utilizes machine learning algorithm to forecast natural gas prices. The system adopts a multi-step approach involving data collection, preprocessing, model training and building, and model testing. It leverages historical natural gas price data, along with relevant external factors, to create a comprehensive dataset. The machine learning model is trained on the preprocessed dataset.

## II. LITERATURE SURVEY

Natural gas price prediction has been a topic of extensive research in the field of energy economics and finance. Various methodologies have been proposed to forecast natural gas prices, ranging from traditional time-series models to more advanced machine learning techniques. The literature survey highlights the key findings and contributions of previous research in this area, as well as the gaps that the proposed natural gas price prediction system aims to address.

### Time-Series Models:

Time-series models have been widely used for natural gas price prediction due to their ability to capture temporal patterns and trends. Autoregressive Integrated Moving Average (ARIMA) models have been commonly employed in natural gas price forecasting [1]. However, ARIMA models may have limitations in capturing complex nonlinear relationships and may not perform well with large and complex datasets.

Seasonal ARIMA (SARIMA) models, which incorporate seasonal components, have also been used in natural gas price prediction [2]. SARIMA models can capture seasonal patterns and provide better accuracy for longer forecast horizons compared to ARIMA models. However, they may still struggle with capturing nonlinear patterns and incorporating multiple external factors.

### Machine Learning Techniques:

In recent years, machine learning techniques have gained popularity for natural gas price prediction due to their ability to capture complex patterns in large datasets. Support Vector Machines (SVM), Artificial Neural Networks (ANN), and Decision Trees have been applied in natural gas price forecasting [3].

Deep learning techniques, such as Long Short-Term Memory (LSTM) and Convolutional Neural Networks (CNN), have also been utilized for natural gas price prediction. LSTM models, which are a type of recurrent neural network, have been shown to effectively capture long-term dependencies and nonlinear patterns in time-series data [4]. Ensemble models, such as Random Forest and Gradient Boosting, have been used to combine the strengths of multiple models for natural gas price prediction [5].

### Integration of External Factors:

Many studies have highlighted the importance of incorporating external factors, such as weather conditions, economic indicators, and geopolitical events, into natural gas price prediction models. For example, weather conditions, such as temperature and heating degree days, have a significant impact on natural gas demand and prices. Economic indicators, such as GDP, inflation, and industrial production, can influence natural gas consumption and prices. Geopolitical events, such as supply disruptions or changes in trade policies, can also affect natural gas markets. Some studies have integrated external factors into time-series models as exogenous variables, while others have used machine learning techniques to capture the relationships between natural gas prices and external factors [6].

Overall, the literature suggests that there is no versatile solution for natural gas price prediction. The most efficient method will depend on various factors, such as the available data, the specific market being analyzed, and the desired level of accuracy.

## III. METHODOLOGY

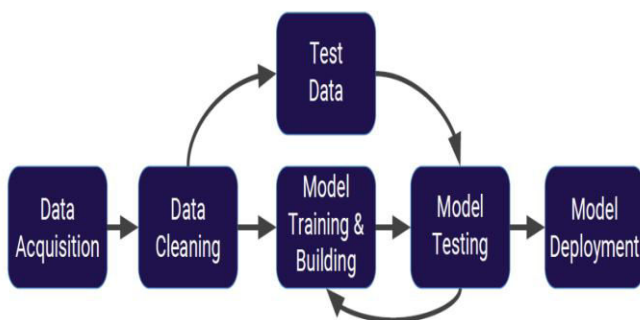

Fig. 1. Flow Diagram

### *A. Data Collection*

The collection of data is one of the major and crucial tasks of any machine learning project. Since the input we feed to the algorithms is data. So, the algorithm's effectiveness and delicacy depend upon the correctness and quality of the data collected. Hence as the data same will be the output.

### *B. Data Pre-processing*

Collecting the data is the first task and making that data useful is another important task. Data collected from multiple sources will be in an unstructured format and there may be a lot of null values, invalid data values, and unwanted data values. Cleaning all these data values and replacing them with appropriate or approximate data values and removing null, missing data values, and replacing them with some fixed alternate values are the basic steps in pre-processing the data. Indeed, the data collected may contain entirely scrap or garbage values. It may not be in the accurate format or way that is meant to be. All similar cases must be verified and replaced with equivalent values to make data meaningful and useful for further processing. Data must be kept in a structured format.

### *C. Application of Algorithm*

The next step involves applying a machine learning algorithm (random forest algorithm) to the data and observing the corresponding results. Random forest is an ensemble method that constructs multiple decision trees and produces a class that is the mode of the classes or the mean prediction of the individual trees. The random forest algorithm works by randomly selecting a subset of the features from the input dataset and building a decision tree for each subset. Each decision tree is built by recursively splitting the data based on the selected features until a certain condition is met such as a maximum tree depth, the minimum number of samples in each leaf node, or other user-defined criteria. During the prediction phase, the input data is passed through each decision tree and the output from each tree is averaged or counted to produce a final prediction. The random selection of features and the use of multiple trees helps to reduce overfitting and increase the accuracy of the model.

### *D. Training and Testing*

Finally, after processing the data and training the very next task is obviously testing. This is where the performance of the algorithm, quality of data, and required output all appear out. From the huge data set collected 70 percent of the data is utilized for training and 30 percent of the data is reserved for testing. Training is the process of making the machine learn and giving it the capability to make further predictions based on the training it took. Although testing means already having a predefined data set with output also previously labeled and the model is tested whether it is working properly or not and is giving the right prediction or

not. If the maximum number of predictions are right, then the model will have a good accuracy percentage and is reliable to continue with otherwise better to change the model.

#### IV. RANDOM FOREST ALGORITHM

The random forest algorithm produces the outcome based on the predictions of the decision trees. It predicts by taking the average or mean of the output from various decision trees. Increasing the number of decision trees increases the accuracy of the outcome.

The working of Random Forest Algorithm is explained using the following steps.

Step 1: The algorithm selects random samples from the given dataset.

Step 2: The algorithm will construct a decision tree for each sample.

Step 3: Next, the algorithm will get the prediction result from each decision tree created.

Step 4: In this step, voting will be performed for each predicted result.

Step 5: Finally, the most voted prediction result will be selected as the final prediction result.

#### V. RESULTS AND DISCUSSION

In this section, we will discuss the results that are obtained by performing the above procedure using the machine learning model. The user needs to provide a valid date as input to the random forest model through the interface and then the trained model will forecast the expected price of that day.

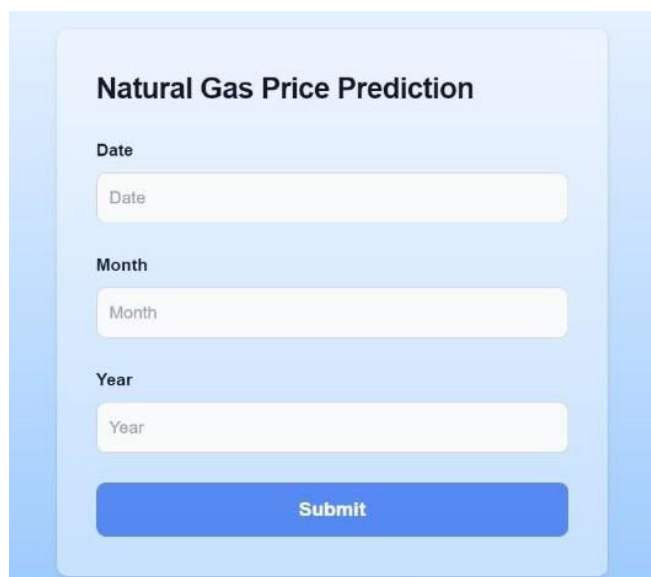

The screenshot shows a web interface titled "Natural Gas Price Prediction". It contains three input fields: "Date" (with a placeholder "Date"), "Month" (with a placeholder "Month"), and "Year" (with a placeholder "Year"). Below these fields is a blue "Submit" button.

The above figure shows the interface where the user needs to enter a particular date as input. The prediction is done using Random Forest Model.

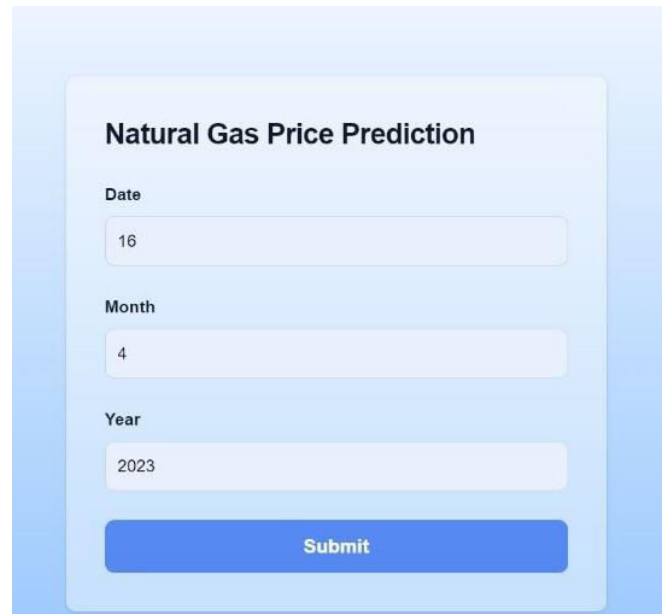

This screenshot shows the same interface as the previous one, but with the input fields filled: "Date" is "16", "Month" is "4", and "Year" is "2023". The "Submit" button is highlighted in blue.

The above figure shows that 16th April 2023 is given as input.

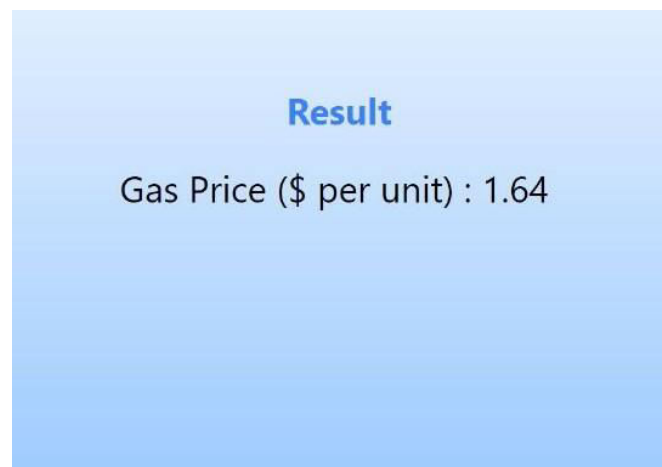

The screenshot shows a blue background with the word "Result" in bold blue text at the top. Below it, the text "Gas Price (\$ per unit) : 1.64" is displayed in a larger font.

The above figure shows the predicted price of natural gas on 16<sup>th</sup> April 2023. The prediction is done using Random Forest Model. The result of the forecast is displayed in US dollar per unit.

#### VI. LIMITATIONS

There are several limitations to natural gas price prediction that are worth noting:

Uncertainty in supply and demand: The price of natural gas is influenced by various factors, including the demand for

energy, the level of natural gas production, the availability of storage, and weather patterns. These factors are difficult to predict accurately, which can make it challenging to forecast natural gas prices.

Geopolitical risks: Natural gas is often subject to geopolitical risks, such as trade disputes, pipeline disruptions, and political instability in key producing regions. These risks can be difficult to anticipate and can significantly impact the price of natural gas.

Market volatility: The natural gas market can be highly volatile, with prices fluctuating rapidly in response to changes in supply and demand, as well as other market factors. These fluctuations can make it difficult to accurately predict future prices.

Lack of transparency: The natural gas market can be opaque, with limited information available on production levels, storage capacity, and other key factors that influence prices. This lack of transparency can make it challenging to develop accurate price forecasts.

Overall, natural gas price prediction can be challenging due to the complex and interconnected factors that influence the market, as well as the inherent uncertainty and volatility of the industry.

## VII. CONCLUSION

In this paper, the random forest algorithm is implemented to forecast the prices of natural gas. This model obtains an accuracy of 97%. The development of an accurate and reliable natural gas price prediction system has significant implications for various stakeholders in the energy industry, including natural gas producers, consumers, traders, and policymakers. Accurate price forecasts can help these stakeholders make informed decisions, optimize their operations, and manage risks associated with natural gas price fluctuations. Further research and development of the proposed natural gas price prediction system could contribute to the advancement of the field and provide valuable insights for decision-makers in the energy industry. However, challenges such as data availability, data quality, and model interpretability need to be carefully considered and addressed in the development of the system. Overall, the proposed natural gas price prediction system has the potential to improve the accuracy of natural gas price forecasts and support decision-making in the energy industry.

## VIII. FUTURE SCOPE

The future scope of natural gas price prediction systems is quite significant due to the increasing demand for natural gas as a cleaner energy source and the volatile nature of its price. Here are some potential future developments in the field of natural gas price prediction systems:

Integration of machine learning and AI techniques: With the advancement of machine learning and AI techniques, natural gas price prediction systems can become more accurate and reliable. These techniques can help in identifying patterns and trends in the market that may not be evident through traditional analysis methods.

Use of big data: Natural gas price prediction systems can benefit from the use of big data, which can include data from various sources such as weather patterns, supply and demand trends, and geopolitical events. By analyzing this data, the systems can provide more accurate price predictions.

Integration of global factors: Natural gas prices are affected by various global factors such as geopolitical events and climate change policies. Investigating the potential use of global indicators in natural gas price prediction can improve the accuracy of the models.

Overall, the future of natural gas price prediction systems is bright, and with the incorporation of new technologies and data sources, these systems can become more accurate and reliable, benefiting all stakeholders in the natural gas market.

## IX. REFERENCES

- [1] Higgs, H., Worthington, A., & Bohl, M. (2011). Forecasting natural gas prices: time-series vs. spatial models. *Energy Economics*, 33(6), 1216-1224.
- [2] Phae, P. T., Nguyen, B. K., & Ong, S. E. (2016). Short-term natural gas price forecasting with periodic time series models. *Applied Energy*, 169, 694-707.
- [3] Wang, Y., Xu, B., & Hu, L. (2018). Natural gas price forecasting using support vector machines and artificial neural networks. *Energy Economics*, 70, 360-371.
- [4] Chen, C., Hu, X., Liu, J., & Wei, Y. M. (2019). Short-term natural gas price forecasting with long short-term memory recurrent neural networks. *Applied Energy*, 236, 1272-1282.
- [5] Rahimi, S., Ghorbani, M. A., & Rashidinejad, M. (2018). Forecasting natural gas prices using ensemble methods: An empirical study in the European Union. *Energy Economics*, 75, 389-403.
- [6] Sahoo, P. K., Ghosh, S., & Maitra, D. (2020). Forecasting natural gas price using machine learning techniques: Evidence from the United States. *Applied Energy*, 263, 114659.

# Chrome Extension for Detection and Prevention of Phishing Websites and Related Attacks by Using Machine Learning and Deep Learning

Vinayak Jalan

Department of Computer Engineering  
Sinhgad Institute of Technology,  
Lonavala  
vinayakjalan.stu@gmail.com

Mrunal Pawshe

Department of Computer Engineering  
Sinhgad Institute of Technology,  
Lonavala  
mrunalpawshe4188@gmail.com

Manali Oswal

Department of Computer Engineering  
Sinhgad Institute of Technology,  
Lonavala  
manalioswal2002@gmail.com

K. S. Mulani

Department of Computer Engineering  
Sinhgad Institute of Technology,  
Lonavala  
ksm.sit@sinhgad.edu

**Abstract**— Phishing is a type of cyber-attack where a fraudulent message is sent by an attacker in order to deceive an individual into revealing sensitive information. The fraudulent message is often designed to mimic a legitimate website or organization, and the attacker can observe the victim's activity on the site. According to the FBI's Internet Crime Complaint Centre, phishing incidents have been recorded at more than twice the rate of any other type of computer crime. In 2022, phishing attacks were the most common type of attack carried out by cybercriminals. Phishing attacks peaked at an all-time high in 2021, with 300,000 attacks being registered in just one month (December), more than tripling from the previous two years. Our aim is to create a chrome extension to detect the Phishing websites and alert the user using machine learning and deep learning techniques whenever a user visits the website. The project aims to gather URLs from multiple sources, including UCI machine learning repository, Kaggle, Phish Tank, and Alexa URL. Whenever a user opens a website on his/her browser, the extension will work in the background. If the website is detected as phishing website, the user will be alerted with a pop-up box with an 'OK' button. If the website is not detected as phishing website, then no action will be taken. We have used various machine learning algorithms (Random Forest, etc.) along with deep learning algorithm (Single Layer Perceptron) to train the model and it was evaluated on the basis accuracy and on the basis of evaluation function such as recall, F1score, precision. The train/test split rule for dataset were 80/20 respectively. The browser extension was written in JavaScript. The JavaScript file extracts features of URL such as browser popup, use of frames, shortening services, etc. and then applied the algorithm to detect whether the website is legitimate or not.

**Keywords**— Phishing, Extension, URL, Random Forest, Feature extraction, Single Layer Perceptron

## I. INTRODUCTION

With the increasing use of the internet and digital platforms, the risk of online attacks such as phishing has also increased significantly. Phishing is a form of online attack where cybercriminals create fake websites or emails that mimic legitimate ones to deceive users into providing sensitive information as shown in Figure 1. This confidential

data has the potential to be exploited for illicit activities such as financial fraud or identity theft. The need to protect one from such attacks has never been more urgent, and this is where the development of our model for detection and prevention of phishing websites using machine learning comes in picture. Machine learning is a branch of artificial intelligence that allows systems to learn and enhance their performance automatically based on experience. It involves creating algorithms capable of detecting data patterns and utilizing them to make predictions. In the context of our model for detection and prevention of phishing websites, machine learning algorithms are used to identify patterns in the data associated with websites, such as their URLs, HTML tags, and text content. By utilizing these patterns, the model can discern whether a website is genuine or deceptive. Developing a model for detecting and preventing phishing websites using machine learning is crucial in today's digital landscape. Phishing attacks are becoming increasingly sophisticated, and traditional methods of detecting and preventing such attacks are no longer sufficient.

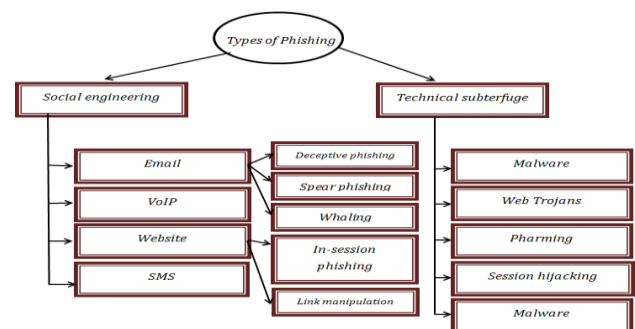

**Figure 1: Types of Phishing**

With the help of machine learning algorithms, the model can provide real-time protection against phishing attacks, allowing users to browse the internet with confidence.

## II. RELATED WORK

Mohith Gowda et al. [1], A dataset consisting of 11,055 tuples is used to train the model. These processes are carried

out on the client-side with the help of a redesigned browser architecture. For ease of access to the users they have improvised and introduced detection methods into the browser architecture named as 'Embedded Phishing Detection Browser' (EPDB), which is a novel method to preserve the existing user experience while improving its security. The system architecture for the model contains the following components User Interface, Browser Engine, Rendering Engine, Networking, UI Backend, Data Storage and the most important Intelligent Engine for detection of phishing attacks. The results shows that if the Intelligent Engine detects a Phishing Website it alerts the user with a pop-up box with two options as 'Back to Safety' and 'Continue'. Another set of result were if we compared various other classification models i.e., Logistic Regression and Support Machine Vector with the random forest classification model. The Random Forest Classification model showed an accuracy of 99.36%, with a F1 Score of 99.43%.

Patil and Dhage [2] The five approaches to anti-phishing are Rules based, Blacklisting, Content based, Machine Learning based and Hybrid. Anti-phishing tools such as Google Safe Browsing (GSB) and Netcraft, Mcfee Site Advisor, Avast and Quick Heal are used to protect against phishing websites. An effective framework for designing an anti-phishing model is presented, which involves URL gathering, feature collection, feature selection and classification. Heuristics and Hybrid approach perform best with 99.60 and 99.14% accuracy respectively.

Yang et al. [3] The paper proposes a multidimensional feature-based approach for detecting phishing, which employs a rapid deep learning detection method. The initial stage involves extracting character sequence features from the provided URL, which are then utilized for rapid categorization via deep learning. The second stage integrates various features such as statistical information about the URL, characteristics of the webpage's code, textual content of the webpage, and the outcome of the initial deep learning classification to form multi-dimensional features. The accuracy of the model reached 98.99% while the false positive rate was only 0.59%.

Xu et al. [4] This paper presents a method named "Gemini" that aims to protect users from inadvertently disclosing sensitive login information on phishing websites. It does not use appearance, but instead uses username. Prototypes of Gemini as a browser extension were implemented in Firefox, Chrome, and IE respectively. It works for pop-up login pages and searches the source of the page for elements like type="password". Gemini data can be imported and exported, and is compatible with other anti-phishing tools. In the evaluation, two sets are sent for testing: legitimate sites and the other phishing ones.

Mughaid et al. [5] This paper reviews several methodologies for detecting phishing attacks, such as PILFER, Bhat et al.'s "Beaks", and Chiew et al.'s anti-phishing tool. PILFER employs a feature set of 10 characteristics such as URL grounded and script grounded features to identify phishing attacks, while Bhat et al.'s "Beaks" employs a spam filter to classify emails as spam or non-spam. Chiew et al.'s anti-phishing tool relies on a combination of structure-based and behavior-based features, such as the sender's name, blacklisted words in the subject and content, IP address in the URL, fleck and symbol in the URL, unique sender and sphere name, hyperlink consistency, and return path. To evaluate the

effectiveness of phishing email detection, seven supervised classification algorithms were selected and utilized for training and testing purposes. The selected rate is 0.70 of the training set and 0.30 of the test, and feature selection ways need further enhancement to manage with the continuous development of new ways by the phishers.

Marchal et al. [6] Phishing is a lucrative cyber-crime that causes losses of several billion dollars every year. This paper creates an automated phishing detection system called Phish Storm which can analyze any URL in real-time to identify potential phishing sites with a correct classification rate of 94.91%. It uses the Phishing dataset and legitimate dataset to create a balanced dataset from which 12 features are selected to be used in supervised classification using random forest algorithm.

Zhu et al. [7] Phishing attack is now a big threat to people's daily life. During training dataset many useless and small influence features can cause problem of overfitting which causes inefficiency while detecting phishing websites. Based on FVV (Feature Validation Value), an algorithm is designed to select optimal features from fishing website to reduce overfitting problem and train neural network to detect phishing website. It considers various sensitive features in the start, from which, features are selected based on higher FVV. It uses Neural Network classifier with three layers for URL classification. A black and white list is first introduced to reduce time cost. For the URLs which are not in list, the neural network classifier is used to process this URL. This algorithm could properly deal with problems of big number of phishing sensitive features and the continuous change of features.

Shukla and Sharma [8] The paper designs a system using a Bayesian optimized Support Vector Machine classification approach to assign '1' if the address is secure, otherwise '0'. The system is provided with unclassified URLs and binary class output is expected. The URLs are collected, loaded, and divided into three parts: protocol, domain, and route. The results presented by the model require obtaining results with a higher level of accuracy, with a fault tolerance of 0.001%. After executing the URL function, a Bayesian optimized SVM classifier is used with a distribution of data of 40%.

Parthiban et al. [9] The proposed system introduces a new image verification process that creates a unique identity for each user. Images used for verification are encrypted using the RSA algorithm, so they cannot be used by third parties even when someone logs into the web wallet. If a single user is targeted for a phishing attack, hackers can create virtualization of custom image authentication, which requires more security in the future.

Su [10] this paper investigates heuristic detection methods such as CANTINA and CANTINA+ and visual similarity tests. The model uses the stochastic gradient descent (SGD) optimization method with an initial learning rate of 1 in 1000 and a batch size of 128. The dataset used was 2,000 legitimate websites collected by Yahoo Director and 2,000 phishing websites collected by Phish Tank. 70% of the dataset was allocated for training and the remaining 30% for testing purposes. The LSTM network employed in this study has 10 input layer nodes and one output layer node, with the aforementioned 10 features serving as the input.

### III. METHODOLOGY

The development of a model for discovery and prevention of phishing websites using machine literacy requires a well-defined methodology. The methodology outlines the way involved in creating the model, from data collection to model deployment. This section discusses the methodology used in the development of our model, as shown in Figure 2

#### Dataset

1. Abnormal URL: Checks whether URL is without hostname.
2. '@' Symbol: Checks whether URL contains '@' symbol.
3. Sub domain: Calculates the number of sub domain on the basis of dots present in URL
4. URL requests: Calculates percentage of number of times URL is requested
5. Shortening services: Checks whether the URL is too short.
6. 'HTTPS' token: Checks whether the domain has HTTPS token or not.
7. Server from handler SFH: Checks whether SFH contain "about: blank" or "Is empty"
8. URL with anchor: Calculates the percentage of anchor URL
9. Tag containing links: Calculates the percentage of links in 'Script', 'Meta' and 'link'.
10. Iframe: Checks whether webpage makes use of iframe.
11. IP Address: Checks whether URL contains IP Address.
12. Length of URL: Calculates and checks whether the length of URL is too big.
13. Double slash forwarding: Checks whether the '//' in URL is within 7th character.
14. Non-standard ports: Checks whether the port number has preferred status
15. Prefix and suffixes: Checks whether domain contains ' \_ '.
16. Favicon: Checks whether favicon is retrieved by external or internal source
17. SSL final certificate: Checks if URL is using https by trusted providers and certificate age.
18. Age of domain: Calculates the age of Domain.
19. DNS record: Checks whether the domain is with or without DNS record.
20. Links pointing to page: Calculates how many links are pointing to the Webpage.
21. Domain registration length: Checks the expiry date of Domain.

#### Data Collection

The initial step is to gather data. Data collection involves the collection of a large dataset of both legit and fraudulent websites. The dataset should be large enough to capture the variability of the different types of phishing attacks. There are various styles for collecting data, analogous as web scraping

or using being datasets. In this design, we used a dataset from Kaggle.

The link for the dataset is

<https://www.kaggle.com/code/shubha23/identification-of-phishing-websites>.

#### Data Pre-processing

Once the data has been collected, the subsequent step involves pre-processing it. Data pre-processing encompasses cleaning and transforming the data to make it ready for analysis. This step is essential because it ensures that the data is of high quality and suitable for machine literacy algorithms. The pre-processing step entails removing duplicates, managing missing values, and transforming the data into a format that is appropriate for machine learning algorithms.

The above dataset was checked for missing values, null values, duplicates and other noise using box plot and other method. From the above dataset, the features that were not very useful for detection of the phishing were dropped.

#### Model Selection

The coming step is to handpick a machine literacy model. Model selection involves choosing the swish algorithm that can directly classify legit and fraudulent websites. There exists a variety of machine learning algorithms, such as logistic regression, decision trees, and others. In this design, we used a random forest algorithm.

For this project, we trained the model using various algorithms. For each the accuracy, F1-score, precision, recall was calculated. The algorithm which provided the best values was random forest. Hence, random forest was used for training and testing the model.

We have trained and evaluated our model using 22 parameters dataset and various algorithms. From all the algorithms used Random forest provided the best accuracy. For the implementation of extension 16 parameters were used and single layer perceptron was used to detect phishing websites as random forest cannot be implemented directly in JavaScript.

#### Random Forest

Random Forest is a machine learning algorithm technique that is utilized for both classification and regression tasks. It is an ensemble method that chains multiple decision trees to make predictions. Random Forest is a powerful and versatile algorithm that is widely used in various applications, such as finance, healthcare, and marketing. Random Forest is a machine learning algorithm that creates multiple decision trees by randomly selecting subsets of the original dataset and features. This ensemble method aims to achieve better performance by combining the predictions of individual trees. This helps to reduce over fitting and increase the model's generalization ability. The ultimate prediction of the Random Forest algorithm is determined by taking into account the majority vote of all the individual trees.

#### Single Layer Perceptron:

A single-layer perceptron is a type of artificial neural network with one layer of nodes, which takes input values and produces a set of output values. The perceptron is a supervised learning algorithm used for classification tasks

where the output is a binary classification (i.e., two classes).

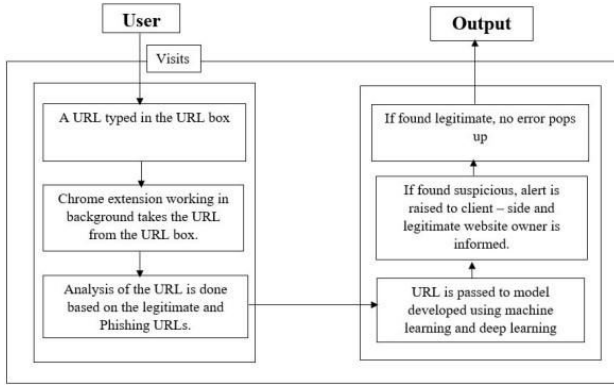

**Figure 2: Design Methodology**

The single-layer perceptron consists of one or more input nodes, a set of weights, an activation function, and an output node. Each input node is connected to the output node by a set of weights, which are adjusted during training to minimize the error in the output. The activation function used in a perceptron is a threshold function, which determines whether the output of the perceptron is 0 or 1 based on the input and the weights.

**Model Training**

After concluding the machine learning algorithm, the coming step is to train the model. Model training involves feeding the model with the pulled features and their corresponding labels. The model is trained by learning from the data and adjusting its parameters to minimize errors. According to this, data is divided into a training set and a validation set. The training set is utilized to train the model, whereas the validation set is used to assess the performance of the model. In this particular study, 80% of the data from the aforementioned dataset was employed to train the model.

**Model Evaluation**

After training the model, the coming step is to estimate its performance. To evaluate the effectiveness of the model, it is tested on a separate test set that has not been used in training. The performance of the model is then measured using various metrics such as sensitivity, accuracy, and recall. These metrics help in determining the model's capability to detect and prevent phishing attacks.

20% of data is used for testing the model.

The development of a model for discovery and prevention of phishing websites using machine literacy requires a well-defined methodology. The methodology involves collecting data, preprocessing the data, lodging applicable features, concluding a machine knowledge model, training the model, assessing its performance, and planting the model. By following this methodology, we can develop a model that provides real-time protection against phishing attacks.

**IV. IMPLEMENTATION**

The extension shows an alert to the user when a phishing website is visited to save the user from any harm. For this to work the extension needs to be added in the browser by the user. Extension is implemented using single layer perceptron

in deep learning after evaluating the accuracy of deep learning and various machine learning models.

The extension is to be first uploaded by going to the chrome://extensions sections and the on Load unpacked as mentioned in the following figure:

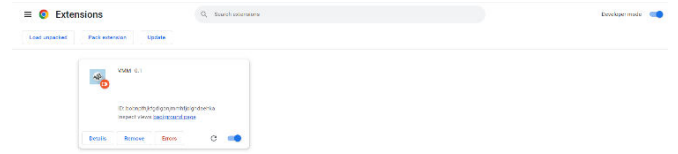

**Figure 3: Loading Extension**

The websites are detected as phishing based on various URL features. When any website is visited the URL of the website is extracted by extension, the extension then processes the URL to detect it as safe or phishing, this processing is done by JavaScript file(content.js).

If the URL is detected as phishing, then an alert is given in form of a popup to user else there is no popup. This alert is given with the use of background.js file.

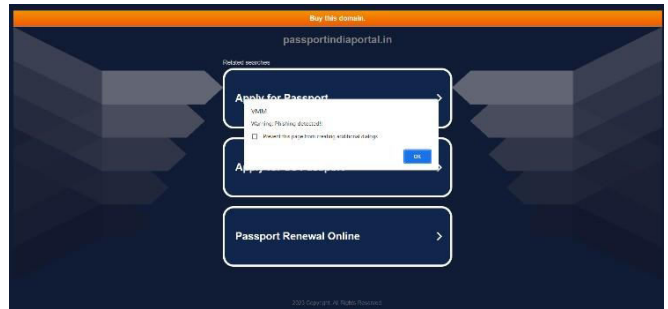

**Figure 4: Phishing alert on sample website**

After the website is detected as phishing the user is provided a form to enter the URL, source of URL and location of the user which can help to get more information about the phishing attacks and avoid future attacks.

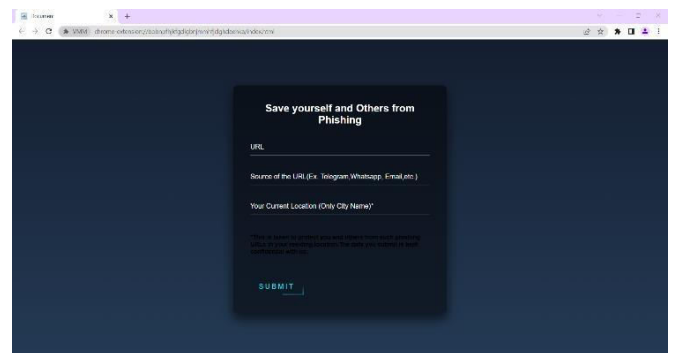

**Figure 5: Form for credentials**

The accuracies obtained by various machine learning algorithms (like Random Forest, Decision Tree, Support Vector Machines, Gradient Boosting Classifier, K-Nearest Neighbors, AdaBoost Classifier and Logistic Regression) are tabulated as follow:

Sr. No.	Classifier	Accuracy (in %)	Precision	Recall	F1-Score
1	Random Forest	96.11	0.96	0.96	0.96
2	Decision Tree	95.70	0.94	0.94	0.94
3	Support Vector Machines	94.57	0.56	1.00	0.72
4	Gradient Boosting Classifier	94.48	0.93	0.96	0.94
5	K-Nearest Neighbors	94.26	0.65	0.69	0.67
6	AdaBoost Classifier	93.48	0.92	0.96	0.94
7	Logistic Regression	93.39	0.92	0.95	0.94

**Table 1:** Metrics of various Machine Learning Algorithms

## V. CONCLUSION

In this work, we have proposed a system for detection and prevention of phishing websites. For that we have focused on URL classification of the websites. The dataset taken for this purpose contains 11055 tuples with 22 different features which has helped us to identify the website as phishing. The data present in the dataset is in the format of 1, 0, -1 which represents Legitimate, Suspicious and Phishing respectively. The Random Forest Algorithm was utilized for both training and testing of the model. The URL passed as the input to the model is first processed such that the 21 distinct features (apart from the Result i.e., is 22rd feature) are calculated in the format of 1, 0 and -1. The dataset is split into 80/20 ratio which gives us optimal data for good training and testing in order to prevent both under-fitting and overfitting of the model. The model classifies the input URL as Legitimate or Phishing with an accuracy of 96.11% having the  $n_{estimators}$  (i.e., number of trees in random forest) as 112. As a part of the future scope, we would like to notify the users related to their phishing websites; for example, if a phishing website similar to [www.microsoft.com](http://www.microsoft.com) is created; so, we would like to inform the original creator of the website regarding the phishing website that has been created. Along with that, the type of websites which showcase a fake product and take away the money can be detected using web scraping and sentimental analysis.

## VI. REFERENCES

- [1] Mohith Gowda Hr1\*, Adithya Mv2, Gunesh Prasad S3 And Vinay S4. Development of anti-phishing browser based on random forest and rule of extraction framework. Springer.
- [2] Srushti Patil, Sudhir Dhage. A Methodical Overview on Phishing Detection along with an Organized Way to Construct an Anti-Phishing Framework, 2019 5th International Conference on Advanced Computing & Communication Systems (ICACCS). 2019 IEEE. 10.1109/ICACCS.2019.8728356
- [3] Peng Yang, Guangzhen Zhao, Peng Zeng. Phishing Website Detection Based on Multidimensional Features Driven by Deep Learning. IEEE Access 2019. Digital Object Identifier 10.1109/ACCESS.2019.2892066
- [4] Zhang Xu, Haining Wang, Sushil Jajodia. Gemini: An Emergency Line of Defence against Phishing Attacks. 2014 IEEE. 10.1109/SRDS.2014.26
- [5] Ala Mughaid, Shadi AlZu'bi, Adnan Hnaif, Salah Taamneh, Asma Alnajjar, Esraa Abu Elsouid. An intelligent cyber security phishing detection system using deep learning techniques. 2022. 10.1007/s10586-022-03604-4
- [6] Samuel Marchal, Jerome Francois, Radu State, Thomas Engel. PhishStorm: Detecting Phishing with Streaming Analytics. 2014 IEEE. DOI: 10.1109/TNSM.2014.2377295
- [7] Erzhou Zhu, Yuyang Chen, Chengcheng Ye, Xuejun Li, Feng Liu. OFS-NN: An Effective Phishing Websites Detection Model Based on Optimal Feature Selection and Neural Network Volume 7. 2019. DOI: 10.1109/ACCESS.2019.2920655
- [8] Shrishti Shukla, Pratyush Sharma. Detection of Phishing URL using Bayesian Optimized SVM Classifier. 2020. DOI: 10.1109/ICECA49313.2020.9297412
- [9] R. Parthiban, V. Abarna, M. Banupriya, S. Keethana, D. Saravanan. Web folder phishing discovery and prevention with Customer image verification IEEE. 2020. DOI: 10.1109/ICSCAN49426.2020.9262395
- [10] SU Yang. Research on Website Phishing Detection Based on LSTM RNN. 2020. DOI: 10.1109/ITNEC48623.2020.9084799N
- [11] Ishita Saha, Mohammad Nazmul Alam, Dhiman Sarma, Asma Sultana, Rana Joyti Chakma, Sohrab Hossain. Phishing Attacks Detection using Deep Learning Approach. 2020. DOI: 10.1109/ICSSIT48917.2020.9214132
- [12] Fortinet: <https://www.fortinet.com>
- [13] Coursera: <https://www.coursera.org/articles/machine-learning-models>
- [14] Detection of URL based Phishing Attacks using Machine Learning – IJERT
- [15] Geeks for Geeks: <https://www.geeksforgeeks.org/data-preprocessing-in-data-mining/>
- [16] Ionut Cernica, Nirvana Popescu. Computer vision based framework for detecting phishing webpages. 2020 19th RoEduNet Conference: Networking in Education and Research (RoEduNet)
- [17] Junaid Rashid, Toqeer Mahmood, Muhammad Wasif Nisar, Tahira Nazir. Phishing Detection Using Machine Learning Technique. 2020 First International Conference of Smart Systems and Emerging Technologies (SMARTTECH)
- [18] Abdul Basit, Maham Zafar, Abdul Rehman Javed, Zunera Jalil. A Novel ensemble machine learning method to detect phishing attack. 2020 IEEE 23rd International Multitopic Conference (INMIC)
- [19] Yohanes Priyo Atmojo, Made Darma Susila, Muhammad Riza Hilmi, Erma Sulistyono Rini, Lilis Yuningsih, Dandy Pramana Hostiadi. A New Approach for Spear phishing Detection. 2021 3rd East Indonesia Conference on Computer and Information Technology (EIConCIT)
- [20] B. Janet, Yazhmozhi. V.M, Srinivasulu Reddy. Anti-phishing System using LSTM and CNN. 2020 IEEE International Conference for Innovation in Technology (INOCON)

# Learning Algorithms in Data Science

1<sup>st</sup>Aarti Verma

*MCA 1<sup>st</sup> Year, Institute of  
Technology and Science Mohan  
Nagar Ghaziabad, U.P, India.*

Delhi,India

aartiverma\_mca22\_24@its.edu.in

2<sup>nd</sup>Ujjawal Kumar

*MCA 1<sup>st</sup> Year, Institute of  
Technology and Science Mohan  
Nagar Ghaziabad, U.P, India.*

Ghaziabad,India

ujjawalkumar\_mca22\_24@its.ed  
u.in

3<sup>rd</sup> Chanchal Prabha

*Assistant Professor, Institute of  
technology and science Mohan  
Nagar Ghaziabad, U.P, India.*

Delhi, India

chanchalprabhasharma@its.edu.i  
n

**Abstract**—As the time has passed data science become an important and bigger trend. Over the year demand of data scientists is increased as it help the organization all over the world to value their results. Organization setups Business Intelligence departments and make decision from the driven data. Many machine learning algorithms have been developed to classify data and extract knowledge in a very simple way possible because manual analyzing in spreadsheet is time consuming and inefficient. In this research paper we have explained some of fundamental machine learning algorithms which every data scientist should be aware with.

**Keywords** –*Machine learning, Supervised, Unsupervised, Reinforcement, Data Science*

## 1.INTRODUCTION

An interdisciplinary subject known as data science uses scientific methods, systems, and procedures to draw conclusions and information from data. The discipline has rapidly expanded in recent years as a result of improved data accessibility and improvements in processing and storage capabilities.

In data science we deeply studies the data and then by using some method, techniques, tools and algorithm we extract meaning from the data. That data can be either in structured form or Unstructured form then that particular knowledge can be applied to Business, Government and other fields in which we can innovate new product, service, build better system or maximize profit and more.

Learning algorithms are a type of machine learning algorithm that enable computers to learn from data and improve their performance over time. They are widely used in various fields such as computer vision, natural language processing, and robotics. In this paper, we will explore the various aspects of learning algorithms and how they have transformed different industries.

Learning algorithms are a type of machine learning algorithm that enable computers to learn from data and improve their performance over time. In this paper, we will explore the intersection of learning algorithms and data science and how it has transformed different industries.

The field of artificial intelligence is heavily inspired by the brain processes and functions of humans, and machine

learning is now in a wide range of technologies that can be used for prediction.[1]

## 2.Literature Review [2]

Learning algorithms are used to extract patterns from the given data which can be either structured or unstructured. They are widely used in many fields like robotics, natural language processing, computer vision, etc. Learning algorithms can be classified into:

1. Supervised Learning
2. Unsupervised learning
3. Reinforcement learning.

**Supervised learning**consists training a model on labeled data to predict unseen data.

**Unsupervised learning** includes finding relation and patterns in unlabeled data.

**Reinforcement learning**consists training an agent to take actions in an environment for maximize rewards.

Several learning algorithms are commonly used in data science, including neural networks, decision trees, k-nearest neighbors, and support vector machines. Neural networks, in particular, have gained popularity in recent years due to their ability to learn complex patterns in data. Convolutional neural networks are commonly used in computer vision, while recurrent neural networks are used in natural language processing.

The data science process involves several steps, including problem formulation, data collection, data preparation, data analysis, and data visualization. The data analysis step can be divided into two categories: descriptive analysis and predictive analysis. Descriptive analysis involves summarizing the data to gain insights into the characteristics of the data, while predictive analysis involves building models that can predict future outcomes based on historical data.

### 3.MACHINE LEARNING ALGORITHMS[2]

Rather than being explicitly programmed, computers may learn from the data that is presented to them thanks to a subset of artificial intelligence known as machine learning. Based on the patterns that machine learning algorithms find in the input data, these algorithms are used to forecast outcomes, classify data, and carry out a variety of other activities. The strengths, drawbacks, and applications of some of the most popular machine learning algorithms are discussed in this study.

#### 3.1. Supervised Learning Algorithms:

Supervised Learning algorithms make predictions based on labeled data. These algorithms are trained on a dataset that contains input data and corresponding output data, or labels, that indicate the correct response for each input.

Supervised learning algorithms include:

- **Linear Regression:**

Linear regression is a statistical method that is used to predict a continuous variable based on a set of input variables. It assumes a linear relationship between the input variables and the output variable and uses this relationship to make predictions.

- **Logistic Regression:**

In Logistic regression, we predict the probability how an event occurred. It is commonly used in classification problems, where the goal is to predict the class of an input variable based on a set of input features.

- **Decision Trees:**

Decision trees (fig.1) are used to make decisions based on a series of branching logic. Each node in the tree represents a decision based on a specific feature of the input data, and the branches represent the possible outcomes of that decision.

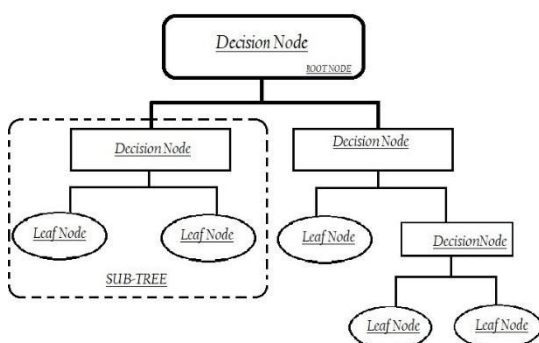

Fig.1

- **Naive Bayes:**

The Naive Bayes classification algorithm is based on the assumption that the predictors in the data set are independent. This means that the properties are unrelated. All these characteristics will lead to the probability that it is a banana in itself and not dependent on each other. The Naive Bayes algorithm is totally based on Bayes' theorem, which is the following:

$$P(A | B) = \frac{P(A) P(B | A)}{P(B)}$$

Where,

$P(A | B)$  = how often happens given that B happens  
 $P(A)$  = how likely A will happen

$P(B)$  = how likely B will happen

$P(B | A)$  = how often B happens given that A happens[2].

#### 3.2. Unsupervised Learning Algorithms:

Unsupervised Learning algorithms are used to identify patterns in data without being given any specific instructions. These algorithms are used to cluster data, reduce dimensionality, and perform other tasks that do not require labeled data.

Unsupervised learning algorithm consist:

- **K-Means Clustering:**

K-Means clustering (fig.2) is used to group data into clusters based on their similarity. It is commonly used in image segmentation, customer segmentation, and other similar applications.

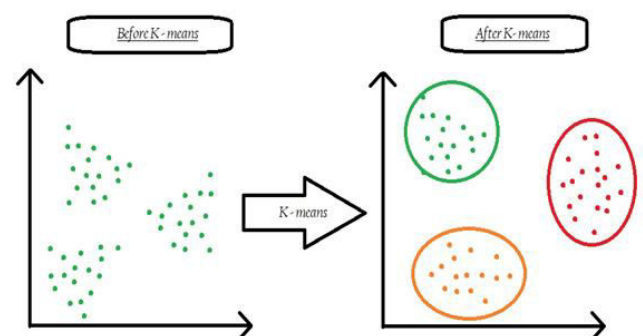

Fig.2 [2]

#### Principal Component Analysis:

Principal Component Analysis is used to reduce the dimensionality of data by identifying the most important features. It is commonly used in image and speech recognition, as well as in finance and economics.

- **Association Rule Learning:**

Association Rule Learning is used to identify patterns in data based on the frequency of their occurrence. It is generally used in market basket analysis, where the goal is to identify that which items are frequently purchased together.

### 3.3. Reinforcement Learning Algorithms:

Reinforcement Decisions based on trial and error are made using learning algorithms. These algorithms are given a target and a range of options on how to get there. By acting and getting feedback in the form of incentives or punishments, the algorithm learns.

Some commonly used reinforcement learning algorithms include:

- **Q-Learning:**

Q-Learning (fig.3) is used to learn the optimal action to take in a given state to achieve a specific goal. It uses a table to store the expected reward for each action in each state, and updates these values based on the feedback received.

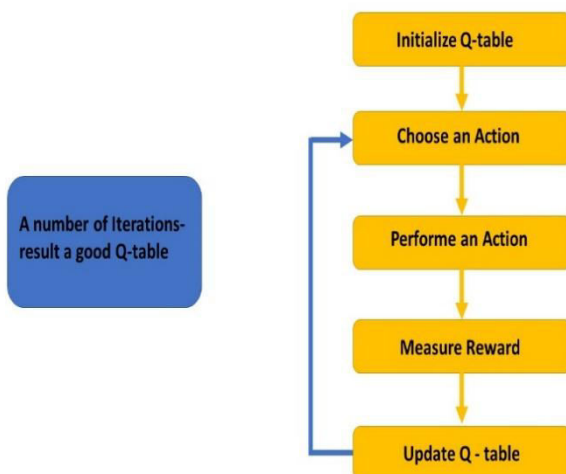

Fig.3

- **Deep Reinforcement Learning:**

Deep Reinforcement Learning uses neural networks to learn the optimal action to take in a given state. It is used in complex tasks such as playing games and controlling robots.

### 4. Applications of Machine Learning Algorithms

Machine Learning (ML) is a rapidly evolving technology that has revolutionized the way we process and analyze data. The goal of machine learning is to develop algorithms that can learn from data and make predictions, classifications, and decisions without being explicitly programmed. ML algorithms are increasingly being used across different fields, including finance, healthcare, retail, and

transportation, to name a few. In this paper, we discuss the application of Machine Learning algorithms across different fields.

#### Application of Machine Learning in Finance:

Machine learning algorithms are widely used in the finance industry for tasks such as fraud detection, portfolio optimization, and risk management. The following are some examples of how Machine Learning algorithms are applied in finance:

- **Fraud Detection:**

Machine Learning algorithms are used to identify fraudulent activities in the financial industry. These algorithms can analyze patterns in the transaction data and flag unusual activities. ML algorithms can also be used to detect identity theft, fake accounts, and credit card fraud.

- **Portfolio Optimization:**

ML algorithms can be used to optimize portfolios by analyzing past data and predicting the best possible investment strategies for future profits. For instance, ML algorithms can use predictive analytics to find correlations between different investment vehicles and develop optimal portfolio allocations.

- **Risk Management:**

Machine Learning algorithms can be used to analyze different risk factors that may affect an investment portfolio. This may include factors such as market volatility, economic trends, and geopolitical risks. ML algorithms can then use this data to make informed investment decisions.

#### Application of Machine Learning in Healthcare:

Machine Learning algorithms are widely used in healthcare for tasks such as patient diagnosis, drug discovery, and clinical trials. The following are some examples of how Machine Learning algorithms are applied in healthcare:

- **Disease Diagnosis:**

ML algorithms are used to analyze medical data and predict the likelihood of a patient developing a particular disease. For instance, Machine Learning algorithms can analyze medical images such as X-rays and CT scans to detect abnormalities and diagnose diseases such as cancer and pneumonia.

- **Drug Discovery:**

Machine Learning algorithms are used to develop new drugs and identify existing drugs that can be repurposed for new treatments. This is done by analyzing large datasets of chemical compounds and their biological activity to identify patterns and develop predictions.

- **Clinical Trials:**

Machine Learning algorithms can be used to analyze the results of clinical trials and develop personalized treatment plans for patients. This involves analyzing patient data such as genomics, medical history, and lifestyle to develop targeted treatments that are more effective and efficient.

#### **Application of Machine Learning in Retail:**

Machine Learning algorithms are used in retail for tasks such as customer segmentation, inventory management, and sales forecasting. The following are some examples of how Machine Learning algorithms are applied in retail:

- **Customer Segmentation:**

Machine Learning algorithms can be used to segment customers based on their purchasing behavior. This allows retailers to develop targeted marketing campaigns and tailor their offerings to specific customer segments.

- **Inventory Management:**

Demand forecasting and inventory level optimisation can be done using machine learning techniques. Retailers can save inventory expenses and prevent stockouts by analysing historical sales data and forecasting future demand.

- **Sales Forecasting:**

Machine Learning algorithms can be used to forecast sales based on historical data and other variables such as seasonality, weather, and economic trends. This allows retailers to plan their inventory and staffing levels to meet expected demand.

#### **Application of Machine Learning in Transportation:**

Machine Learning algorithms are used in transportation for tasks such as route optimization, autonomous driving, and predictive maintenance. The following are some examples of how Machine Learning algorithms are applied in transportation:

- **Route Optimization:**

Machine Learning algorithms can be used to optimize routes for transportation vehicles, including delivery trucks and passenger cars. This involves analyzing traffic patterns, weather conditions, and other variables to find the most efficient route.

## **5. TOOLS USED IN MACHINE LEARNING ALGORITHMS[4]**

The goal of machine learning (ML), a branch of artificial intelligence (AI), is to create algorithms that can learn from experience and get better over time without explicit

programming. The development of ML algorithms requires a wide range of tools and technologies to handle and analyze large datasets, optimize models, and deploy solutions. In this paper, we will discuss some of the commonly used tools in machine learning algorithms.

#### **Programming Languages:**

Python is one of the most widely used programming languages for developing ML algorithms. It has a large number of libraries, such as NumPy, Pandas, and SciPy, that can be used for data analysis, manipulation, and visualization. R is another popular language that is widely used for statistical analysis, data manipulation, and machine learning.

#### **Frameworks:**

Machine learning frameworks provide a set of tools and libraries that simplify the development and deployment of ML algorithms. Among the frequently used frameworks are:

- TensorFlow:**

Developed by Google, TensorFlow is a popular open-source framework used for developing ML algorithms. It provides a high-level API that simplifies the process of building and training ML models.

- PyTorch:**

PyTorch is another popular open-source framework for developing ML algorithms. It provides a dynamic computational graph that allows developers to modify and optimize models on the fly.

- Scikit-learn:**

Scikit-learn is a popular machine learning library present in Python which provides a range of algorithms for classification, regression, and clustering.

#### **Data Visualization Tools:**

Data visualization is an essential aspect of machine learning algorithms as it helps in understanding the data and identifying patterns.

Data Visualization tools Consists:

- Matplotlib:**

Matplotlib is a popular library in Python for creating visualizations such as histograms, scatter plots, and line graphs.

- Seaborn:**

Seaborn is another Python library that is used for creating statistical visualizations such as heat maps, pair plots, and violin plots.

#### **Cloud Services:**

Cloud services such as Amazon Web Services (AWS) and Microsoft Azure provide a range of services for developing, training, and deploying machine learning algorithms. These services provide scalable infrastructure, pre-built models, and APIs that can be used to develop and deploy ML solutions.

### Integrated Development Environments (IDEs):

IDEs provide an integrated environment for developing and debugging machine learning algorithms. IDEs include:

#### a. PyCharm:

PyCharm is an IDE that provides advanced debugging features and support for popular machine learning frameworks such as TensorFlow and PyTorch.

#### b. Jupyter Notebook:

An open-source web tool called Jupyter Notebook enables programmers to create and share documents with real-time code, equations, visuals, and text.

### 6. Future Scope

Machine learning and data science both are rapidly growing areas. We need data science experts in every job area and is not only limited to technology.

There can be many data science carriers as, Business intelligence developer, Data architect, Data analysts, Data scientist, Infrastructure architect and by using machine learning we can advance in field of artificial intelligence, blockchain, IoT and many more.

Data scientist helps to manage data and after analyzing the data it is easier to make decisions for our business.

With the help of data science and machine algorithm virtual reality will be friendlier.

Data science have a scope in all areas as banking, finance, communication, entertainment, e commerce, health care also have a great scope in upcoming future

### 7. Conclusion

Machine Learning Algorithm is the most important fundamental in abstract information from structured data.

Machine Learning is evolving technology that are used across different fields including finance, healthcare, retail and transportation. It helps in achieving the objective of an organization. Machine learning has reduced manual labour as it is time saving and more accurate than human being if it is program accurately. Data scientists are highly in demand as the data analyzing is the most important task for growth of any organization. Machine learning or learning algorithms in data science has opened a way for highly paid jobs.

Machine learning mainly relied on supervised learning or unsupervised learning. We need to improve our foundation of machine learning constantly and need to practice it frequently. Nowadays every person uses machine learning knowingly or unknowingly.

### 8. References

[1]N Narasimha Prasad, M. Prasad, Deepika amolAjalkar, Chanchal Prabha, Patient Monitoring System in the context of Artificial Intelligence in ICU, ., Bull. Env. Pharmacol. Life Sci., Vol 10[11] March 2022: 08-03.

[2] Vasanthy Ayyappan, Machine Learning Algorithms in Data Science, June 2021.

[3] Batta Mahesh, Machine Learning Algorithms - A Review. Volume 9, International Journal of Science and Research (IJSR) ISSN: 2319-7064 Research Gate Impact Factor (2018): 0.28 | SJIF (2018): 7.426, October 2020.

[4] Pankaj A. Nawale, Vishwas R. Wadekar, Review on Machine Learning Algorithms in Data Science, 26th and 27th February, 2022.

# Revolutionizing Indian Agriculture through Machine Learning-Based Crop Recommendation system

**Mohd Faizanuddin**

M. Tech CBIT College, OU  
Hyderabad Telangana, India

mohdfaizaan06583@gmail.com

**Afrah Fathima**

Assistant Professor, Dept. Of  
CS&IT

Maulana Azad National Urdu  
University Gachibowli,  
Hyderabad Telangana, India

Af.fathimal@gmail.com

**Mukhtar Ul Islam**

M. Tech Dept. Of CS&IT

Maulana Azad National Urdu  
University Gachibowli,  
Hyderabad Telangana, India

Mukhtar.ulislam@hotmail.com

## Abstract—

*Agriculture is an essential component of India's economy and daily life, as it provides food security and income for farmers, while also contributing to the country's overall economic growth due to the ever-increasing demand resulting from the tremendous population growth in the country. However, the major setback in Indian agriculture is that farmers often do not choose appropriate crops and instead rely on the crops their ancestors grew, without considering the impact of present-day climate and soil conditions on the crop yield. In this paper we have used various Machine Learning Models like Logistic regression, Light Gradient Boosting Machine (GBM), Support vector machine (SVM) and K nearest Neighbor (KNN) to recommend the most suitable based upon various vital input factors such as composition of nitrogen, phosphorus, and potassium in the soil as well as its pH level, humidity, and rainfall and a detailed analysis in terms of accuracy for these techniques is provided.*

**Keywords-** Agriculture, Crop Recommendation, Machine Learning, Nitrogen-Phosphorus-Potassium (NPK).

## 1. INTRODUCTION

The agriculture sector offers various outputs that cater to diverse segments such as raw materials for various industries, sources of nutrition, economic growth and business opportunities. However, the methods employed for crop cultivation are predominantly traditional and possibly outdated. Indian farmers continue to face challenges in selecting the appropriate crops. The lack of progress in the agricultural sector is the primary reason for India's economic growth falling short of expectations. This is due to mounting pressure from climate change, soil erosion, biodiversity loss, and other factors. To address these challenges, agricultural advancements are urgently needed. The success of farming ventures hinges on the selection of crops to be cultivated, which is mainly dependent on weather, soil conditions, and past crop yield data. Despite advancements in technology, the agricultural sector in India is experiencing sluggish growth. As a developing economy, agriculture is considered the backbone of India, and it is crucial to ensure agricultural sustainability. Over time, various

techniques have been developed in agriculture to enhance the living conditions of farmers. Machine learning techniques have emerged as a key tool for accurately predicting outcomes. Machine learning algorithms can be broadly categorized into three categories: supervised learning, unsupervised learning, and reinforcement learning. For our research, we employ supervised learning which establish relationships between new and old data, and derive rules that can accurately predict outcomes with the help of the labeled data.

### 1.1 Literature Survey

Rajak et al. [1] utilized a soil dataset for four types of crops. A group technique was used to classify the four crops after the dataset underwent preprocessing. The ensemble model used individual base learners. The majority voting technique was used as the combination strategy to improve accuracy. This method has the disadvantage of assuming the soil type based only on historical data, without taking into account the current soil conditions, when recommending crops.

Pudumalar et al. [2] aimed to address the problem of incorrect crop selection by farmers based on their site-specific parameters such as soil attributes, soil types, and crop yield data. They employed an ensemble model using a majority voting technique, to suggest a crop with high accuracy and efficiency. This approach helps in crop selection, ultimately increasing productivity.

Kumar et al. [3] have highlighted the issue that farmers often lack knowledge about the requirements of their crops which can lead to both psychological and economic distress. Additionally, farmers may also face challenges in detecting pests and diseases that may harm their crops. To address these issues, the authors propose a system that predicts the most suitable crop for the farmer, identifies potential pests, and suggests pest control strategies.

Gandge [4] utilized datasets containing information on various variables such as soil quality, nitrogen (N), potassium (K), phosphorous (P), and moisture levels for a given time period. The researchers employed different algorithms for different crops, including multiple linear regression for rice, K-nearest neighbor (KNN) for wheat and potato, and neural networks for corn yield prediction. However, the study did not identify a single algorithm suitable for all crops.

Yan et al. [5] examined the relationship between weather elements and wheat growth. They analyzed a set of 13 features, such as atmospheric pressure, temperature from surface meteorological data. After discretization, they narrowed down the features to three: accumulative temperature, sunshine hours, and temperature. To select the optimal farming season based on monthly data, the researchers utilized the Apriori model.

Priya et al. [6] analyzed the seasonal data and then Using MapReduce and Naïve Bayes classifier, the authors predicted the best time to sow crops for higher yield production. However, this study did not recommend which crop to sow but focused on identifying the optimal time for sowing based on the specific dataset factors.

Pawar and Chillarge [7] employed the J48 algorithm to categorize soil fertility and forecast soil toxicity. The accuracy of sensors was found to be critical to the success of the project. The objective was to evaluate the soil and suggest appropriate fertilizers to improve crop yield and water retention. However, the study did not make any crop recommendations based on profitability and yield, but rather focused on predicting soil toxicity and fertility.

Priyadharshini [8] meant to aid farmers in making the best crop choice based on factors such as sowing season, soil type, and geographical location. With the implementation of modern agricultural technologies, precision agriculture is gaining traction in developing countries, and this system aims to contribute to this trend. By providing insights that ordinary farmers might not be aware of, the proposed system aims to reduce the risk of crop failure and increase productivity, ultimately preventing farmers from incurring losses. Various machine learning models have been used to provide suitable crops with the highest accuracy being 89.88%.

Rakesh Kumar [9] created the Crop Selection Method (CSM). The CSM technique bases crop choice on the forecasted production rates, which depend on a number of variables, including weather, soil type, water density, and the type of crop. By considering variables including the crop type, sowing period, plantation duration, and anticipated yield rate for the season, the approach determines a sequence of crops that may produce the greatest amount each day over the course of the full season.

## 2 Dataset and Methodology

**2.1 Dataset**

The datasets comprises of various features which are crucial for the proper and effective growth of crops.

S.NO	Attributes	Description
1.	N	ratio of Nitrogen content in soil
2.	P	ratio of Phosphorous content in soil
3.	K	ratio of Potassium content in soil
4.	Temperature	temperature in degree Celsius
5.	Humidity	relative humidity in %
6.	ph	ph value of the soil
7.	Rainfall	rainfall in mm

**Table 1:** Data Set features for Crop Recommendation

**2.2 Step by step procedure for crop recommendation system is shown in Fig. 1**

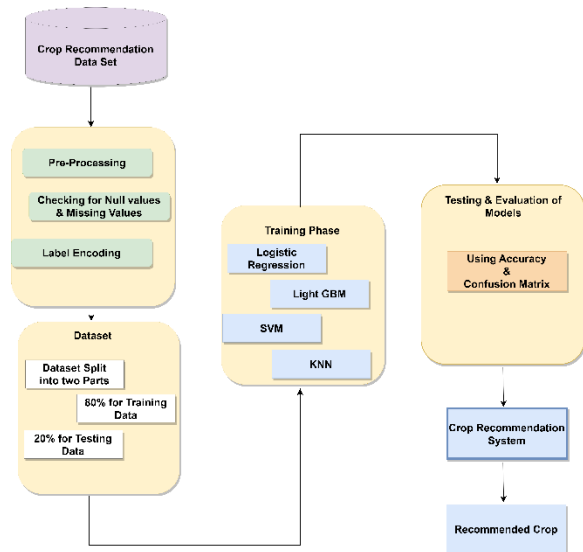

**Figure 1.** Proposed Architecture for Crop Recommendation System

**2.2.1 Dataset Collection**

The dataset used in this research paper is collected from Kaggle data repository which involves seven input attributes and this dataset is a labeled dataset. This dataset has 2200 rows and 8 columns.

```
[7] cropdf.shape
(2200, 8)
```

**Figure 2:** Size of Dataset

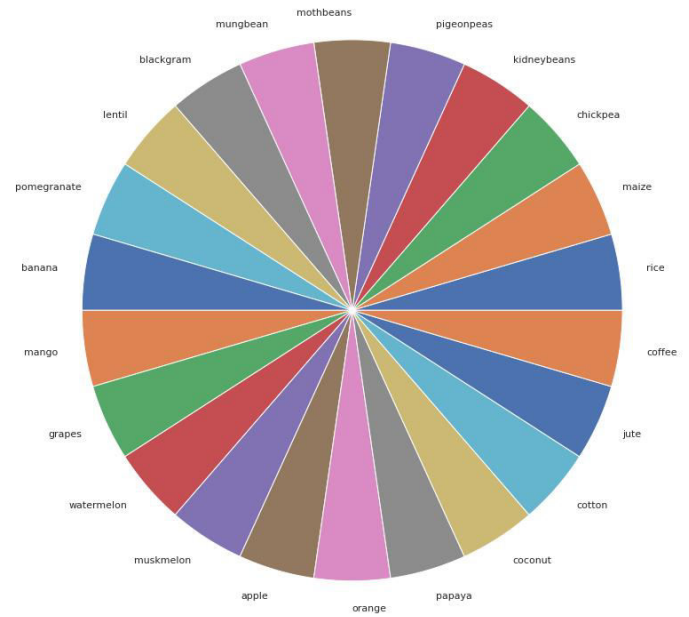

**Figure3.** Distribution of types of crops in dataset.

**2.2.2 Data Pre-processing**

In this research, data pre-processing includes checking for null values and missing values and then apply label encoding for categorical data. We have checked the null values using “isnull()” function in a pandas DataFrame, which is a popular data analysis library in python and after checking for null values we have found that there are no null values in the dataset. The missing values have been checked using “missingno” library it is built on top of Matplotlib and Seaborn libraries and provides various visualizations to identify missing data patterns in the dataset and we have found there are no missing values in the dataset. Then, we have performed label encoding which encodes the categorical data into numerical values the numerical values are assigned to each label starting from zero to (number of unique labels – 1). We have performed label encoding because many machine learning algorithms cannot handle categorical variables directly and it also helps to reduce the dimensionality of our dataset.

```
[ ] cropdf.isnull().sum()
N          0
P          0
K          0
temperature 0
humidity    0
ph          0
rainfall    0
label       0
dtype: int64
```

**Figure 4: Outcome** of examining null values.

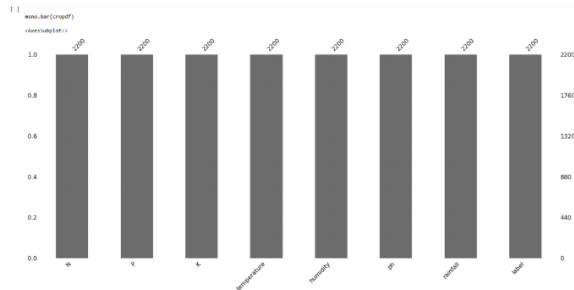

**Figure 5: A bar chart** demonstrating that the dataset has no missing values.

### 2.2.3 Data Splitting

In this step the dataset is splitted into two parts, one part is splitted into training data and the other one is testing data. We splitted the dataset into 80% for training and 20% for testing.

### 2.2.4 Training and Testing Data

The testing data is used to assess how well the trained model performed, whereas the training data is used to train the machine learning models. Testing dataset contains the data which the model has not seen before.

### 2.2.5 Methodology

we have used different Machine Learning Models like Logistic regression, Light GBM, Support vector machine and KNN which acts as a classifier to recommend the most suitable crop.

#### 2.2.5.1 Logistic Regression:

Logistic regression is a technique employed to model the association between a dependent variable and one or more independent variables. The model utilizes the logistic function, or sigmoid function, to map input values to a probability output ranging from 0 to 1. By estimating the coefficients of the independent variables, this model seeks to maximize the likelihood of the observed data. The coefficients signify the

variation in log-odds a one-unit rise in the relevant independent variable causes a one-unit increase of the dependent variable. providing valuable insights into the strength and direction of the relationship between the variables.

#### 2.2.5.2 Light GBM:

Light GBM, a gradient boosting framework, is an open-source framework that offers high performance and efficiency for handling large-scale and high-dimensional datasets. One of its unique features is the gradient-based one-sided sampling (GOSS) technique, which helps to reduce the number of samples used for gradient calculation, resulting in faster training times and improved accuracy. Light GBM also uses algorithms based on histograms, which contribute to speeding up the training process and reducing memory usage.

#### 2.2.5.3. Support Vector Machine:

The margin between the various classes, measured as the separation between the hyperplane and the nearest data points on either side, is what SVM aims to maximize. SVM divides data points into two classes because it is a binary classification technique. A regularization parameter in SVM called C manages the trade-off between correctly categorizing the training data and maximizing the margin. A high C number could cause over fitting, whilst a low C value could cause under fitting. The most efficient hyper planes are produced by employing training samples that are located on the periphery of the class distribution in a feature space.

#### 2.2.5.4. KNN

The model is considered as a lazy learner due to its approach of not explicitly learning a discriminating function from the training data. Rather, it retains the training data and applies it to predict outcomes for fresh, unobserved instances. First we need to select the k number of neighbors then for k neighbors, euclidean distance is determined.. Select the k instances with the smallest distances to the new instance as its nearest neighbors. In our model we have assigned k value as 7. Because it helps to prevent ties in the categorization decision, we have chosen an odd value for k in the KNN. There is a chance that we will have an equal number of neighbors with various class labels when we have an even number of neighbors (k).

## 3 Results

All models are tested once they have been trained by using them on the test dataset and comparing the results to the test dataset's actual labels. The models are assessed using a performance indicator named as accuracy. The model's ability to categorize the occurrences in the test dataset is demonstrated by the accuracy metric. From all the models which we have used Light GBM have shown the highest accuracy.

```
newdata=np.array([[79, 47, 39, 20.879744, 82, 6,224]])
prediction=knn.predict(newdata)
prediction
```

**Figure6.** Input for Crop Recommendation using KNN Model

```
array(['rice'], dtype=object)
```

**Figure7.** Output for the above

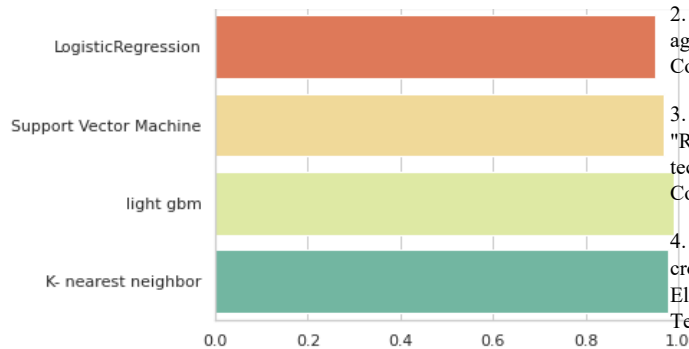

**Figure 8. Accuracy Comparison**

**Table 2. Model vs Accuracy**

Model	Accuracy (%)
Logistic Regression	95.2
Support Vector Machine	97.0
Light Gradient Boosting machine	99.0
K nearest neighbor	97.7

**4. Conclusion & Future Work**

In this research, we successfully developed and proposed an efficient crop recommendation system using Various Machine Learning Models like Logistic regression, Light Gradient Boosting Machine (GBM), Support vector machine (SVM) and K nearest Neighbor (KNN). By taking into account multiple

factors which helps crop to grow, the method assists farmers in selecting the optimal crop for their needs. This research can increase the country's productivity and generate profits using this technique. This study utilized various machine learning algorithms to recommend different crops in India. The analysis was conducted on these four algorithms, and Light GBM produced the highest accuracy results among them. The following features can be added to the system to make it even better by improving the dataset and adding more attributes is the main goal of future work and to create user-friendly website and mobile application.

**5. References**

1. Rajak, Rohit Kumar, et al. "Crop recommendation system to maximize crop yield using machine learning technique." International Research Journal of Engineering and Technology 4.12 (2017): 950-953.
2. Pudumalar, S., et al. "Crop recommendation system for precision agriculture." 2016 Eighth International Conference on Advanced Computing (ICoAC). IEEE, 2017.
3. Kumar, Avinash, Sobhangi Sarkar, and Chittaranjan Pradhan. "Recommendation system for crop identification and pest control technique in agriculture." 2019 International Conference on Communication and Signal Processing (ICCS). IEEE, 2019.
4. Gandge, Yogesh. "A study on various data mining techniques for crop yield prediction." 2017 International Conference on Electrical, Electronics, Communication, Computer, and Optimization Techniques (ICECCOT). IEEE, 2017.
5. Yan, Maoling, et al. "Research on precision management of farming season based on big data." EURASIP Journal on Wireless Communications and Networking 2018.1 (2018): 1-10.
6. Priya, Rashmi, Dharavath Ramesh, and Ekaansh Khosla. "Crop prediction on the region belts of India: a Naïve Bayes MapReduce precision agricultural model." 2018 international conference on advances in computing, communications and informatics (ICACCI). IEEE, 2018.
7. Pawar, Mayuri, and Geetha Chillarge "Soil toxicity prediction and recommendation system using data mining in precision agriculture." 2018 3rd international conference for convergence in technology (I2CT). IEEE, 2018.
8. Priyadarshini, A., et al. "Intelligent crop recommendation system using machine learning." 2021 5th international conference on computing methodologies and communication (ICCM). IEEE, 2021.
9. Kumar, et al. "Crop Selection Method to maximize crop yield rate using machine learning technique." 2015 international conference on smart technologies and management for computing, communication, controls, energy and materials (ICSTM). IEEE, 2015

# Role of Nature Inspired Algorithms in Business Analytics

*Mahak Garg*

*Student, MCA-I Year, Institute of Technology & Science, Mohan Nagar, Ghaziabad-201007*

*Gauri Sharma*

*Student, MCA-I Year, Institute of Technology & Science, Mohan Nagar, Ghaziabad-201007*

*Varun Arora*

*Assistant Professor, Department of IT, Institute of Technology & Science, Mohan Nagar, Ghaziabad-201007*

**Abstract**—Optimization is the process of finding the best solution from all feasible solutions. Metaheuristic methods are used to obtain a satisfactory solution in a reasonable time. Metaheuristic Algorithms are: Evolutionary algorithms, Swarm intelligence techniques, Physics based techniques, and Human related techniques. Some Contemporary Nature Inspired Algorithms are: Gray Wolf Optimization, Particle Swarm Optimization, Cuckoo Search, Whale Optimization Algorithm, Ant Colony Optimization. Business Analytics is the process of collecting, sorting, processing, and studying business data and using statistical models and iterative methodologies to transform data into business insights. This research paper provides information about the role of Nature Inspired Algorithms in business analytics.

**Keywords**—Business Analytics, Nature Inspired Algorithms, Gray Wolf Optimization, Particle Swarm Optimization, Cuckoo Search, Whale Optimization Algorithm, Ant Colony Optimization.

## INTRODUCTION

An optimization problem [1] is the problem of finding the best solution from all feasible solutions. Optimization problems can be divided into two categories on the basis of non-convex optimization depending on whether the variables are continuous or discrete. An optimization problem with discrete variables is known as a discrete optimization.

The optimization problem with continuous variables is known as continuous optimization. In general, optimization problems fall into one of two categories on

the basis of convex optimization: linear and nonlinear problems[2]

There are different methods for solving optimization problems. Linear fixing techniques consist of strategies like Tabu search, linear programming, and scatter search. Nonlinear solving methods include genetic algorithms. Genetic algorithms mimic the evolutionary procedures of biology via means of introducing random new solutions (called "mutations") whilst concurrently growing what seems to be a promising solution (an "organism"). By introducing random mutations, genetic algorithms are in a position to "learn" or "evolve" a higher overall, or global, answer than linear techniques.

To solve exponentially growing problems with either discrete or continuous variables, there is no exact solution that finds the best solution in a polynomial time, especially when the number of variables is large. In order to overcome this, the field of Computational Intelligence and Soft Computing techniques are useful.

They are categorized into three portions: Fuzzy logics, neural networks (or machine learning) and evolutionary computation (also known as nature inspired algorithms). Evolutionary algorithms mimic some natural phenomenon. These are further classified into three categories: Evolutionary Algorithms, Swarm Intelligence and Metaheuristic Algorithms.

There are many algorithms like Ant Colony Optimization[2], Grey Wolf Optimization Algorithm. By using these algorithms, we can tackle some serious real word problems.

Two important phases of Metaheuristic are exploration and exploitation.

Exploration indicates the ability of the algorithm to discover new search areas and exploitation focuses on finding the best solution in a promising region of the search space.

The use of metaheuristic methods has gained much more attention during the last three decades. The main target of metaheuristic methods is to obtain a satisfactory solution in a reasonable time.

These algorithms are further classified into four categories:

Evolutionary algorithms, Swarm intelligence techniques, Physics based techniques, and Human related techniques.

**A. Evolutionary algorithms [9]** are algorithms that are inspired from biology like Genetic Algorithm (GA) , and Differential Evolution(DE) etc.

**B. Physics based techniques [10]** are those techniques that are inspired by the rules governing a natural phenomenon like Gravitational Search Algorithm (GSA), Charge System Search (CSS), Central Force Optimization (CFO) etc.

**C. Human related techniques** are those techniques that are inspired from human behavior like Teaching - Learning Based Optimization (TLBO) [11] Hunting Search (HS)[7].

**D. Swarm intelligence techniques [12]** are those techniques that are inspired from the behavior of social insects or animals. Some Swarm intelligence techniques are: Ant Colony Optimization (ACO)[2][3], Particle Swarm Optimization (PSO)[4] [5], and Grey Wolf Optimization (GWO) etc.

## BUSINESS ANALYTICS

It is the aggregate of skills, technology, and practices used to study an organization's records and overall performance as a manner to benefit insights and make performance have a look at information-pushed choices with inside the destiny the usage of statistical analysis.

### TYPES OF BUSINESS ANALYTICS

#### 1. Descriptive Analytics :

It offers a clean photo of what has befallen with inside the beyond and what the cutting-edge situation is.

It takes a vital examination of your present-day country of business. It helps to realize the business's strengths and weaknesses.

#### 2. Diagnostic Analytics:

It offers an extra crucial look at the beyond and gift of enterprise. It helps to recognize why passed off and all of the motives behind it. It tells why any such aspect has taken place and is primarily based totally at the finding, the enterprise can strategize to enhance your commercial enterprise. It uses techniques such as data mining, data discovery, drill-down and correlations

#### 3. Predictive Analytics:

It offers an examination of what's going to happen.It wants statistics scientists and device mastering specialists to effectively execute the predictive analysis.

#### 4. Prescriptive Analytics:

It helps to make fashions on the way to assist to make correct predictions and make actual time adjustments to be able to supply the fine feasible outcomes.

On a good way to supply all make act additionally offers encouraged movements primarily based totally at the predicted outcomes from the business.

Nature Inspired Algorithms are helpful for correctly predicting the future results and classifications which helps the decision makers to take timely and correct decisions.

## SOME CONTEMPORARY NATURE INSPIRED ALGORITHMS

### 1. Grey Wolf Optimization (GWO)

Grey Wolf Optimization [14][17] proposed by Syed Ali Mirjalili in 2014. It is inspired by the social hierarchy and the hunting techniques of Gray wolf. Gray wolves live in highly organized packs and the pack size can be 5 to 12 wolves. They have determinant pack leaders and they are loyal to their pack members. They are the most successful animals living on the earth because of their ability to work together in a pack. As they work together in a pack, it increases their survival on the earth even in difficult situations.

#### Gray Wolf social hierarchy

Four different ranks of wolves in a pack are

**Alpha Wolf** is a pack leader, it can be a male wolf or it can be a female Wolf and all the important decisions regarding hunting, sleeping places are made by Alpha Wolf.[13]

**Beta Wolf** is the next best candidate to be Alpha wolf. It helps Alpha wolf in decision making and gives feedback to Alpha wolf.

**Delta wolf** is the third rank wolf in the hierarchy and it helps the pack in hunting and it also provides food to the pack.

**Omega wolf** is the fourth rank wolf in the wolf hierarchy. They act as a caretaker and hunter.

GWO algorithm mimics the leadership and hunting mechanism of Grey wolves. Main steps of Grey wolf hunting are:-

- Searching for the prey.
- Tracking, chasing and approaching the prey.

- Pursuing, Encircling and harassing the prey until it stops moving.
- Attacking the prey.

#### Algorithm-

The prey in the first iteration is the alpha( $\alpha$ ). It is the best solution.

Step1:- Initialize the gray wolf population

$A_i (i=1,2,\dots,n)$ .

Step2:- Initialize  $x, X$  and  $Y$ .

Step3:- Calculate the fitness of each search agent.

$A_\alpha$  = The best search agent.

$A_\beta$  = The second best search agent.

$A_\gamma$  = The third best search agent.

Step4:- While ( $t < \text{Max number of iterations}$ )

For each search agent

Update the position of the current search agent.

End for

Update  $x, X$  and  $Y$ .

Step6:- Calculate the fitness of all search agents.

Step7:- Update  $A_\alpha, A_\beta, A_\gamma$

$t = t+1$

End while.

Step8:- Return  $A_i$ .

## 2. Particle Swarm Algorithm(PSO)

Particle Swarm Optimization[4][5] is a meta-heuristic algorithm. It is popularly primarily based on a totally stochastic seek algorithm [16].

It is inspired by the social behavior of birds flocking.

PSO is a set of rules that searches for optima through updating generations. Swarm means population of moving particles and flock means move together in a crowd. This algorithm is inspired by a group of birds moving together in the crowd. It optimizes the results through enhancing a candidate solution. PSO solves problems by having a population (called swarms) of candidate solutions (particles). Population of candidate solutions that are particles.[8]

PSO plays an important role in providing robust, fast, and occasional free answers to severe complicated issues in enterprise analytics.[15]

#### Algorithm-

Step1 :- Initialization -

Initialize Parameters, Initialize Population, Initialize Position ( $A_n$ ) randomly for each particle, Initialize Velocity ( $V_n$ ) randomly for each particle.

Step2 :- Evaluate fitness.

Calculate fitness value for each particle.

If fitness value is better than best fitness value ( $gBest$ ).

Then, set a new value as new ( $gBest$ ).

Choose the particle with the pleasant health cost as  $gBest$ .

Step3 :- For each particle calculate velocity and position.

- Calculate particles position by :

$$A_n^{i+1} = A_n^i + V_n^i * i$$

- Calculate velocity by :-

$$V_n^{i+1} = W V_n^i + C_1 r_1 (A_{Best}^i - A_n^i) + C_2 r_2 (gBest_n^i - A_n^i)$$

Step4 :- Evaluate fitness  $f(A_n^i)$ .

Find current Best [ $gBest$ ].

Step5 :- Update  $i = i+1$ .

Step6 :- Output  $gBest$  and  $A_n^i$ .

## 3. Cuckoo Search Algorithm(CSA)

Cuckoo Search [6][7] Algorithm is a Metaheuristic Algorithm. CSA is inspired by some cuckoo species laying their eggs in the nest of other species of birds. They lay their eggs in the nests of individuals of other species. That increases their survival and productivity.

In this algorithm, we have two birds species Cuckoo bird and Host birds (other species).

It is a simulated walk search process. Cuckoo is searching for a suitable host nest for laying eggs. Best search strategy i.e; levy flight.[18]

Distribution is followed by cuckoo bird. Levy flight can suddenly obtain a larger step size.

Levy distribution = Series of smaller steps.

#### Algorithm-

Step1 :- Set the initial value of the host nest size  $s$ , probability  $P_{ac} \in (0,1)$  and maximum number of iteration  $Max_i$ .

Step2 :- Set  $i = 0$  {Counter initialization}.

Step3 :- For ( $n = 1 ; n \leq s$ ) do

Step4 :- Generate initial population of  $s$  host  $A_n^i$ .

Step5 :- Evaluate fitness function ( $f(A_n)$ ).

Step6 :- End for.

Step7 :- Generate a new solution (Cuckoo)  $A_n^{i+1}$  randomly by levy flight.

Step8 :- Evaluate fitness function  $A_n^{i+1}$  i.e;  $f(A_n^{i+1})$ .  
 Step9 :- Choose a nest  $A_m$  among  $s$  solutions randomly.  
 Step10 :- If  $(f(A_n^{i+1}) > f(A_m^i))$  then,  
 Step11 :- Replace the solution  $A_m$  with the solution  $A_n^{i+1}$ .  
 Step12 :- End if.  
 Step13 :- Abandon a fraction  $P_{ac}$  of the worst nest.  
 Step14 :- Build a new nest at a new location using levy flight a fraction  $P_{ac}$  of the worst nest.  
 Step15 :- Keep the best solution (nest with quality solution).  
 Step16 :- Rank the solution and find the current best solution.  
 Step17 :- Set  $i = i+1$   
 Step18 :- Until  $(i \geq \text{Max}_i)$ .  
 Step19 :- Produce the best solution.

#### 4. Whale Optimization Algorithm (WOA)

Whales are the largest mammals on Earth. We have different whale species like -Killer Whales, Finback Whales, Humpback Whales, Blue Whales, Minke Whales. There are few facts about Whales. They never sleep. They live alone or in groups[19]. Killer Whales can live in the family. Diet of Whales is Krill or Fish. Biggest Baleen Whale's length is 12 to 16 meters long and weighs 25 to 30 tons. Whale Optimization Algorithm is inspired by the hunting technique used by Humpback Whales.

##### Humpback Whales

An adult Humpback Whale is almost the size of a school bus. Humpback Whales eat Krills and small fishes. Krill is an individual who lives in the deep Ocean.

##### Humpback Whale hunting strategy :-

Whales will discover the target. Once prey is discovered, Humpback Whales dive 12 meters deep. Then, Humpback Whales create bubble nets to catch their prey. [Bubble net feeding]. Humpback Whales blow bubbles underwater, creating a net of bubbles.

##### Algorithm-

Step1 :- Initialize population for a search agent.  
 Step2 :- Calculate the fitness value for each search agent.  
 Step3 :- Choose the best search agent.  
 Step4 :- While  $(t < \text{Max}_i)$ .

Step5 :- Update  $w$ ,  $x$ ,  $X$ ,  $A$ ,  $I$  and  $p$  for each search agent.  
 Step6 :- For each search agent  
 Step7 :- If  $1(p < 0.5)$   
 Step8 :- If  $2 (|XI| > 1)$   
 Select a random agent and update position.  
 $C(i+1) = C_{\text{rand}}(i) - X * \text{Dis}$   
 Step9 :- Else if  $2 (|XI| < 1)$   
 Update position of agent.  
 Step10 :- Else if  $2 C(i+1) < w * C^*(i) - X * \text{Dis}$ ,  $p < 0.5$   
 $\text{Dis} * e^{b1} * \cos(2\pi I) + w * C^*(i)$ ,  $p \geq 0.5$   
 Step11 :- Else if  $1 (p \geq 0.5)$   
 Update position of the agent.  
 Step12 :- Calculate fitness for each search agent.  
 Step13 :- Update optimal solution.  
 Step14 :- Increment counter i.e;  $i = i+1$   
 Step15 :- Return the best search agent and its fitness value.

#### 5. Ant Colony Optimization (ACO)

Ant is a social insect that lives in colonies. There are about 13,800 ant species. The age of the queen ant is 30 years and the age of the soldier ant is 3 years. They live in colonies. An average ant colony contains thousands of individual ants and a super colony contains 300 million ants.

Ants do not have ears, they only feel vibrations. They communicate using Pheromones, sound and touch[3]. Ant Colony Optimization [2] algorithm is a metaheuristic algorithm inspired by the social behavior of real ants. ACO is basically inspired by the pheromone based Ant communication. ACO was developed by Macro Dorigo in 1992. This technique is used to find optimal paths. ACO is used for routing and load balancing problems.[20][21]

##### Algorithm-

Step1 :- Initialize ACO parameters.  
 Step2 :- Ant solution construction.  
 Step3 :- Position each ant in the starting node.  
 Step4 :- Each ant will select the next node by applying a state transition rule.  
 Step5 :- Repeat until build the best solution , then compute the fitness value.  
 Step6 :- Update best solution.  
 Step7 :- Apply offline pheromone update.  
 Step8 :- Display the best result.

#### References

- [1] Haruna Chiroma<sup>1</sup>, Abdulsalam Ya'u Gital<sup>2</sup>, Nadim Rana<sup>3</sup>, Shafi'i M. Abdulhamid<sup>4</sup>, Amina N. Muhammad<sup>5</sup>, Aishatu Yahaya Umar<sup>5</sup>, d Adamu I. Abubakar<sup>6</sup>. (2019). Nature Inspired Meta-heuristic Algorithms. © Springer Nature Switzerland AG 2020, 12.
- [2] Dorigo M, Birattari M (2011) Ant colony optimization. Ency-clopedia of machine learning. Springer, Berlin
- [3] Dorigo M, Di Caro G (1999) Ant colony optimization: a new meta-heuristic. Proceedings of the 1999 congress on evolution- ary computation, CEC 99. IEEE, pp 1470-1477.
- [4] Shi Y, Eberhart RC (1999) Empirical study of particle swarm optimization. In: Proceedings of the 1999 congress on evolutionary computation, CEC 99. IEEE, pp 1945-1950
- [5] Kennedy J (2011) Particle swarm optimization. Encyclopedia of machine learning. Springer, Berlin
- [6] Yang X-S, Deb S (2014) Cuckoo search: recent advances and applications. Neural Comput Appl 24:169-174
- [7] Chiroma H, Herawan T, Fister I Jr, Fister I, Abdulkareem S, Shuib L, Hamza MF, Saadi Y, Abubakar A (2017) Bio-inspired computation: recent development on the modifications of the cuckoo search algorithm. Appl Soft Comput 61:149-173.
- [8] Karaboga D, Basturk B (2007) A powerful and efficient algorithm for numerical function optimization: artificial bee colony (ABC) algorithm. J Glob Optim 39:459-471.
- [9] Atul Thakur, Ashis Gopal Banerjee, Satyandra K Gupta. (2009, February). A survey of CAD model simplification techniques for physics-based simulation applications. ScienceDirect, 65-80.
- [10] Thomas Bartz- Beielstein, Jürgen Branke, Jörn Mehnen, Olaf Mersmann. (2014). Evolutionary Algorithms. 28.
- [11] R Venkata Rao(2016). Teaching-learning based optimization algorithm. Springer, 9-36.
- [12] Christian Blum, Xiaodong Li. (2008). Swarm intelligence in optimization. Springer, 43-85
- [13] Seyedali Mirjalili, Seyed Mohammad Mirjalili, Andrew Lewis. (2014). Gray Wolf Optimizer. ELSEVIER, 16
- [14] Zhi-jun Teng . Jin-ling Lv . Li-wen Guo. (2018). An improved hybrid gray wolf optimization algorithm. Springer, 15..
- [15] Russell C. Eberhart , Yuhui Shi. (2001). Particle Swarm Optimization: Developments, Applications and Resources. 6.
- [16] Riccardo Poli . James Kennedy . Tim Blackwell. (2007). Particle swarm optimization. Swarm Intel((2007), 25.
- [17] Nikhil Paliwal, Laxmi Srivastava, Manjaree Pandit. (2022). Application of gray wolf optimization algorithm for load frequency control in multi-source single area power systems. Springer, 22.
- [18] Amir Hossein Gandomi, Xin-She Yang, Amir Hossein Alavi. (2011). Cuckoo search algorithm: a metaheuristic approach to solve structural optimization problems. springer, 17-35.
- [19] Seyedali Mirjalili, Andrew Lewis. (2016). The Whale Optimization Algorithm. ELSEVIER, 17.
- [20] Nada M. A. Al Salami. (2009). Ant Colony Optimization Algorithm. UbiCC, 4.
- [21] Christian Blum. (2005, October). Ant colony optimization: Introduction and recent trends. ELSEVIER, 21.

# Real Time Classification and Localization of Eye Diseases using Artificial Intelligence

AnupreetaArvind Bidarkote  
Student MTech (CSE),  
Walchand Institute of Technology  
Solapur

Dr. A. M. Pujar  
Professor (CSE)  
Walchand Institute of Technology  
Solapur

**Abstract - Artificial intelligence (AI) has made significant strides recently, and as a result, a variety of novel methods for objectively evaluating situations using images have been developed. Eye-related conditions are among the common health issues that afflict people. In addition to age-related macular degeneration (ARMD), cataracts, dry eye, glaucoma, and other conditions, there are other issues that might harm the eyes. Excruciating eye discomfort brought on by these conditions has the potential to lower patients' quality of life by obstructing and blurring their vision. There are many AI and image processing techniques that have been developed to aid ophthalmologists in precisely diagnosing the problem. Using a convolutional neural network, this concept automates the identification and location of ocular illnesses such as diabetic retinopathy (DR), glaucoma, cataracts, etc. The fundus pictures of the eye would be scanned and preserved for this study. With CNN, we were now able to classify or identify anomalies in the images. The abnormality would then help to pinpoint the affected region. The classification of the various eye illnesses would be the next step. The stage of the illness would then be identified. Now, we create a model that uses CNN and other artificial intelligence techniques to automatically categorize and locate eye disorders.**

**Index Terms—** ArtificialNeuralNetwork, ConvolutionalNeuralNetwork, 2DImages.

## 1. INTRODUCTION

Numerous photosensitive cells as well as other nerve cells that gather and organize visual information can be found in great quantity in the retina of the human eye. A thin tissue layer called the retina can be seen on the inner, posterior wall of your eye. Given the significance of visual perception, it is crucial to safeguard the eyes from conditions that could obstruct vision. The most frequently identified conditions that seriously impair vision are glaucoma, cataracts, and retinal disorders. One of the most prevalent causes of blindness, according to a research by the WHO [1] (World Health Organization), is the cataract (47.8%) [2]. 2) Retinal diseases (4.8%), and glaucoma (12.3%) [3]. One of these three diseases is the root cause of more than 60% of human cases of blindness. Cataracts are a disorder associated with the lens of the eye. The growth of the cloudy area in the lens is a sign of cataract formation. It will start out small and steadily grow over time, depending on the extent of the cataract, causing vision loss or blurriness. The Optic Nerve is impacted by the eye ailment glaucoma [5]. Damage to this nerve, which serves as the link

between the eye and the brain, results in vision loss.

Early glaucoma detection is essential since irreversible sight loss occurs in the later stages. The portion of the eye that is photosensitive is the retina, a nerve layer in the rear of the eye that senses light. When this area of the eye is injured, vision loss happens. It could take longer to recover vision if retina problems are not identified early on, necessitating further treatments.

To develop this system, we would follow the following steps:

1. Scan and save the fundus images [6] of the eye.
2. Use CNN [7] to classify or detect the abnormalities in the images.
3. Identify the area where the eye condition is present.
4. Generate a classification of the type of eye diseases creating a model using artificial intelligence techniques to perform prediction.

## 2. RELATED WORK

Hua Wang, Khandakar Ahmed, Hua Wang and Yanchun Zhang [8] In the proposed work, automated methods for detecting diabetic eye illness are systematically reviewed from various angles, including datasets that are currently accessible, picture preprocessing methods, deep learning models, and performance evaluation measures. Gives a thorough summary of methods for detecting diabetic eye illness, including cutting-edge field methods, with the goal of illuminating research communities, medical professionals, and diabetic patients.

Ernesto Iadanza, Francesco Goretti, Michele Sorelli, Paolo Melillo, Leandro Pecchia, Francesca Simonelli, and Monica Gherardelli [9] This concept presents a novel Clinical Decision Support System (CDSS) based on machine learning and utilizing chromatic pupillometry to help in the diagnosis of inherited retinal diseases in young children. It describes an innovative approach that starts with a look at how young people's pupils respond to chromatic light stimulation to aid clinical judgement in the diagnosis of retinitis pigmentosa.

Ayesha Kazi, Prerna Sukhija, Miloy Ajmera, and Kailas Devadkar [10] The authors suggest a method for identifying eye illnesses in which retinal blood vessels are

extracted. Deep convolutional neural networks will then be utilized to identify the presence of an exudate and classify it as either diabetic retinopathy, glaucoma, or cataract. the implementation of a system that can forecast a disease's probability and presence.

Dr. D. Selvathi, K. Suganya, [11]The suggested method studies the use of machine learning to distinguish between diabetic eye illness and other eye problems using thermography images of the eyes. Also introduced is the use of temperature variation as a diagnostic imaging technique to help ophthalmologists make clinical diagnoses of anomalies in eye structure.

SumitaWardani, Sawaluddin, PoltakSihombing [12]This study shows that the Support Vector Machine-K Nearest Neighbor hybrid outperforms the SVM alone at classifying eye issues. The accuracy of the SVM and KNN method in combination is 94.67%.

Xiong Luo, Jianyuan Li, Maojian Chen and Xi Yang, and Xiangjun Li [13]This idea proposes a deep learning-based CAD model to tackle a challenging issue in the classification of ophthalmic images through the study of retinal fundus images. On the broad introduction of related approaches on CNN, they give a deep learning-based ocular sickness detection system that incorporates a CNN with their proposed FC-loss function. Meanwhile, analysis is done on a few key technologies related to their methodology, such as CNN, loss function, and image enhancement technique CLAHE.

Vinay Nair, SavaniSuranglikar, SourabhDeshmukh, YashrajGavhane [14] The suggested computer vision model can be used to automate the identification of eye disorders on a wide scale and is capable of quickly identifying a variety of diseases.

Avigyan Sinha, Aneesh R P, Nazneen. N. S [15] The authors' deep learning approach, which uses a modified LeNet architecture, is a ground-breaking contribution to the field of ocular tumour detection. The accuracy of our technique is 98% for classifying normal photos and 95% for classifying abnormal ones. These two findings demonstrate the accuracy with which our model can distinguish between tumours and healthy tissue. This system can be successfully used in practical applications.

AbhijithNuchin, Dr. T C Manjunath, PavithraGovindaraiah[16] In the proposed study, Watershed is used to automatically identify glaucoma-affected eyes utilising image processing techniques for filtering and modification, and to implement these techniques on hardware using an FPGA.

BiswarupGanguly, Shreya Biswas, Samrat Ghosh, SabyasachiMaiti, SnehasishBodhak [17] In this idea, an automated approach for identifying eye melanoma using convolutional neural networks (CNN) is provided. A shared database is used to aggregate 170 pre-diagnosed samples, which are then pre-processed into lower

resolution samples and provided to the CNN architecture. In order to diagnose eye melanoma, the suggested approach does away with independent feature extraction and classification.

### 3. METHODOLOGY

We provide a method for categorizing and locating eye illnesses that makes use of retinal fundus images as input data, artificial intelligence [18] for data processing, and output production. The suggested approach has a layered structure similar to a conventional neural network [19]. In this instance, supervised [20] training is performed by a [21] dense network, with each layer having its own functions.

The block diagram up top demonstrates how the suggested approach actually functions. In the first CNN block, features are extracted [22], and in the other, masks are generated. The image is localized after feature extraction. It will categorize the eye data set into normal and pathological eyes using

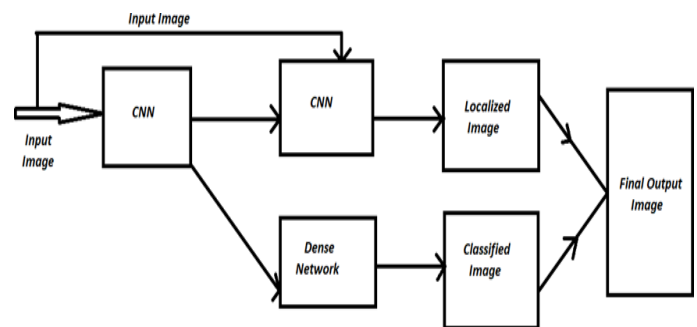

adense network.

**Fig.: Block diagram of classification and localization of eye diseases using CNN and Dense Network**

The classification of an eye as abnormal or normal depends on whether the image is localized, or whether it can pinpoint the precise location of the issue in your retina. The proposed notion will function in this manner.

Artificial Neural Network:

Artificial neural networks (ANNs) can be used to analyze optical coherence tomography (OCT) [23] images and retinal scans to detect eye issues. An extensive dataset of annotated images—where the labels indicate the presence or absence of specific eye conditions—is used to train the artificial neural network (ANN). During the testing phase, fresh images are put into the ANN, which then forecasts which diseases are present. Convolutional neural networks (CNNs), which have shown promising results in the diagnosis of a number of eye illnesses, including diabetic retinopathy, glaucoma, and age-related macular degeneration, can increase the accuracy of the predictions.

Convolutional Neural Network:

Convolutional neural networks (CNNs), a subclass of deep learning neural networks, excel at tasks involving the classification of images, such as the identification of various eye problems. In the context of identifying eye illnesses, a CNN can be trained using a substantial collection of medical images, such as retinal scans or optical coherence tomography (OCT) images. CNN develops the capacity to spot patterns in the images that could indicate different eye conditions.

During the training process, the CNN is exposed to many different examples of diseased and healthy eye images, along with the corresponding labels indicating the presence or absence of specific eye diseases. Over time, the CNN learns to distinguish between the various types of eye diseases based on the patterns present in the images.

Once trained, the CNN can be used to make predictions about brand-new, unviewed photos. The CNN analyses the image and generates a forecast of any eye disorders that might be present. The forecast is based on the recognized patterns in the training data. A number of eye disorders, such as age-related macular degeneration, glaucoma, and diabetic retinopathy, have been successfully diagnosed using CNNs.

#### 4. EXPERIMENTAL SETUP AND EXPECTED RESULTS

The system is developed in Python using generic code to coordinate with the utilities of the system. The setup consists of processor tensor core (FP16) used for processing the images. The system will be supported with VRAM: 12GB NVIDIA RTX A6000, video card GeForce RTX 3080 and graphics card

AMD Radon RX580. The data set required is downloaded from Kaggle.

The accuracy of a machine learning model is assessed by contrasting the expected and actual outputs for a set of labelled data.

Accuracy = (Number of correctly scanned images) / (Total number of images)

Accuracy =  $97 / 100 = 0.97$  or 97%

The throughput of a system refers to the rate at which it can process a certain amount of work over a given period of time.

Processing time per image = Total processing time / Number of images processed.

Throughput =  $1 / \text{Processing time per image}$

=  $1 / 0.1$  minutes per image

= 10 images per minute

#### 5. CONCLUSION

In the modern environment, ocular illness research requires more focus. For this study project, a variety of open sources are available. For our research, we picked out pictures of eye diseases from various databases. This concept described the

use of CNN and dense networks to automate the identification and localization of eye disorders. The ocular pictures undergo two stages of pre-processing: first, they are shrunk to a preset resolution, and then they are fed into the CNN architecture. Separate feature extraction, classification, and localization for eye illness detection are all done away with in the proposed study. With the same number of hidden layers, CNN's training is significantly less complicated and calls for fewer parameters than ANN. We can successfully implement this system in real-world scenarios.

#### 6. REFERENCES

- [1] Newsletter World Health Organization © 2023 WHO
- [2] A. B. Jagadale, S. S. Sonavane and D. V. Jadav, "Computer Aided System for Early Detection of Nuclear Cataract Using Circle Hough Transform," 2019 3rd International Conference on Trends in Electronics and Informatics (ICOEI), Tirunelveli, India, 2019, pp. 1009-1012, doi: 10.1109/ICOEI.2019.8862595.
- [3] J. Carrillo, L. Bautista, J. Villamizar, J. Rueda, M. Sanchez and D. Rueda, "Glaucoma Detection Using Fundus Images of The Eye," 2019 XXII Symposium on Image, Signal Processing and Artificial Vision (STSIVA), Bucaramanga, Colombia, 2019, pp. 1-4, doi: 10.1109/STSIVA.2019.8730250.
- [4] A. Nunes, A. F. Ambrosio, M. Castelo-Branco and R. Bernardes, "[Regular Paper] Texture Biomarkers of Alzheimer's Disease and Disease Progression in the Mouse Retina," 2018 IEEE 18th International Conference on Bioinformatics and Bioengineering (BIBE), Taichung, Taiwan, 2018, pp. 41-46, doi: 10.1109/BIBE.2018.00016.
- [5] A. M. Pratiwi, O. Kékesi and G. J. Suaning, "Selective neuromodulation of retinal ganglion cells via a hybrid optic-nerve and retinal neuroproteins for visual restoration," 2022 44th Annual International Conference of the IEEE Engineering in Medicine & Biology Society (EMBC), Glasgow, Scotland, United Kingdom, 2022, pp. 2381-2384, doi: 10.1109/EMBC48229.2022.9871410.
- [6] Z. Shen, H. Fu, J. Shen and L. Shao, "Modelling and Enhancing Low-Quality Retinal Fundus Images," in IEEE Transactions on Medical Imaging, vol. 40, no. 3, pp. 996-1006, March 2021, doi: 10.1109/TMI.2020.3043495.
- [7] A. Sallam et al., "Early Detection of Glaucoma using Transfer Learning from Pre-trained CNN Models," 2021 International Conference of Technology, Science and Administration (ICTSA), Taiz, Yemen, 2021, pp. 1-5, doi: 10.1109/ICTSA52017.2021.9406522.
- [8] Rubina Sarki, Khandakar Ahmed, Hua Wang and Yanchun Zhang, "Automatic Detection of Diabetic Eye Disease through Deep Learning using Fundus Images: A Survey," in IEEE Access, vol. 8, pp. 151133 - 151149, 2020.

- [9] Ernesto Iadanza, (Senior Member, IEEE), Francesco Goretti, Michele Sorelli, Paolo Melillo, (Member, IEEE), Leandro Pecchia, (Member, IEEE), Francesca Simonelli, and Monica Gherardelli, "Automatic Detection of Genetic Diseases in Pediatric Age Using Pupillometry," in IEEE Journal of Selected Topics in Applied Earth Observations and Remote Sensing, vol. 13, pp. 2169- 3536, 2020.
- [10] Ayesha Kazi, Purna Sukhija, Miloy Ajmera, Kailas Devadkar, "Processing Retinal Images to Discover Diseases", 2018 International Conference on Current Trends towards Converging Technologies (ICCTCT).
- [11] Dr. D. Selvathi (Senior Professor), K. Suganya (PG Student), "Support Vector Machine Based Method for Automatic Detection of Diabetic Eye Disease using Thermal Images", 2019 1st International Conference on Innovations in Information and Communication Technology (ICIICT)
- [12] Sumita Wardani, Sawaluddin, Poltak Sihombing, "Hybrid of Support Vector Machine Algorithm and K-Nearest Neighbor Algorithm to Optimize the Diagnosis of Eye Disease" 2020 3rd International Conference on Mechanical, Electronics, Computer, and Industrial Technology (MECnIT)
- [13] Xiong Luo Senior Member IEEE, Jianyuan Li, Maojian Chen and Xi Yang, and Xiangjun Li "Ophthalmic Disease Detection via Deep Learning with A Novel Mixture Loss Function" in 2020.
- [14] Vinay Nair, Savani Suranglikar, Sourabh Deshmukh, Yashraj Gavhane, "Multi- labelled Ocular Disease Diagnosis Enforcing Transfer Learning", 2021 55th Annual on Information
- [15] Avigyan Sinha, Aneesh R P, Nazneen. N. S, "Eye Tumors Detection using Deep Learning", 2021 Seventh International conference on Bio Signals, Images, and Instrumentation (ICBSII).
- [16] Abhijith Nuchin, Dr. T C Manjunath, Pavithra Govindarajah, "FPGA Detection of glaucoma eye disease in humans", 2018 3rd IEEE International Conference on Recent Trends in Electronics, Information and Communication Technology (RTEICT).
- [17] Biswarup Ganguly, Shreya Biswas, Samrat Ghosh, Sabyasachi Maiti, Snehasish Bodhak, "A Deep learning Framework for Eye Melanoma Detection employing Convolutional Neural Network", 2019 International Conference on Computer, Electrical & Communication Engineering (ICCECE).
- [18] W. Liu, G. Zhuang, X. Liu, S. Hu, R. He and Y. Wang, "How do we move towards true artificial intelligence," 2021 IEEE 23rd IntConf on High Performance Computing & Communications; 7th IntConf on Data Science & Systems; 19th IntConf on Smart City; 7th IntConf on Dependability in Sensor, Cloud & Big Data Systems & Application (HPCC/DSS/SmartCity/DependSys), Haikou, Hainan, China, 2021, pp 2156-2158, doi: 10.1109/HPCC-DSS-SmartCity- ependSys53884.2021.00321.
- [19] M. Hou and X. Han, "Constructive Approximation to Multivariate Function by Decay RBF Neural Network," in IEEE Transactions on Neural Networks, vol. 21, no. 9, pp. 1517-1523, Sept. 2010, doi: 10.1109/TNN.2010.2055888.
- [20] Y. -F. Li, L. -Z. Guo and Z. -H. Zhou, "Towards Safe Weakly Supervised Learning," in IEEE Transactions on Pattern Analysis and Machine Intelligence, vol. 43, no. 1, pp. 334-346, 1 Jan. 2021, doi: 10.1109/TPAMI.2019.2922396.
- [21] Ł. Kułacz and A. Kliks, "Reliability of Bio-Inspired Ultra-Dense Networks," 2020 Baltic URSI Symposium (URSI), Warsaw, Poland, 2020, pp. 15- 18, doi: 10.23919/URSI48707.2020.9254015.
- [22] R. Liu, Q. Miao, Y. Zhang, M. Gong and P. Xu, "A Semi-Supervised High-Level Feature Selection Framework for Road Centerline Extraction," in IEEE Geoscience and Remote Sensing Letters, vol. 17, no. 5, pp. 894-898, May 2020, doi: 10.1109/LGRS.2019.2931928.
- [23] M. Monemian and H. Rabbani, "A New Texture- Based Segmentation Method for Optical Coherence Tomography Images," 2019 41st Annual International Conference of the IEEE Engineering in Medicine and Biology Society (EMBC), Berlin, Germany, 2019, pp. 4750-4753, doi: 10.1109/EMBC.2019.8856610.
- [24] Ali Raza, Misha Urooj Khan, Zubair Saeed, Sana Samer, Areeba Mobeen and Aqsa Samer, "Classification of Eye Diseases and Detection of Cataract using Digital Fundus Imaging (DFI) and Inception-V4 Deep Learning Model", 2021 International Conference on Frontiers of Information Technology (FIT).
- [25] Akihiro Kuwahara, Rin Hirakawa, Hideki Kawano, Kenichi Nakashi and Yoshihisa Nakatoh "Eye Fatigue Prediction System Using Blink Detection Based on Eye Image", 2021 IEEE International Conference on Consumer Electronics (ICCE).
- [26] Xue Xia, Kun Zhan, Ying Li, Guobei Xiao, Jinhua Yan, Zuxiang Huang, Guofu Huang and Yuming Fang, "Eye Disease Diagnosis and Fundus Synthesis: A Large-Scale Dataset and Benchmark", 2022 IEEE 24th International Workshop on Multimedia Signal Processing (MMSP).
- [27] Alaa Daher and Zenah Rammal, "Development of a System for Detection, Diagnosis, and Treatment for Eye Strabismus Disease", 2021 Sixth International Conference on Advances in Biomedical Engineering (ICABME).
- [28] Pawandeep Sharma and Anand Kumar Shukla, "Analysis of Various Techniques and Methods for the Prediction of Diabetic Eye Disease in Type 2 Diabetes", 2021 Third International Conference on Inventive Research in Computing Applications (ICIRCA).

# Face Recognition based smart attendance system

Revati Pisal

Department of Electronics and  
Telecommunication  
MKSSS Cummins College of  
Engineering for Women, Pune

Shravari Padole

Department of Electronics and  
Telecommunication  
MKSSS Cummins College of  
Engineering for Women, Pune

Tejal Nehete

Department of Electronics and  
Telecommunication  
MKSSS Cummins College of  
Engineering for Women, Pune

Pooja Khiradkar

Department of Electronics and  
Telecommunication  
MKSSS Cummins College of  
Engineering for Women, Pune

Prof. Aparna Badave Department of  
Electronics and Telecommunication  
MKSSS Cummins College of  
Engineering for Women, Pune

**Abstract**—This study focuses on a face recognition-based automatic attendance system that tracks attendance for specific persons. The proposed strategy is intended to increase the effectiveness of administrators and other parties involved in sustaining an institution's attendance. When manually documenting attendance, which is laborious, time-consuming, and expensive when it comes to resources like paper, we want to minimise rather than completely remove human interactions. Additionally, utilising modern technology to supplement, take the place of, or reinstate the conventional technique of keeping track of attendance can be seen as a step toward a more promising and well-managed future for the sector, with more productive work being done through automation. Face recognition technology has enhanced access to multimedia content. Additionally, utilising face recognition to regulate access to networks makes it practically impossible for hackers to figure out a user's password while also enhancing human-computer interaction. This is one of the factors contributing to the increasing popularity of face recognition attendance systems. It is challenging to manage the presence of several pupils in a classroom under the conventional approach. Because it takes a lot of time and has a high the likelihood of mistake when entering data into the computer. A practical approach is real-time face recognition, comes with managing the majority of students' attendance on a daily basis. The practise of identifying a student's face is called face recognition. for utilising facial biometrics to take attendance. A computer system will be able to quickly locate and identify human faces in this research. Numerous algorithms and techniques have been developed to enhance face recognition performance, but our proposed system uses the LBPH (Local Binary Pattern Histogram) algorithm for face recognition by using Python programming and the OpenCV library, as well as the Haar cascade classifier to find the positive and negative of the face. The tkinter GUI interface is used in this instance for user interface purposes. They are being recorded by a security camera.

**Keywords**—*Haar cascade classifier, LBPH algorithm, Attendance system, Automated attendance, Image Processing, Face detection, Feature matching, Face recognition.*

## I. INTRODUCTION

These days, technology tries to offer fantastic knowledge-based technical advancements. One of the fascinating fields is machine learning, which enables the computer to train itself by using some datasets as input and produces the right results during testing by using various learning algorithms.

Today, attendance is seen as a key component for both students and teachers in educational institutions. With the development of machine learning technology, the system now automatically tracks the kids' attendance performance and keeps a record of the information gathered. In general, there are two distinct ways that the student's attendance system can be maintained: the Manual Attendance System (MAS) and the Automated Attendance System (AAS). In a manual student attendance management system, the instructor in charge of the relevant topic must call the students' names and manually record their attendance. Manually recording attendance may be seen of as a time-consuming operation, or occasionally a student may answer more than once regarding the absence of a buddy, or the instructor may overlook someone. Therefore, when we consider the conventional method of collecting attendance in the classroom, a difficulty occurs. We use an automatic attendance system to address all of these problems (AAS). The use of this technology has several benefits. The following are a few of them:

- Automation makes time monitoring easier and eliminates the need for staff to keep an eye on the system round-the-clock. System automation eliminates human mistake.
- Using face recognition technology, a time and attendance system may quickly and precisely identify users while properly reporting attendance, absences, and overtime.
- Without any human mistake, facial recognition software can precisely track time and attendance.
- Facial biometric time monitoring enables you to keep tabs on visitors as well as workers, allowing you to follow them about the workplace.

### A. Problem Statement

The daily evaluation of the classroom heavily weighs attendance. The instructor often checks it at the start and end of class, although it's possible that they could overlook someone or check certain students' answers more than once. Face recognition technology based on high-definition monitor video and other information technologies is used to solve the problem of identifying faces for the purpose of collecting attendance. The goal of face recognition is to enable computers to quickly and accurately locate and identify human faces in pictures and movies. The effectiveness of face recognition has been enhanced by the

development of several algorithms and methods. Deep learning has recently received a lot of attention for computer vision applications. Multiple faces may be quickly and automatically detected and recognised by the human brain. However, it is exceedingly difficult for a machine to perform all the complex tasks at a human brain level. Biometrics includes facial recognition as a key component. Basic human characteristics are compared to the data in biometrics. Face recognition is a notion that enables a computer system to quickly and accurately locate and identify human faces in pictures or movies. For enhancing the effectiveness of face recognition, several algorithms and methods have been developed. Deep learning has recently been extensively investigated for computer vision applications. The human brain is capable of instantaneously and automatically identifying several faces. On a computer, however, it is exceedingly difficult to complete all the tough tasks at the level of the human brain. Face recognition is a crucial component of biometrics. The fundamental characteristics of a human are compared to the data in biometrics.

### B. Motivation

The accuracy of the data obtained is the largest problem, according to the prior attendance management system. This is due to the possibility that the original individual recording the attendance may not really do so; in other words, a third party may record a specific person's attendance without the institution's knowledge, which disregards the data's accuracy. For instance, if student A was too sluggish to show up to a certain class, student B assisted him/her in signing for attendance, even though student A hadn't actually been there. However, the system ignored this error because there was no enforcement being used. If the institution decides to implement enforcement, it may need to squander a lot of time and resources, which is not at all realistic. As a result, no recorded attendance in the old system may be used for analysis. The second issue with the prior technique is that it takes too much time. Assuming a student takes around a minute to write his or her name on a 3–4 page name list to indicate attendance. Only about 60 pupils can sign their attendance in one hour, which is obviously time-consuming and wasteful. The third problem is with the genuine interested party's ability to obtain such data. For instance, the majority of parents are quite concerned about tracking their child's locations to make sure their child is actually attending the classes at school or in college. The parents cannot obtain this information under the prior system, though. To increase efficiency, data correctness, and information accessibility for those who are entitled to it, the prior system has to be evolved.

### C. Objectives of Project

- To create a convenient, self-powered portable Smart Attendance System.
- To make sure that the procedure for recording attendance is quicker than the old one, which could record each student's attendance in as little as three seconds.
- Provide adequate RAM for the database to be stored.
- Accurately able to identify a person's face using the face database.

- Make attendance tracking available to parents.
- Create a database for the system that tracks attendance.
- Offer a user-friendly interface for non-admins (parents) to verify their child's attendance by sending the attendance as well as allowing administrators to view the attendance database.
- Enable new employees or students to use a GUI to store their faces in the database.
- Able to inform the user whether or not the face-recognition procedure was successful.

## II. RELATED WORK

A Arjun Raj; Mahammed Shoheb; K Arvind; K S Chethan et.al. In this project, we employed an intelligent attendance system based on facial recognition. We have suggested putting in place a "Smart Attendance System for Face Recognition" that has several uses. Due to face authorisation, the current implementation incorporates facial identification, which saves time and eliminates the possibility of proxy attendance. Now, this approach may be used to a situation where involvement is crucial. The prerequisites for this system are a Raspberry Pi, Open CV, and Dlib written in Python. To identify a person's face in real time, the system in use employs the LBPH face recognizer. Light has an impact on both Eigen faces and Fisher faces, hence it is impossible to guarantee ideal lighting in real life. To solve this issue, the LBPH faces need to be improved. This method decides who is present and who is not by comparing the test image to the training image. The technology automatically updates an excel sheet that contains the attendance data.

Shubhobrata Bhattacharya, Gowtham Sandeep Nainala, Prosenjit Das and Aurobinda Routray et.al. Students' frequent attendance in class is crucial for performance evaluation and quality control in the current educational system. Calling names or signing documents are the traditional procedures used in the majority of institutions, both of which are time-consuming and unsafe. The automated attendance management system is discussed in this article for convenience or data accuracy.

Teddy Mantoro, Media A. Ayu Faculty of Engineering and Technology Sampoerna University, Jakarta, Indonesia et.al. This essay makes suggestions for how to speed up facial recognition while maintaining accuracy. A hybrid technique combining Haar Cascades and Eigen face approaches, which can identify numerous faces (55 faces) in a single detection phase, was used to complete the suggested face recognition procedure. With an accuracy level of 91.67%, our enhanced face recognition technique was able to identify several faces.

Syam Kakarla , Priyaranjan Gangula , M.Sai Rahul , C. Sai Charan Singh and T. Hitendra Sarma et.al. The procedure of gathering student face data is included in the unique CNN architecture for face recognition system that is suggested in this study. It has been demonstrated experimentally that the suggested CNN design offers 99% accuracy. The "Smart Attendance Management System (SAMS)," a web-based programme that uses facial recognition to give attendance of students in real time, is also developed utilising the

suggested CNN architecture. The suggested application is simple to instal and keep up with.

Jaehoon (Paul) Jeong, Minh Kim, Yeonghyeon Lee, and Patrick Lingg et.al. Students' student identification (ID) cards or mobile applications are used in the current attendance verification method. The procedure of verifying attendance may be more easy for both students and instructors if it is handled automatically by an attendance checking system. This study suggests an IoT-based Automatic Attendance System for obtaining these benefits (IAAS). IAAS is a facial recognition-based attendance monitoring system.

### III. SYSTEM ARCHITECTURE

We employed the LBPH face recognition algorithm along with the Haar Cascade face detection technique in this suggested automatic attendance management application. The Python module Tkinter package, which is a quick and simple approach to develop a GUI system, was used to create the Graphical User Interface (GUI) screen for this software, which is displayed in Fig. 1.

The application will include features like photographing pupils, recording their student ID, name, and phone number in the database, training the photographs recorded there, and starting to recognise students who are in the classroom. The application will analyse the faces of the pupils in the classroom from the webcam when the instructor needs to record their presence before further identification. Figure 1 depicts the planned plan's portions. The next part goes into great depth on how each step is put into practise.

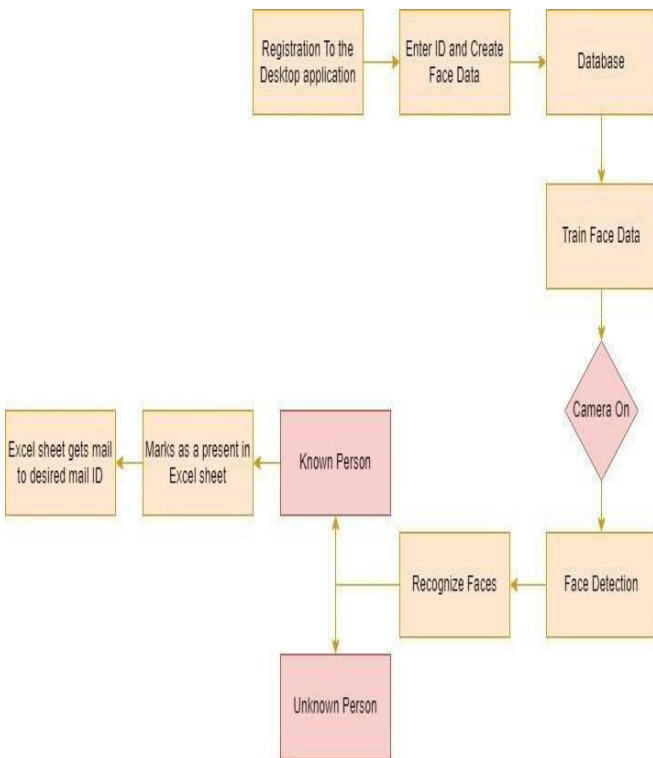

Fig .System Architecture

### IV. METHODOLOGY AND ALGORITHM

The application will analyse the faces of the pupils in the classroom from the webcam when the instructor needs to record their presence before further identification. Figure 1 depicts the planned plan's portions. The next part goes into great depth on how each step is put into practise.

Input: live video stream with student face visible Output: Attendance excel sheet.

1. Convert each image frame from RGB (Red, Green, Blue) to gray scale(B/W).
2. Implement the Haar algorithm classifier for facial detection and identify the Region of Interest(ROI).
3. Then apply the LBPH algorithm on the ROI to extract the image features.
4. if for enrollment then features and details are stored in the database else if for verification then do Post-processing

#### A. Face detection and preprocessing

The picture frame must first be converted from RGB colour to grayscale. We employed the suggested haar cascade classifier [8] for face identification, where the cascade function is trained to recognise and extract features from pictures. We employ haar characteristics like edge, line, and four-rectangle for this aim.

Numerous computations and attributes are needed for a huge image or a dynamic image size, and the majority of them will change.

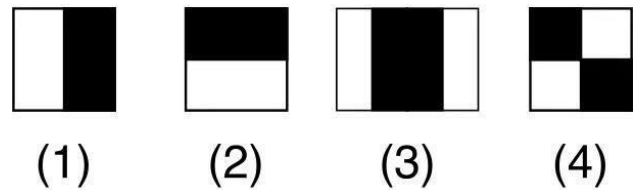

Fig.2 Harr Features

#### B. Face Identification

We utilised the LBPH algorithm for facial recognition because of its reliability and capacity to distinguish between the front and side faces. Additionally, the LBPH algorithm performs better than Fisherfaces and Eigenfaces [6]. They search for characteristics that more accurately represent the face in the picture using the LBPH algorithm [5]. This approach is straightforward since it takes characteristics from photos and inserts them into your local dataset in the event that an anonymous image develops a comparable algorithm and compares the outcome with each image in the dataset. Compared to other algorithms, this method performs effectively in a range of settings and lighting conditions. The Local Binary Pattern (LBP) function produces a picture that extracts the features and traits of the image more effectively. It makes use of the scale factor notion, radius, and neighbours. [7] The visual frame is first transformed into a 3X3 pixel matrix. The value will be provided as 1 and 0 in the appropriate pixel region if the nearby pixel in the matrix is greater than the centre pixel of that matrix. The queue's pixel values will now be transformed into binary numbers. The binary number should be converted to a decimal number, and then to the matrix's average pixel value. In order to produce a new, bigger histogram when the picture is transformed into an LBP form,

histograms are extracted from each image grid and synced. The characteristics of the original image are displayed in the accompanying histogram. Each histogram corresponds to a database-stored facial picture. We will repeat the previous procedures with the new picture to create a new image histogram.

0	0	1	1
0	0	1	1
0	0	1	1
0	0	1	1

0.1	0.2	0.6	0.8
0.3	0.2	0.6	0.8
0.2	0.1	0.8	0.6
0.2	0.1	0.8	0.9

Fig. 3 Pixel Values: 0 and 1 for ideal case (Top box), Normalised greyscale values for real cases (Bottom box)

C. Post-Processing

Now that the student's picture has been recognised, the training dataset's histograms are compared with the new histogram using Euclidean distance, and the optimal histogram is the one with the lowest distance and lowest confidence. It also extracts the ID for that histogram. The extracted ID's information are displayed on the frame if confidence is lower than 50, and the names are updated in the attendance excel sheet only if the student's face can be identified. If not, the phrase "Unknown" will appear on the frame and that specific student's photograph will be saved in a different folder. This makes it easier to identify any additional pupils in the classroom and helps to prevent students from being incorrectly labelled as "unknown."

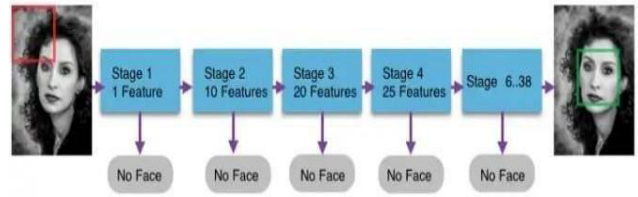

Fig 4. Harr Cascade Classifier Method

V. CONCLUSION

One of the most popular and successful methods for face recognition is LBPH. Even students with spectacles or beards may be correctly identified by our technology, which also notifies parents via SMS when a kid is absent from class. The dataset in this case has a little difficulty. A better dataset might be created using this technique in the future, potentially producing results that are more accurate. By creating fresh training examples, we may enhance the haar cascade classifiers' ability to identify unfamiliar people. If an intruder is discovered in the class, a system alarm (voice and visual) may be incorporated.

REFERENCES

[1] Li Cuimei, Qi Zhiliang, Jia Nan, Wu Jianhua, "Human face detection algorithm via Haar classifier combined with three additional classifiers", 13th IEEE International Conference on Electronics Measurement Instruments (ICEMI), 2017

[2] Qingdong Liang, Wenting Fang, "College Student Attendance System based on Face Recognition", IOP Conf. Ser.: Mater. Sci Eng. 466 012107, 2018.

[3] Kritika Shrivastava, Shweta Manda, Prof. P.S. Chavan, Prof. T.B. Patil, "Conceptual model for proficient automated Attendance System based on Face Recognition and Gender classification using Haar Cascade, LBPH algorithm along with LDA model", International Journal of Applied Engineering Research ISSN 09734562 , Volume 13, Number 10 pp.8075-8080 © Research India Publications, 2018.

[4] Deepan.P1, Raja Vignesh.R2, Venkateswaran.S3, "Face Recognition based Automated Attendance Management System using Hybrid Classifier", International Research Journal of Engineering and Technology(IRJET) e-ISSN: 2395-0056, vol.4 Issue:

[5] p-ISSN: 2395-0072, May 2017.5 Subarna, B. Viswanathan, "Real time Facial expression recognition based on deep convolutional spatial neural networks", D.M. International Conference on Emerging Trends and Innovations in Engineering and Technological Research, ICETIETR 8529105, 2018.

[6] P.K. Pani and P. Kishore, "Absenteeism and performance in a quantitative module A quantile regression analysis," Journal of Applied Research in Higher Education, vol. 8 no. 3, pp. 376-389, 2016. U. Thakar, A. Tiwari, and S. Varma, "On Composition of SOAP Based and RESTful Services," IEEE 6th Int. Conference on Advanced Computing (IACC), 2016.

- [7] R. Samet, G. S. Shokouh, J. Li, "A Novel Pose Tolerant Face Recognition Approach", 2014 International Conference on Cyberworlds, pp. 308-312, 2014.
- [8] R. Samet, S. Sakhi, and K. B. Baskurt, "An Efficient Pose Tolerant Face Recognition Approach", Transactions on Comput. Science XXVI, LNCS 9550, pp. 161-172, 2016.
- [9] L. Masupha, T. Zuva, S. Ngwira, and O. Esan, "Face recognition techniques, their advantages, disadvantages and performance evaluation," Int. Conference on Computing, Communication and Security (ICCCS), 2015.
- [10] S. Noguchi, M. Niibori, E. Zhou, and M. Kamada, "Student Attendance Management System with Bluetooth Low Energy Beacon and Android Devices," 18th International Conference on NetworkBased Information Systems, pp. 710-713, 2015.
- [11]. S. Konatham, B.S. Chalasani, N. Kulkarni, and T.E. Taeib, "Attendance generating system using RFID and GSM," IEEE Long Island Systems, Applications and Technology Conference (LISAT), 201611 X. Zhu, Z. Lei, X. Liu, H. Shi, and S. Z. Li, "Face alignment across large.

# Live Inventory Monitoring for Contactless Smart Vending Machine

Muskan Singh  
Department of Electronics &  
Telecommunication  
Sandip Institute of Technology &  
Research Center  
Nashik, India  
singhmuskan453@gmail.com

Rutuja Mane  
Department of Electronics &  
Telecommunication  
Sandip Institute of Technology &  
Research Center  
Nashik, India  
rutujamane226@gmail.com

Saurabh Chaudhari  
Department of Electronics &  
Telecommunication  
Sandip Institute of Technology &  
Research Center  
Nashik, India  
saurabhchaudhari3c@gmail.com

Sharwari Dhakne  
Department of Electronics &  
Telecommunication  
Sandip Institute of Technology &  
Research Center  
Nashik, India  
sharwaridhakne@gmail.com

**Abstract**—This paper aims to transform conventional vending machines by retrofitting new components to enhance their functionality and effectiveness. The primary objective is to introduce live inventory monitoring for contactless smart vending machines. This will allow real-time monitoring of the sales and stock of napkins remotely. The paper will also incorporate features such as mobile operation, dual payment options (cash and cashless), and cost-effectiveness. The owner can live monitor the system using the app and will be notified when stock availability is less than five. So owners don't need to visit the machine site every time to see availability/unavailability of napkins in the vending machine. The customers can see the location of the machine and product quantity available in the machine using the website remotely. The paper will contribute to the advancements in smart vending technology, providing a solution to the limitations and drawbacks of conventional vending machines. The aim of the paper is to provide a reliable and accessible source of sanitary napkins for girls during emergency needs.

**Keywords**—sanitary napkins, vending machine, contactless.

## I. INTRODUCTION

To install the vending machine that can provide sanitary napkins in an emergency, the Government of India issued the GR (Govt. Circular No. D. O. No.4-160(10)/2013-NCW Dt 03/09/2014). By ensuring sanitary napkins are readily available through sanitary napkin vending machines, we are supporting the menstrual health of women and adolescent girls. The government issued GR (Asmita 2018/ Parka. 33/ Yojana-3) on March 1, 2018, stating that girls in schools between the ages of 11 to 19 should be given sanitary napkins [1]. Though it is already installed, it is not utilized or is underutilized. The current vending machines are mostly coin operated. Though there already exist some cashless vending machines conceptually but they are yet not in use. There is no mechanism for a person refilling the stocks to know about the status of stocks available/unavailability in the system. Because of that most of the time there is a shortage of napkins in the machine. And also there is no mechanism for customers to know the product quantity available in the system. So we want to retrofit an inventory monitoring system to existing vending machines where owner can live monitor the vending

machine 24\*7 and customers can view the product quantity available in the vending machine on the go and even view the location where the system is installed.

Traditional inventory monitoring methods in vending machines include manual counting and physical inspections, which are time-consuming and often lead to inaccuracies in inventory tracking. One common method is to manually keep a log of items sold and their quantities. This method requires manual tracking by an operator, and there is a risk of errors and inaccuracies in the data. Another method is to physically inspect the machine on a regular basis to determine the current inventory levels. This method is also time-consuming and labor-intensive, as the operator must manually inspect each item in the machine and manually record the inventory levels.

Drawbacks and limitations of these methods include the risk of errors and inaccuracies in the data, as well as the time and labor required to manually track inventory levels. Additionally, manual methods are susceptible to human error, such as forgetting to record a transaction or miscalculating the inventory levels. With the advent of smart vending machines, inventory monitoring has become more efficient and accurate. Smart vending machines are equipped with sensors and technology that automate the process of tracking inventory levels. Remote management capabilities allow operators to monitor and manage multiple vending machines from a single location, saving time and reducing the need for on-site visits. With real-time monitoring and remote management capabilities. Vending machines can provide a more efficient, accurate, and cost-effective solution for inventory monitoring in vending machines.

## II. PROBLEM STATEMENT

The problem with the traditional vending machine system for dispensing sanitary napkins is that there is no mechanism available for monitoring the inventory. As a result, there is often a shortage of napkins in the machines, causing inconvenience for the users. Additionally, the current vending machines are mostly coin operated, limiting

the accessibility and convenience for users. The owner has to visit the machine site every time to check availability/unavailability of stocks in the vending machine which is time consuming. And in most of the cases the owner or person assigned to refill the stock in the vending machine forget to refill the stocks on time which results in stock unavailability in the vending machines. This can be especially challenging for girls and women who need access to napkins during emergencies. The lack of a real-time monitoring system also makes it difficult for the person responsible for refilling the napkins to keep track of the stock which results in stock out in the vending machine.

In light of these challenges, there is a need to upgrade the traditional vending machine by retrofitting to introduce remote live inventory monitoring. The objective of this paper is to design and implement a contactless smart vending machine system that can provide remote inventory monitoring for owners to keep track of the stock. So, that the system is never out of stock. To provide dual payment options for customers and customers can view location and quantity of products in the vending machine remotely.

### III. LITERATURE SURVEY

We also examined the overall structure and mechanics of existing vending machines in college and found several drawbacks that could be addressed to make them more efficient and easier to use. The literature review indicates that there are several common problems associated with existing vending machines in schools and universities. One of the biggest drawbacks is that most vending machines are coin operated. This is inconvenient for students who do not have coins or loose change. Another issue is that students have to physically go to the vending machine to see if the product is available. This can be time consuming and tedious. Additionally, it can be troublesome for owners or persons refilling to visit the vending machine site again and again to check availability/unavailability of stocks in the system. In some cases the person assigned to refill stock forgets to refill which results in stock out. Additionally, due to the COVID-19 pandemic, there has been an increase in the use of contactless payment options as a means of reducing the risk of transmission through physical contact with surfaces. The lack of cashless payment options can be a significant disadvantage, especially in today's digital age. This can be a major barrier for students who prefer cashless payment methods. To solve these problems, we would like to develop an efficient and easy-to-use vending machine.

[2] presents the design of a system that uses a unique identification code that is updated in the database when a user purchases a product. The user enters this code into a vending machine. Several cashless payment options are available and machines can be remotely monitored. [3] presents an automatic chocolate vending machine that works with Arduino to enable cashless payments using radio frequency identification (RFID) technology, overcoming the limitations of coin-based vending machines that do not return credit. [4] presents a system that uses QR code scanning for payment and product selection. [6] presents a system that after scanning the QR code, the napkins will be

distributed and the owner will receive an SMS on their registered mobile number to count the number of napkins left in the machine. Also, the owner gets an alert when the number of napkins are less. [7] presents a machine that is controlled by a Raspberry Pi programmed to connect to a RazorPay server for online payments and a MongoDB server for inventory management.

Though there are some IoT based smart vending machines with cashless payment options and live monitoring theoretically, they are not available physically in the market. Most of them are costly. And there is no App/website for customers to check the availability of stocks. So, we aim to retrofit existing vending machines and make them smart. So that vendor as well as customers can see the availability of stocks. By retrofitting traditional vending machines with these new components, we aim to promote menstrual hygiene and make sanitary napkins easily accessible for girls and women during emergency needs.

### IV. PROPOSED SYSTEM

The proposed system for this paper is a smart, contactless vending machine that incorporates live inventory monitoring. The system will be designed to retrofit traditional vending machines to make them more efficient, cost-effective, and user-friendly.

The Fig.1 shows the Flow chart of the proposed system for Users. The user has to open the website and login. After that the user will be able to see the location of the system and product quantity available in the system. If a user wants to buy the product then they can visit the site and place an order from the website. After successful payment the product will be dispatched and the user can collect the product from the vending machine.

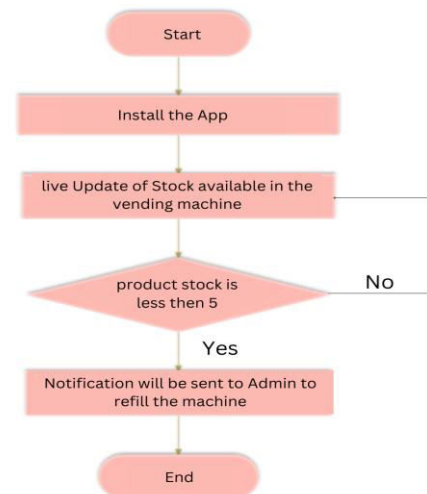

Fig. 1. Flow chart of the proposed system for Owners

The Fig.2 shows the flow chart of the system for Owners. For owners they can live monitor the vending machine from anywhere and anytime using mobile applications. And when the stock is less than 5 they will be notified by push notification from the application.

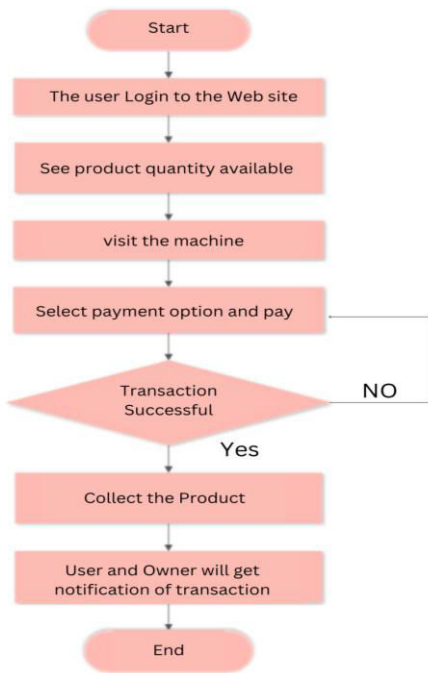

Fig. 2. Flow chart of the proposed system for Users

V. METHODOLOGY

The vending machine consists of hardware and software connected through Firebase. Fig. 3 shows the circuit diagram of the vending machine hardware prototype.

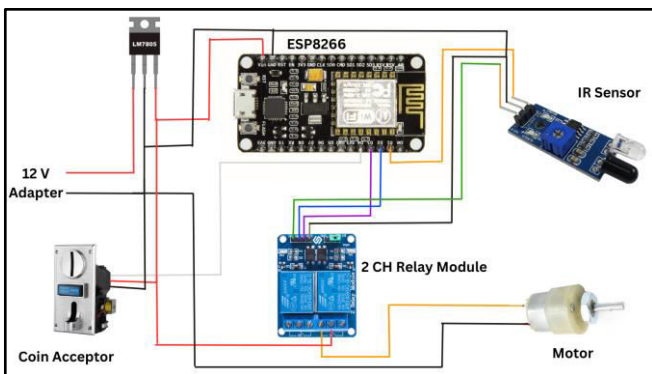

Fig. 3. Circuit Diagram

We have chosen NodeMCU ESP8266 as it can be programmed just like other microcontrollers and its advantage is that it can readily connect to the internet by WiFi. The NodeMCU ESP8266 can send data to a remote server or cloud platform, allowing for real-time monitoring and analysis of vending machine usage and performance. An IR (infrared) sensor can be used in a vending machine to detect product dispatch. The sensor detects any interruption in the light caused by the product moving from its storage location to the dispensing area by emitting an infrared beam. When a customer selects a product, the control system of the vending machine activates the mechanism responsible for dispensing the product. The IR sensor is placed in such a way that it detects any movement of the product as it is dispensed. If the sensor detects a shift in the infrared light, it sends a signal to the control system indicating that the

product has been delivered. This data is then used to update vending machine inventory levels, ensuring accurate data is maintained. When the order is placed the motor starts to rotate to push the products through a spiral coil. The IR sensor is placed in such a way that it detects any movement of product as it is dispensed. When the product falls it comes in contact with the IR sensor and the motor rotation stops. The sensor then sends the signal that product quantity is  $x-1$  now.

VI. RESULT

A mobile application is designed for owners. Fig. 4 shows the UI of a mobile application. The owners can login to their account and update machine information. While refilling the machine the owner adds the total quantity of products in the system. the owner can monitor the machine remotely. When the quantity of product is less than 5 the mobile app sends notification to owners to refill the stock. Fig. 5 shows the push notification for less stock.

A website is designed for customers to remotely view the location and product quantity in the machine. Fig. 6 shows the customer website. The customers can select their preferred payment option (coin or contactless). When payment is complete, the firmware on NodeMCU ESP8266 sends a signal to Motor and rotates the spiral coil to make the product fall. When the product falls it comes in contact with the IR sensor and motor rotation stops. And a signal is sent to the microcontroller to update product quantity  $x-1$  (i.e., quantity present in system  $-1$ ) in a real-time database.

A. Software prototype

1) Owner Application

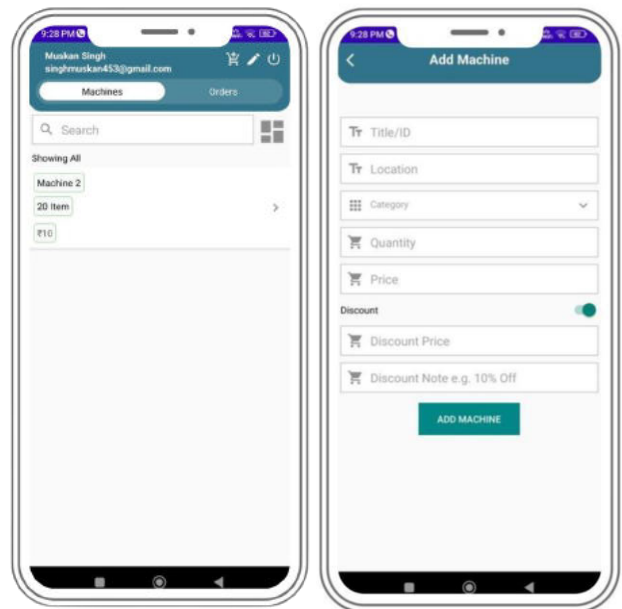

Fig. 4. Owner Application UI

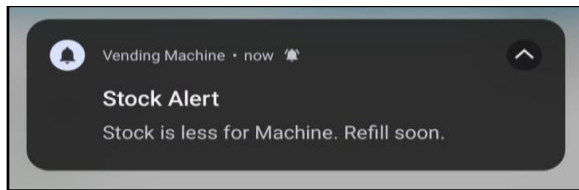

Fig. 5. Notification for less stock

## 2) Customer Application

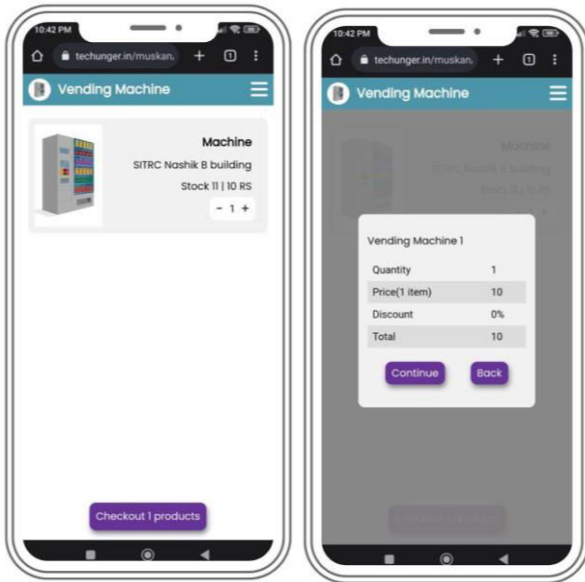

Fig. 6. Customer website pages

## B. Hardware prototype

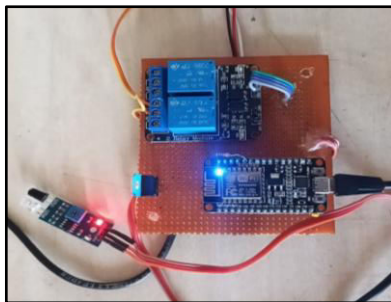

Fig. 7. Hardware prototype

## VII. CONCLUSION & FUTURE SCOPE

The proposed vending machine system for dispensing sanitary napkins will offer numerous benefits to both the owner and users. By installing these machines in various locations such as public restrooms, schools, offices and rural areas, users can access sanitary napkins in a convenient and discreet manner. The mobile Application allows real-time monitoring of vending machines for owners. Additionally, the owner will receive notifications when napkin levels run low, ensuring that the vending machine is always well-stocked. The customers can view the quantity of products

available in the vending machine without visiting the machine and also view the location of the machine and visit the machine if stock is available. Dual payment options (coin, Cashless) are available for added flexibility for customers. The proposed system is an innovative solution that can help address menstrual health needs while providing an improved user experience.

In the future we can integrate the geolocation of vending machines in the app so users can find the exact location of vending machines. These vending machines can be used for other products also. Smart vending machines can be integrated with loyalty programs, allowing customers to earn rewards for purchases and encouraging repeat business. Smart vending machines can be used to offer a wider range of products, including fresh and perishable goods, by incorporating refrigeration and other temperature-controlled technologies. The system can be expanded to include other hygiene products such as sanitizers, and wet wipes.

## VIII. ACKNOWLEDGEMENT

We would like to express our heartfelt gratitude to Prof. Dr. G.M. Phade, our project guide, for her keen interest and encouragement in our project. Finally, we would like to thank our family and friends who have always been by our side.

## REFERENCES

- [1] Prof. Sandip R. Aher, Nayan S. Ghorpade, Anuradha K.Bhuse and Shruti V.Aher, "IoT Based Smart Cashless Vending Machine for Sanitary Napkin Dispenser," International Journal of Scientific Research in Engineering and Management (IJSREM), vol. 06, pp. 1-5, May 2022.
- [2] Sooraj P, Bony Mons and Dr. Jinsa Kuruvilla, "IoT Based Vending Machine with Cashless Payment," International Research Journal of Engineering and Technology (IRJET), vol. 06, pp. 247-261, June 2019.
- [3] Kanagasabapathi V, Naveenraj K, Neelavarnan V and Naveen raj S, "Automatic chocolate vending machine", 5th International Conference on Advanced Computing & Communication Systems (ICACCS), IEEE, pp 584-587, 2019.
- [4] Wahidul Alam, Fahima Sultana, Jubaida Saba and Ayikutu Courage Kofi, "IoT Based Smart Vending Machine for Bangladesh", IEEE International Conference on Robotics, Automation, Artificial-intelligence and Internet-of-Things(RAICON), pp 73-76, 2019.
- [5] Arcot Aashish Arun Kumar and Ramarangula Saideepak, "Sanitary Vending Machine (Stree - Swachhata)," International Research Journal of Engineering and Technology (IRJET), vol. 07, pp 268-272, June 2020.
- [6] Chandrakant Bhang, Tanvi Patil, Shubham Dhakne and Parmeshwar Chavhan, "Sanitary Napkin Vending Machine Using QR Code," International Journal of Advance Scientific Research and Engineering Trends, vol. 6, pp 33-35, July 2021.
- [7] Vivek Manda, Surender B, D.Mahesh, B.Sanjeevlu, H.Roopak, V.Ravi Kumar, B.Sidharth Sarat, "IoT Based Sanitary Pad Vending Machine," International Journal for Modern Trends in Science and Technology, pp. 48-54, 2021,
- [8] Shreeshayana R, Simrah Fathima "Sanitary Napkin Vending Machine with Incinerator for Menstrual Hygiene," International Research Journal of Engineering and Technology (IRJET), vol 08, pp. 57 -67, Oct 2021.
- [9] Dr. Gayatri Makarand Phade, Er. Prashant Gorakhanath Salunke, Er. Ganesh Liladhar Attarde, Er. Vaibhav Vijay Joshi "DUAL PAY MODE SANITARY NAPKIN SELF-DISPENSING MACHINE", Application No.201821004599 A, 03/01/2020.

# IoT based Smart Wireless Noticeboard

Miss. Mugdha A. Tamhan

Student of Department of Electronics and Communication Engineering  
Shri Sant Gajanan Maharaj College of Engineering

Shegaon, Maharashtra, India  
mtamhan@gmail.com

**Abstract**—Internet of things allows all the devices to connect to the internet. These devices and sensors use internet connectivity to collect and share data from their environment with other devices over a network without human interference. The power of IoT can also be realized through innovative use of raspberry pi. IoT with the help of raspberry pi, makes things smart. The desire to make things smart, brought several revolutions in existing technology. Noticeboard is the thing which is becoming smart here, as it is the key element in any organization, railway station, educational institutions etc. Conventional Analog type notice board will be replaced by digital notice board to make information dissemination easier in a paperless community.

This research focusses on the basic concept of IoT based wireless noticeboard using Raspberry pi. The main objective of this project is to design simple, highly secured, easy to install, user-friendly system which display notices in user required format with achievement of fast transmission of data from admin to reader. In this proposed system a php based portal is designed for the admin panel. Raspberry-pi is used for accessing wireless notice board which displays the notice in the form of text, image pdf according to user choice. Wi-Fi connected Raspberry pi fetches recently uploaded information and displays it on the digital notice board.

**Keywords**—Wireless Noticeboard, IoT, internet, Wi-Fi, Raspberry pi

## I. INTRODUCTION

A noticeboard is something that needs to be “noticed”. To effectively implement this, noticeboard must be attractive, appealing, interesting, eye-catching which gravitate people towards it. Noticeboard’s primary goal is public awareness. It displays key information about upcoming events, including news, messages, advertisements and vital facts. Noticeboards are used almost everywhere in crowded public areas like bus stops, railway stations, hospitals, restaurants, colleges, offices and many others to inform concern public regarding relevant schedules and events. However, daily notice pasting is a challenging task, as a different individual is essential to update traditional noticeboard. The entire process from making a decision to printing of notices consumes time and circulating these notices among people consumes extra time. The traditional noticeboard is a solid flat surface that is positioned in key areas as a place where notices and articles are posted in printed form.

In educational institution, noticeboards are used to update students regarding different schedules, reminders, warnings, results and appointments. As these notices are placed on the same noticeboards, some of the older notices are not removed, as a result in a short period of time the noticeboard is filled with number of notices, making it

difficult to see any important notices or may happen any important message remained unnoticed.

Advancement of technology leads to digital revolution. Digitization in the field of communication leads to quick wireless data transfer. Digital noticeboards are those which displays notices in digital format. Digital noticeboard allows secured authenticate display of notices with user required format like word, pdf, and images. These noticeboards instantly change upon updating the information. Also, multiple notices can be shown by using scrolling feature. Digital noticeboard not only allows faster, secure, authenticate, attractive, digitized information dissemination but also provides record tracking, scrolling and information storing feature.

## II. LITERATURE REVIEW

Teckchandani Y. in his paper, “large screen wireless notice display system (2015)” proposes a method to overcome the drawback of small sized 16\*2 LCD display with comparatively bigger display like LED screens, computer screens, TV screen etc which can be further used for information dissemination. HTML is used to display the outcomes, as it offers variety of customization options like font size, background color and display of multiple notices at a time. A web browser operating on the Raspberry Pi can display this HTML output. The notice should be sent in the form of SMS to GSM modem. This makes reception of messages wireless. Raspberry Pi checks the GSM modem for new messages periodically [1].

In paper, “Smart Notice Board” Shruthi K. develops a GSM based smart noticeboard which basically consists of two units, an end user’s mobile unit and a control unit. The setup of LCD display, the Arduino UNO board (having ATmega328 microcontroller) and the GSM (ITEAD SIM 900 GPRS) module together create control unit. The information to be displayed must be sent in the form of SMS to the control unit. GSM module will receive the message, Arduino will transfer it from GSM module to LCD display. LCD display unit will display the message [2].

In paper “The Development of Simple and Low-Cost Android Based Wireless Noticeboard” Neeraj Khera presents, a system comprised of wireless serial data communication based on Bluetooth or Wi-Fi. User specific Android application programs are designed for Bluetooth and Wi-Fi communication between android based handheld PC and remote wireless display unit. The Android PDA and the connected Bluetooth devices communicate with each other through Bluetooth application program to send (or receive) the messages in hexadecimal (hex) as well as string format. Receiver side consists of, the microcontroller along with HC-

05 module, used to store the received message and the display the same on the LCD screen. Android based PDAs communicate with Wi-Fi device through Wi-Fi keyboard application program. The Wi-Fi transceiver module (ESP 8266) and Wi-Fi keyboard application program installed on Android PDA communicates with each other via Wi-Fi network, comprises of receiver section of the system. Microcontroller is interfaced with ESP 8266 module which is programmed to save the received message and display the same on the LCD screen.

For communication in a Bluetooth mode, a personal Area Network is created in the 10-15 meters range specified with frequency band of 2.45 GHz for connection. With AT commands preprogrammed to receive user messages, an Android PDA equipped with an ESP 8266 module is connected to a microcontroller having range of 200-250 meters, for Wi-Fi communication mode. Wi-Fi communication technique improves the range of receiving messages on wireless notice board but it is not affordable as it is costlier [3].

Traditional noticeboards make people manually gather at the noticeboard and read the notices. This is a time-consuming process. Rajesh G. P. in his paper "Near Field Application: NFC Smart Notice Board", suggests a solution of using NFC application. The concept used here is, NFC tags are used to display noticeboard. The notices to be displayed should be programmed in each NFC tag. Simply update the notice through NFC tag when there is a need to display circular. NFC enabled smartphones are used to scan the notices through NFC tags which downloads notices online to their handheld devices. Provides end user appropriate time to read notices thoroughly. NFC tags works on the principal of RFID having small range, 13.56 GHz operating frequency and maximum 10 cm communication range. Once implemented NFC enabled noticeboards are efficient in saving time and provides end user facility to read notices with their convenient time [4].

"Smart Notice Board System", written by Dhara Rangani and group proposes a noticeboard system based on Internet of Things technology. The message / notice to be displayed is sent by authenticate person using android application or web interface to the server. The server will check for authentication of message through flowchart process. If authenticity is valid, the message will be transferred to LCD display. Android based cellphone and ESP8266 will communicate with each other through MQTT broker. Authentication system is deployed on Arduino board, Arduino C is used for coding project. ESP8266 and MQTT also supports Arduino C. For android application, android studio is used [5].

Ceren Yasa in their paper, "Interactive Digital Notice Board" developed a system which makes use of Digital Signage method. Wireless access is necessary for a system based on digital signage method in order to enable remote content management. A web server is required to control this system. This newly developed system also able to classify age of the people, following to which font size should be adjusted. Deep learning - a part of machine learning is used to develop age classification application. A graphical user interface is designed using Raspberry Pi which includes time, date, weather and announcement information for announcement screens. A website is designed for secured

storing of announcement information by authorized person. Interface is made attractive by adding different notification sounds and background colors. Age detection and classification application with font size enhancement procedures with deep learning method for aged people also developed [6].

In paper "A Novel Method of IoT Based Smart Notice Board Using Raspberry Pi", Venkatesh S Kumar proposed a system comprised of two sections, transmitter section and receiver section. Notice can be sent through website, which will only be accessed by authenticate person with authenticate login credentials. Additionally, registered users receive notification regarding notice updation. Raspberry pi is linked with Wi-Fi at receiving section, which fetches the information and displays the same on noticeboard. [7]

### III. BLOCK DIAGRAM

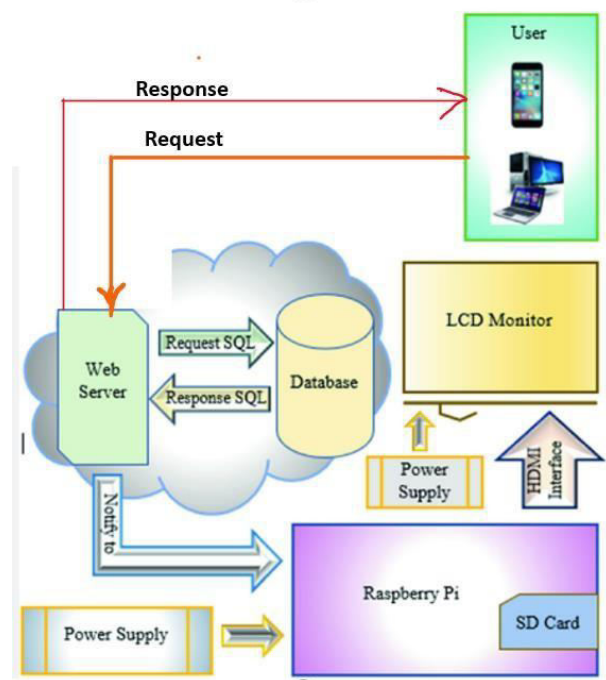

Fig 1. shows block diagram of the system

As shown in the above fig. this smart wireless noticeboard system, in transmitter section a web server is designed which upon request fetches the information and send it to display connected with raspberry pi. Raspberry pi works as the main processing unit. It is used to pull data from web server and display it on the display device It allows to display messages, images and other information wirelessly. The other system requirements are given in the next section.

### IV. SYSTEM REQUIREMENT

system requirement basically consists of hardware requirement and software requirement.

### A. Hardware Requirement:-

#### Raspberry Pi: -

It is also called as the control unit of the system. It is configured by installing necessary software. Any model of raspberry pi with built in wi-fi connectivity can be suited for system. Here we have chosen Raspberry pi Zero W.

#### SD card: -

SD card will be required to install the required operating system like Raspbian OS.

#### HDMI cable: -

This cable is required for connecting display unit with the Raspberry pi. Here as we have used Raspberry pi zero, we have used mini-HDMI to HDMI cable.

#### Display unit: -

This will display the content sent from user. This is the main important part of the system.

### B. Software Requirement:-

#### Raspbian: -

Raspbian is an operating system of Raspberry pi. It is required to be installed in SD card for proper working of Raspberry pi.

#### Web server: -

A server is a computer that runs websites. The basic objective of the web server is to store, process and deliver web pages to the users.

Raspberry pi zero w is set up by installing necessary software. Display unit is connected with wi-fi equipped raspberry pi using HDMI cable. Display setting on your raspberry pi can be configured to ensure proper working of display. To interact with the noticeboard, a web interface is created which allows adding messages and notices to the noticeboard. Next step is to host the web interface using web server. Once the web interface is properly implemented, information transmission becomes easier. To display content on the noticeboard, the raspberry pi will pull data from web server and display it on the display device.

## V. SYSTEM ARCHITECTURE

This system is basically designed by considering a department in educational institution. Every department consists of 2 levels- professors and HOD, all under the 1 highest authority- principal. This creates a hierarchical system, in which notice generated by lower level is forwarded for approval to higher level, specifically they will take the decision of displaying the notice. This system itself verifies notice authentication and document content verification by keeping track of who and when has posted.

This hierarchical system consists of 3 modules, as given below:

### A. Professor

At this authentication level, users have the authority to login the system with authenticate login credentials, generate

notices and forward the department level notices to HOD and institute level to Principal.

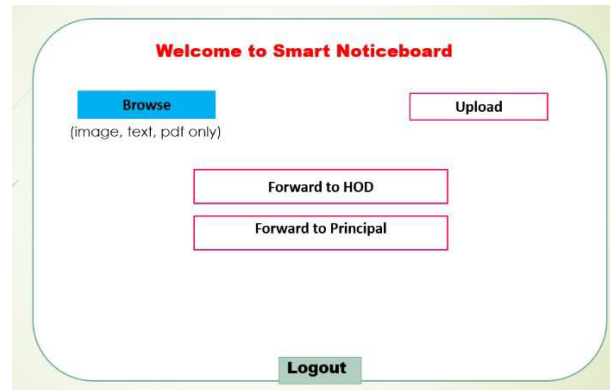

Fig. 2 Overview of Professor Module Functionalities

### B. Head of Department

At this authentication level, users have the authority to login the system with authenticate login credentials, approve notices generated by professors, disapprove notices with remark or forward the notices to Principal for approval by higher authority.

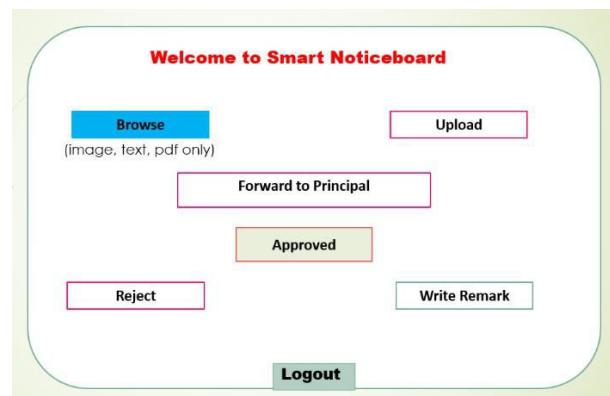

Fig. 3 Overview of HOD Module Functionalities

### C. Principal

At this authentication level, users have the authority to login the system with authenticate login credentials, generate notices and approve the notices forwarded by professor and HOD.

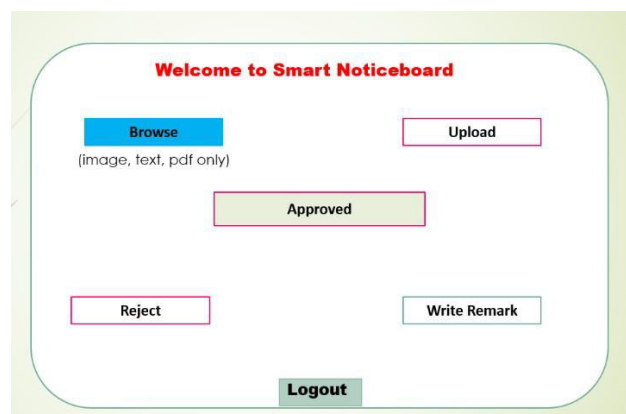
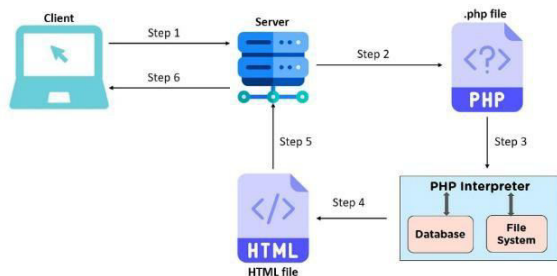

Fig. 4 Overview of Principal Module Functionalities

## VI. PROPOSED METHODOLOGY

This section gives a basic overview of the system. In this proposed system a php based portal is designed for the admin panel. Raspberry-pi is used for accessing wireless notice board which displays the notice in the form of text, image pdf according to user choice.



**Fig. 5 Information flow diagram**

Above fig. shows how php works. Firstly, client requests the web-page on the browser. The server where PHP software is already installed then checks for the .php file associated with the request. If found it sends the file to the php interpreter, which checks for requested data into the database. The interpreter then sends back the requested data output as HTML webpage. The web server receives the HTML file from the interpreter and sends to the browser.

System consists of two sections sender and receiver section. As shown in the flowchart to get access of sender section we must login to web page with login credentials. If login credentials are authenticated, user is forwarded to application landing page. If authentication fails, user remains on the login page with message “Invalid Username or Password.” After successful login, user can upload file (“text/image/pdf”) according to requirement. Now this file is stored on the cloud.

In receiver section, wi-fi connected Raspberry Pi is used for accessing internet. Raspberry Pi works on the power supply of 5V. Once Raspberry Pi is turned ON it will get connected to the internet and fetches recently uploaded information and displays it on the digital notice board.

Provision for alteration, modification, deletion of messages also provided along with the facility of changing background and font theme, size, color. Also, you can add delay or scrolling feature.

## VII. ALGORITHM

Following step by step procedure will explain the actual working of the system: -

1. Start
2. Choose your role before login.
3. Login to access notice board.
4. If the user is valid then go to step 5 otherwise contact to admin.
5. Select Information in the form of image, pdf and text files

6. For professor module uploaded file will be forwarded to principal and HOD. Decision of selection and rejection will be taken by HOD or Principal here.
7. For HOD module, he/she can upload the file also the decision of pending file from professor module will be taken here. Selected file will be uploaded to noticeboard. Also, the option of forward to principal is available here.
8. For principal module, he/ she can upload their own notice. The pending file of Staff/ professor/ HOD will be either approved or rejected with comment.
9. Store the message.
10. Set the duration of displayed messages.
11. Set maximum limit for the size of image to be displayed.
12. If the received image is less than the limit it will be directly displayed. Otherwise, image will be resized.
13. When pdf is received, it will convert to image.
14. Received image and text files
15. Display stored messages in First in first out order (FIFO)
16. Repeat above steps when power supply maintained.
17. Stop

## VIII. FLOWCHART OF ADMIN LOGIN SYSTEM

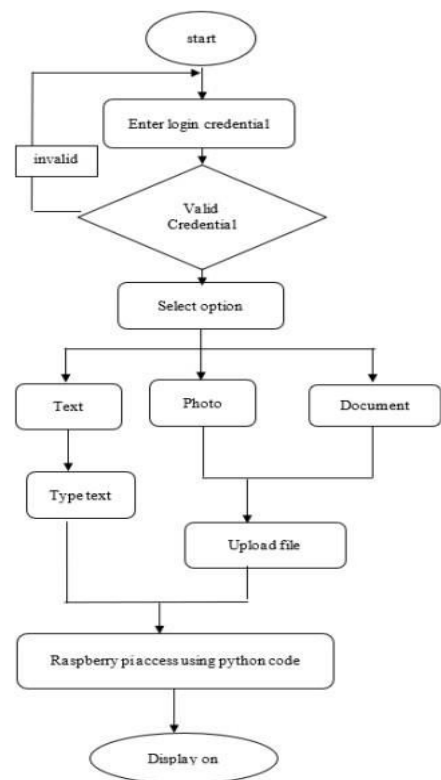

**Fig. 6 Flowchart of admin login system**

## IX. CONCLUSION

Advancement in technology and digitization in the field of wireless communication allows easier implementation of digital notice board to display notices in user required format. Various studies are overviewed to understand the technologies and features proposed to implement the system. Pros and Cons are also studied to define the objectives of the paper. We have proposed the design of a digital noticeboard system equipped with Raspberry Pi, which displays the message of the user by providing notification on the screen. Raspberry Pi is called a single board computer (SBC) which efficiently works with software in digital notice boards. Application areas for this proposed system include educational institutes, shopping malls, restaurants, hospitals etc. As this system promises to provide faster, secured, wireless, authenticate information communication, further study in this area will boom the researcher and end user.

## REFERENCES

- [1] Teckchandani, Y., Perumal, G. S., Mujumdar, R., & Lokanathan, S. (2015, December). Large screen wireless notice display system. In 2015 IEEE International Conference on Computational Intelligence and Computing Research (ICIC) (pp. 1-5). IEEE.
- [2] Shruthi, K., Chawla, H., & Bhaduri, A. (2013). Smart notice board.
- [3] Khera, N., Shukla, D., & Awasthi, S. (2016, September). Development of simple and low cost Android based wireless notice board. In 2016 5th International Conference on Reliability, Infocom Technologies and Optimization (Trends and Future Directions)(ICRITO) (pp. 630-633). IEEE.
- [4] Rajesh, G. P., Pattar, P., Divya, M. N., & Prasad, V. (2016, July). Near field application: NFC smart notice board. In 2016 Thirteenth International Conference on Wireless and Optical Communications Networks (WOCN) (pp. 1-5). IEEE.
- [5] Rangani, D. G., & Tahilramani, N. V. (2017, December). Smart notice board system. In 2017 3rd International Conference on Applied and Theoretical Computing and Communication Technology (iCATccT) (pp. 209-214). IEEE.
- [6] Yaşa, C., Mermer, S., Köksal, B., & Edizkan, R. (2020, October). Interactive Digital Notice Board. In 2020 Innovations in Intelligent Systems and Applications Conference (ASYU) (pp. 1-6). IEEE.
- [7] Ganesh, E. N. (2019). Implementation of digital notice board using raspberry pi and iot. *Oriental journal of computer science and technology*, 12(1), 14-20.
- [8] Kumar, V. S., Amirthasri, S., Ananya, M., & Esther, S. (2022, December). A Novel Method of IoT Based Smart Notice Board Using Raspberry Pi. In 2022 *International Conference on Computer, Power and Communications (ICCCP)* (pp. 60-64). IEEE.

# Redefining Attendance Systems with Facial Recognition

1<sup>st</sup> Dr. Priya Charles

Department of Electronics &  
Telecommunication

Dr. DY Patil Institute of Engineering  
Management and Research  
Akurdi, Pune, India  
hodetc@dypiemr.ac.in

2<sup>nd</sup> Ayush Prakash

Department of Electronics &  
Telecommunication

Dr. DY Patil Institute of Engineering  
Management and Research  
Akurdi, Pune, India  
ayushprakash483@gmail.com

3<sup>rd</sup> Prajay Kanade

Department of Electronics &  
Telecommunication

Dr. DY Patil Institute of Engineering  
Management and Research  
Akurdi, Pune, India  
prajaykanade2@gmail.com

4<sup>th</sup> Rohit Ghanekar

Department of Electronics &  
Telecommunication

Dr. DY Patil Institute of Engineering  
Management and Research  
Akurdi, Pune, India  
rohitghanekar13@gmail.com

5<sup>th</sup> Rishikesh Kumar

Department of Electronics &  
Telecommunication

Dr. DY Patil Institute of Engineering  
Management and Research  
Akurdi, Pune, India  
rishikesh.kumar4560@gmail.com

**Abstract**— Attendance is crucial for a student's career. Educational institutions monitor attendance to determine eligibility for exams. Traditional attendance tracking methods are time-consuming, so an intelligent attendance system is needed. The automation sector led the way in the idea of transitioning from traditional attendance systems to digital systems that use face detection and recognition algorithms. This methodology can address the issue of proxies and students being marked present despite the fact that they are not physically there. This article discusses an automated attendance management Computerized system that combines commonly available components to construct a portable computer that uses facial recognition technology for tracking student attendance. This approach is useful for both convenience and record-keeping.

**Keywords**— Facial Recognition, Face Detection, Realtime, Attendance Management System, Raspberry Pi.

## I. INTRODUCTION (HEADING 1)

A successful institution begins with student bonding and regular student attendance. Higher attendance means higher grades, higher retention, and a better teaching experience frequent absenteeism makes it difficult for teachers and students to develop strong relationships. Therefore, educational institutions must have a high quality attendance data, this data provides important information for research institutes to develop policies, programs, and practices to improve participation rates, to increase student attendance, many teachers give good grades to well-attended students. Maintaining attendance records is a crucial aspect of any educational institution, but attendance systems have not evolved much, yet many research institutions still use traditional handwritten attendance or use spreadsheets on their computers. This makes it difficult for teachers to track student attendance as well as progress in Education institutions, registering attendance using traditional methods is a tedious task. Additionally, faculty members must call each student's name directly to note attendance. This can take up to 5 minutes for the entire session, and you may see proxies. Facial recognition systems are becoming more popular in various organizations due to their distinct advantages over traditional attendance systems. Facial Recognition System monitors and maintains attendance via technology across various

organizations, this system consists of four stages it follows that are Database construction, face recognition, face recognition, presence update. Pictures of children in the class are used to build the database to identify the face. The system uses computer vision technology to identify and recognize a person's face and mark their presence by matching it with the person's information in a database. The intended objective of this system is to create an attendance system based on facial recognition technique.

## II. LITERATURE SURVEY

TABLE I. COMPARITIVE STUDY OF EXISTING SYSTEM

Sr.No	Year of Publication	Title	Mainly Used
1	2018	Class Attendance Management System Using Face Recognition	Local Binary Pattern algorithm is used for dividing the image into several parts. [1]
2	2019	Implementation of IOT based Attendance Management System on Raspberry Pi	Haar cascade classifier is used for detecting faces. Local binary pattern histogram (LBPH) and OpenCV is used for face recognition. [2]
3	2019	A. S. Hasban et al. Face recognition for Student Attendance using Raspberry	Face image is captured and the facial features are extracted. Then it is matched with the existing database. [3]
4	2020	Attendance System Based on Dynamic Face Recognition	Two different Type of CNN is used P-Net and R-Net. [4]
5	2020	IAAS IoT-Based Automatic Attendance System with Photo Face Recognition in Smart Campus	SRGAN Algorithm is used for enhancing the image and then training the model. [5]

Sr.No	Year of Publication	Title	Mainly Used
6	2018	Smart Attendance Monitoring System (SAMS)	Detect the face using Viola & Jones & correlation tracker from the dlib library. [6]
7	2019	Attendance system based on face recognition system using CNN-PCA method and real time camera	Hybrid feature extraction method using CNN-PCA. [7]
8	2020	Comparative analysis of facial recognition models using video for real time attendance monitoring system	Histogram Oriented Gradients (HOG), Viola-Jones (Haar Cascade), and Convolution Neural Network (CNN) Histogram Oriented Gradients (HOG). [8]
9	2020	Deep-learning based group-photo Attendance System using One Shot Learning	Multi Task Convolution Neural Network (MTCNN) for detection of faces inside the class & Siamese neural network. [9]
10	2019	Real-Time Smart Attendance System using Face Recognition Techniques	Principle Component Analysis (PCA) & Convolutional Neural Network (CNN). [10]
11	2020	Automated Attendance System Using OpenCV	For the face detection system it used a haarcascade and for face recognition, it used LBPH model. [11]
12	2020	Design of Attendance System Based on Face Recognition and Android Platform.	ADA Boost cascade classifier & Local Binary Pattern (LBP). [12]

III. BLOCK DIAGRAM & COMPONENTS

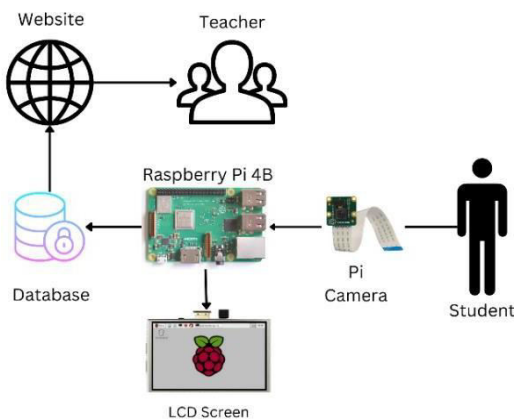

Fig. 1. Block Diagram of the Model

The components used in real-time classroom data display are listed below:

A. *Raspberry pi*

The Raspberry Pi 4b is a popular single-board computer that offers a high-performance and low-cost solution for various applications. It features a quad-core ARM Cortex-A72 processor, up to 8 GB of RAM, dual-band Wi-Fi, Bluetooth 5.0, Gigabit Ethernet, and two micro-HDMI ports. It can run the Raspberry Pi OS, a Linux-based operating system, and comes pre-installed with a number of apps and utilities. Other operating systems supported by the Raspberry Pi 4b are Ubuntu, Windows 10 IoT Core, and more. It also supports a wide range of accessories and add-ons, such as cameras, sensors, displays, and hats. It could also be used as a workstation, a media center, a robot controller, a smart home hub, and much more. The Raspberry Pi 4b is considered to be one of the most versatile, affordable computers and accessible device that enables anyone to learn, create and innovate.

The Raspberry Pi Foundation has developed a small computer Raspberry Pi 4B, Launched in June 2019 as a powerful version of Raspberry Pi 3B+. It has many aspects that set it apart from its predecessor. Equipped with a quad-core 64-bit CPU running at 1.8GHz, it is faster and more energy efficient than the previous generation. It has Ram Capacity up 8GB depending on your needs and affordability. It also supports dual displays with resolutions up to 4K, so we can multitask and play immersive games on twin monitors at the same time, it has two USB 3.0 ports and two USB 2.0 ports for data transfer, it can achieve data speeds up to 10x faster than before. Plus, it has wireless network connectivity and Bluetooth 5.0, and a Gigabit Ethernet port for high-speed internet connectivity.

B. *7-inch Waveshare LCD Screen*

The LCD screen is a high-quality display designed for use with various devices, including single-board computers like the Raspberry Pi. This LCD screen boasts a resolution of 1024x600 pixels and supports up to 10-finger touch control. The screen is also equipped with an HDMI interface and can be easily connected to a wide range of devices. In addition, the 7-inch Waveshare LCD screen features an QLED panel with a wide viewing angle of 170 degrees, ensuring clear and vivid images from almost any direction. The screen also supports other operating systems, including Raspbian, Ubuntu, and Windows 10 IoT, making it a versatile option for a wide range of projects. Overall, the 7 inch Waveshare LCD screen is a reliable and high-quality display is Perfect for a variety of applications including gaming, multimedia playback, and industrial control systems.

C. *USB Adapter*

A two-port USB adapter is a device that allows you to charge or connect two USB devices simultaneously through a single power outlet or USB port. It typically comes compact, making it easy to carry around, and can be plugged into any power outlet or USB port, such as on a laptop or a power bank. These adapters come in handy when you have multiple USB-powered devices that must be charged or connected at the same time in parallel. For example, smartphones, tablets, digital cameras, or Bluetooth headphones. By using a two-port USB adapter, you can be time-saving and hassle by charging both devices at once, rather than having to swap them out one at a time. Some two-port USB adapters also feature fast charging technology, which allows for a quicker charging

time than standard USB chargers can be particularly useful when you're in a rush or need to quickly power up your device before heading out. Overall, a two-port USB adapter is a wise investment and practical device that will help you stay connected and charged on the go.

D. Raspberry Pi Camera

A camera is a device that uses lenses and sensors to capture images and videos. They are typically embedded in electronic gadget's like smartphone, notebooks, tablets and surveillance cameras. It consists of parts like lens unit, image sensor, signal processor, memory chip, and connector. Camera size, resolution, quality, and features vary by application and device. The model used here is a 5MP Raspberry Pi camera. This module is ideal for small projects. It uses a specialized CSI interface specifically designed for connecting cameras. The CSI bus, which allows very high-speed data rates and only transfers pixel data. The sensor incorporates a fixed focus lens that helps capture images efficiently. As for image quality, the camera capture's still images at 2592 x 1944 pixels and also supports video up to 1080p30.

E. HDMI Cable

A camera is a device that uses lenses and sensors to capture images and videos. They are typically embedded in electronic gadget's like smartphone, notebooks, tablets and surveillance cameras. It consists of parts like lens unit, image sensor, signal processor, memory chip, and connector. Camera size, resolution, quality, and features vary by application and device. The model used here is a 5MP Raspberry Pi camera. This module is ideal for small projects. It uses a specialized CSI interface specifically designed for connecting cameras. The CSI bus, which allows very high-speed data rates and only transfers pixel data. The sensor incorporates a fixed focus lens that helps capture images efficiently. As for image quality, the camera capture's still images at 2592 x 1944 pixels and also supports video up to 1080p30.

IV. SYSTEM REQUIREMENTS

- 4Gb Minimum RAM
- Minimum 16Gb ROM
- 720p, 5Mp Camera
- 756 X 600 minimum Resolution

V. SYSTEM FLOW

The very first step is to start taking a picture of a person's face. Images are captured using a camera connected to the attendance system, and the camera can be placed in a fixed position or moved to capture the image. Captured images are pre-processed to improve image quality and extract facial features. Pre-processing can include image filtering, normalization, and resizing. The pre-processed image is analysed to identify human faces in the image. This is typically done using facial recognition algorithms that identify the location and size of faces. Facial include the location of the eyes, nose, mouth, and other facial features. The extracted features are compared to known facial features in the database for identifying the person. To do this, the similarities of the extracted features are compared with known facial features. If the similarity exceeds a certain threshold, the person's identity is confirmed. Once an individual's identity is recognized and verified, the system marks that person's presence. This can be done by updating the attendance database with the person's

timestamp and presence status. The system records attendance data and generates reports for further analysis. With the info on Attendance data we could create reports such as daily attendance reports, monthly attendance reports, and attendance summaries. These reports would be used for performance evaluation, and other purposes. Mostly, facial recognition based computerized attendance systems help organizations streamline attendance management processes, improve accuracy, and reduce administrative overhead. It also helps ensure that attendance records are secure, reliable, and accessible when needed.

VI. METHODOLOGY

A. Attendance Software

Faces detection: Using computer vision techniques like Haar cascades, neural networks, or a combination of the two, the software first identifies and pinpoints faces in an image or video frame. Facial Position: In order to assure consistency in the facial traits that are retrieved, the software then aligns the identified faces to a standard orientation and size. Feature Extraction: The software extracts unique features of the human face Like segregation of eyes, nose and mouth the shape of the jaw line and the curve of the eyebrows. That is usually done using deep learning algorithms such as convolutional neural networks. Face Matching: To find a match, the extracted features are compared to a database of previously registered faces. A resemblance between the retrieved characteristics and the features of the registered faces is computed during this phase. The face is regarded as a match if the similarity score exceeds a predetermined threshold. Attendance Recording: When a match is made, the attendance programme logs the person's time and presence. Constant Learning: To increase the software's accuracy and robustness over time, it is continuously taught with fresh data.

Faces in the image are detected by the Hair Cascade classifier. This method was proposed by Paul Viola and Michael Jones. Haar cascade classifier is feasible in OpenCV source's face, eyes, smile, etc. The hair cascade classifier mainly segregate faces accordingly for edge and corner functions. This classifier have being high Detection accuracy and low false positive rate.

Equation (1) is Haar cascade classifier Equation

$$LBP(x_n, y_n) = \sum_{p=0}^{p-1} 2^p S(i_p - i_c) \tag{1}$$

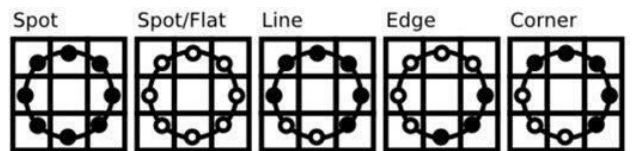

Fig. 2. Variable neighborhood radius for extracting features

For a specific point, (xn, yn) the position of the neighbour (xp, yp) can be calculated by applying the following equation

Equation (2) is Position of Neighbour

$$x_p = x_c + R \cos\left(\frac{2\pi}{p}\right) \quad (2)$$

1) Pose estimation: People move and look different direction in front of the real-time video camera can have one Wide head poses oriented at various angles. It is crucial to have the least rotated face possible, hence this attribute should be considered while evaluating face quality. We used 68 face landmark to determine the coordinates of the tip of nose and the point between the eyebrows. For  $(x_1, y_1)$  and  $(x_2, y_2)$  such a point, the yaw angle is calculated using:

Equation (3) is Pose Estimation

$$yaw = \text{abs}(\arctan2(y_2 - y_1, x_2 - x_1)) \quad (3)$$

2) Sharpness: The image is likely to be fuzzy in real time video continuousness because the face is moving. As a result, it is crucial to incorporate this feature when assessing facial quality.

Equation (4) is Sharpness

$$\text{Sharpness} = \sum_{(i,j) \in \mathcal{U}(x,y)} (\Delta I(i,j) - \overline{\Delta I})^2 \quad (4)$$

3) Image size or resolution: employing face tracking as long as the face is in the frame, the webcam will track it. But when face is moved more distant from the camera, it gets gradually smaller. So, this facial attribute must be present quality assessment. The location of an individual's face's eye corners. Left eye corner  $(x_L, y_L)$  and right eye coordinates Corner  $(x_R, y_R)$ . The separation between them is given by:

Equation (5) is image size

$$\text{Resolution} = \sqrt{(x_L - x_R)^2 + (y_L - y_R)^2} \quad (5)$$

4) Brightness: There is a good chance that lightning conditions will change in real-time operation such as surveillance cameras. On lighter-colored faces as opposed to darker-colored faces, local feature extraction is simpler to use. Consequently, it is essential to provide this feature in face quality assessment. To obtain this parameter, we calculated the average of each all the intensities of various channels (R, G, B) present in the image.

Equation (6) is image size

$$\text{Brightness} = (R + G + B)/3 \quad (6)$$



Fig. 3. Face Recognition From database

Fig. 4. Data of Marked attendance users

### B. Authentication for Website

The login process is a common feature in many websites and involves allowing users to access their accounts by providing their login credentials (usually a username and password). Here's a basic overview of how the login process works on a website. The user inputs their login information by going to the login page and entering their credentials for logging in. User credentials are verified by a website: After the user provides their credentials, the website verifies their validity by comparing them to a database of registered users. Access is given to the user: The website gives users access to their accounts and any associated features or material if their login information are legitimate. A session is established: The website generates a session that identifies the user and saves their login status in order to keep the user's access. Somebody logs off: The user can log out to end their session and revoke access once they have completed using the website. Once the user is logged into the attendance management website, the user can download the csv file for the desired date.

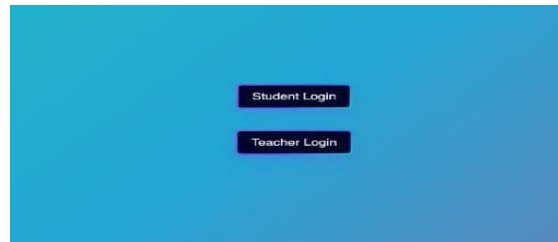

Fig. 5. Working Webpage

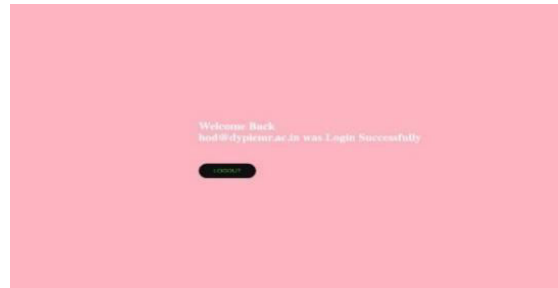

Fig. 6. Login Successful Screen

## VII. APPLICATIONS

Here are some applications of face recognition computerized based attendance system in today's world:

- Education sector: It is useful for various educational institutes like schools, colleges, and universities to automatically manage student attendance.
- Corporate sector: It is suitable for Companies to manage employee presence at the workplace and reduce administrative workload.
- Healthcare sector: Hospitals and healthcare facilities can use this attendance systems to observe the presence of healthcare professionals, nurses, and support staffs.
- Event management: Event managers can use these systems to manage attendee registration, track attendee movement, and ensure security during the event.
- Government agencies: Government agencies can use this system to track employee attendance, monitor visitor entry and exit, and enhance security measures.

## VIII. RESULTS

A Raspberry Pi computer with a camera module attached to it would most likely be used in a face recognition computerized based attendance system. Machine learning techniques would be used by the system to find and identify the individuals in field of view of the camera. The system would then record each person's attendance using their recognized faces. Several variables can impact a face recognition computerized based attendance system's accuracy, including the caliber of the camera, the illumination, the efficiency of the detection system and identification algorithms, and the quantity of the face database used to train the system. The system should also handle an array of situations, such as when a camera is viewing many persons or when someone is wearing a mask. Essentially, the effectiveness of the face recognition computerized attendance system powered by a Raspberry Pi would depend on the implementation's details and the caliber of the hardware and software employed. A facial recognition computerized attendance system built on a Raspberry Pi can be efficient and effective method to record attendance with good optimization.

## IX. CONCLUSION

The face recognition computerized based attendance system project is a highly effective solution that can change attendance management in various organizations, such as schools, universities, and companies. This project is a step forward in the automation of administrative tasks and is an excellent example of how technology can streamline and optimize everyday operations. This system uses advanced using facial identification programme to recognize and authenticate the identity of individuals in real-time. It has numerous benefits, including eliminating the necessity of taking manual attendance as well as, reducing organizations workload, minimizing errors, improving accuracy and it can also generate reports, analyze Statistics regarding attendance and offer insights that can help improve attendance

management. Overall, the face recognition computerized based attendance system is a highly effective solution which solves existing manual system problems. We used the concept of facial recognition to mark the presence of students and improve our system. Our project is innovative in a way such that It uses the dlib library which is much more accurate than existing models. Our system also stores data locally and use an authentication system for data access.

## References

- [1] O. A. R. Salim, R. F. Olanrewaju and W. A. Balogun, "Class Attendance Management System Using Face Recognition," 2018 7th International Conference on Computer and Communication Engineering (ICCCE), 2018, pp. 93-98, doi: 10.1109/ICCCE.2018.8539274
- [2] V. Ruhitha, V. N. Prudhvi Raj and G. Geetha, "Implementation of IOT based Attendance Management System on Raspberry Pi," 2019 International Conference on Intelligent Sustainable Systems (ICISS), 2019, pp. 584-587, doi: 10.1109/ISS1.2019.8908092.
- [3] A. S. Hasban et al., "Face recognition for Student Attendance using Rasperry Pi," 2019 IEEE Asia-Pacific Conference on Applied Electromagnetics (APACE), 2019, pp. 1-5, doi: 10.1109/APACE47377.2019.9020758.
- [4] S. Huang and H. Luo, "Attendance System Based on Dynamic Face Recognition," 2020 International Conference on Communications, Information System and Computer Engineering (CISCE), 2020, pp. 368-371, doi: 10.1109/CISCE50729.2020.00081.
- [5] J. P. Jeong, M. Kim, Y. Lee and P. Lingga, "IAAS: IoT-Based Automatic Attendance System with Photo Face Recognition in Smart Campus," 2020 International Conference on Information and Communication Technology Convergence (ICTC), 2020, pp. 363-366, doi: 10.1109/ICTC49870.2020.9289276.
- [6] S. Bhattacharya, G. S. Nainala, P. Das and A. Routray, "Smart Attendance Monitoring System (SAMS): A Face Recognition Based Attendance System for Classroom Environment," 2018 IEEE 18th International Conference on Advanced Learning Technologies (ICALT), 2018, pp. 358-360, doi: 10.1109/ICALT.2018.00090.
- [7] E. Winarno, I. Husni Al Amin, H. Februariyanti, P. W. Adi, W. Hadikurniawati and M. T. Anwar, "Attendance System Based on Face Recognition System Using CNN-PCA Method and Real-time Camera," 2019 International Seminar on Research of Information Technology and Intelligent Systems (ISRITI), 2019, pp. 301-304, doi: 10.1109/ISRITI48646.2019.9034596
- [8] P. Patil and S. Shinde, "Comparative analysis of facial recognition models using video for real time attendance monitoring system," 2020 4th International Conference on Electronics, Communication and Aerospace Technology (ICECA), 2020, pp. 850-855, doi: 10.1109/ICECA49313.2020.9297374.
- [9] A. Bhat, S. Rustagi, S. R. Purwaha and S. Singhal, "Deep-learning based group-photo Attendance System using One Shot Learning," 2020 International Conference on Electronics and Sustainable Communication Systems (ICESC), 2020, pp. 546-551, doi: 10.1109/ICESC48915.2020.9155755.
- [10] S. Sawhney, K. Kacker, S. Jain, S. N. Singh and R. Garg, "Real-Time Smart Attendance System using Face Recognition Techniques," 2019 9th International Conference on Cloud Computing, Data Science & Engineering (Confluence), 2019, pp. 522-525, doi: 10.1109/CONFLUENCE.2019.877693
- [11] N. Gupta, P. Sharma, V. Deep and V. K. Shukla, "Automated Attendance System Using OpenCV," 2020 8th International Conference on Reliability, Infocom Technologies and Optimization (Trends and Future Directions) (ICRITO), 2020, pp. 1226-1230, doi: 10.1109/ICRITO48877.2020.9197936.
- [12] X. Bai, F. Jiang, T. Shi and Y. Wu, "Design of Attendance System Based on Face Recognition and Android Platform," 2020 International Conference on Computer Network, Electronic and Automation (ICCNEA), 2020, pp. 117-121, doi: 10.1109/ICCNEA50255.2020.00033

# Artificial Intelligence in Cyber Security

Aniket D. Karse

Department of Computer Science & Engineering

Sipna College of Engineering & Technology

Sant Gadge Baba Amravati University  
Amravati, Maharashtra, India  
aniketkarse712@gmail.com

Ravina H. Popli

Department of Computer Science & Engineering

Sipna College of Engineering & Technology

Sant Gadge Baba Amravati University  
Amravati, Maharashtra, India  
ravinapopli2430@gmail.com

Kshitij U. Deshmukh

Department of Computer Science & Engineering

Sipna College of Engineering & Technology

Sant Gadge Baba Amravati University  
Amravati, Maharashtra, India  
kshitijdeshmukh18@gmail.com

Nachiket V. Yawalkar

Department of Computer Science & Engineering

Sipna College of Engineering & Technology

Sant Gadge Baba Amravati University  
Amravati, Maharashtra, India  
yawalkarnachiket@gmail.com

## ABSTRACT

In the digital age, cyber security has grown to be a big concern. Data breaches, identity theft, captcha cracking, and other similar issues frequently harm millions of people as well as organizations. Inventing the proper controls and processes and putting them into practice with exacting perfection to combat cyber-attacks and crimes has always been a struggle. With recent advances in artificial intelligence, the risk of cyberattacks and crimes has increased rapidly. Almost all areas of science and engineering have used it. AI has sparked a revolution in fields ranging from healthcare to robotics. Cybercriminals couldn't resist this ball of fire, therefore the "usual" cyberattacks have evolved into "intelligent" cyberattacks.

**Keywords— Artificial Intelligence, Cyber Security, Cyber Attacks.**

## I. INTRODUCTION

Cyber security plays a crucial role in safeguarding sensitive information such as personal, governmental, industry, and protected health data from cyber attackers who aim to cause harm. Cyber-attacks can result in disabling the target computer, taking services offline, or gaining unauthorized access to the target's data. To combat these threats, many organizations have turned to artificial intelligence (AI) tools, such as machine learning, to enhance their security posture and minimize breach risks. This is especially important as the sophistication of cyber-arms and malware has increased significantly in recent years. For instance, the Conficker virus infected key devices and computers across various organizations, including the French Navy, UK Defense Ministry, and German armed forces, causing significant disruptions. To counter such incidents, the adoption of AI techniques and knowledge-intensive tools is vital in developing new defensive strategies, such as dynamic installation of secure perimeters and automated responses to network attacks.

## II. LITERATURE REVIEW

Malware detection: "Using Machine Learning Techniques for Malware Detection" by S. Garcia, J. S. Saiz, and J. M. Garcia, in *Expert Systems with Applications*, 2014. This study used machine learning algorithms to analyze the behavior of malware and identify patterns that can help detect new strains of malware.[11]

Intrusion detection: "An Intrusion Detection System Using Machine Learning Algorithms" by A. Singh and A. K. Sharma, in *Procedia Computer Science*, 2018. This study used machine learning algorithms to identify patterns of suspicious behavior, such as repeated failed login attempts or unusual data transfer activities.

Threat intelligence: "Cyber Threat Intelligence: From Collection to Exploitation" by R. M. Lee, in CRC Press, 2017. This book provides an overview of how AI can be used to analyze large volumes of data from various sources to identify potential threats.

Vulnerability management: "Artificial Intelligence and Machine Learning for Cybersecurity Vulnerability Management: State of the Art and Future Directions" by Y. Li, M. Li, and Y. Jin, in *Computers & Security*, 2019. This study used machine learning algorithms to analyze data from vulnerability scans and prioritize vulnerabilities based on their severity and potential impact.

Behavioral biometrics: "A Survey of Behavioral Biometrics: Approaches and Applications" by A. Al-Fuqaha, M. Guizani, and M. Mohammadi, in *IEEE Communications Surveys & Tutorials*, 2015. This study discussed how AI can be used to analyze patterns of user behavior and detect anomalies that may indicate a security threat.

Cyber threat hunting: "Cyber Threat Hunting: AI, Machine Learning, and Big Data Analytics" by G. J. Ahn, in CRC Press, 2020. This book provides an overview of how AI can be used to analyze large volumes of data from various

sources to identify potential threats before they can cause damage.

### III. METHODOLOGY

We conducted a comprehensive search across Scopus, Web of Science, ACM Digital Library, IEEE Xplore, and Google Scholar to explore the intersection between cybersecurity and AI. Our search used relevant keywords and filtered results to include papers published within the past four years and those with more than five citations or innovative approaches.[3] We excluded irrelevant papers and identified those with pertinent information through examination of abstracts and conclusions.[5] Our literature review aimed to analyze gaps in research, develop an architecture for future studies, synthesize the impact of AI on security, and evaluate existing and proposed methods.

### IV. CYBER SECURITY

Cybersecurity is essential in our increasingly interconnected world, where cyber-attacks and threats are on the rise. It refers to the protection of computer systems, networks, and other devices from unauthorized access, theft, damage, and exploitation of sensitive information.[2] The following are some of the different types of cyber threats that can pose a significant risk to individuals and organizations:

1. **Malware:** Malware is malicious software that can infect a computer or device and cause damage to data or disrupt normal system operations. Examples of malware include viruses, worms, Trojans horse.
2. **Phishing:** Phishing involves an attacker attempting to deceive users into providing sensitive information, such as credit card details, passwords, or other personal data, by posing as a trustworthy entity in an email or other communication.
3. **Denial-of-service attacks (DoS):** Attacks known as denial-of-service (DoS) are intended to saturate a network or website with traffic, rendering it inaccessible to authorized users.
4. **MitM attack:** Man-in-the-middle attacks occur when an attacker intercepts communication between two parties and can eavesdrop on, manipulate, or alter the messages being sent or receive.
5. **SQL injection:** An SQL injection attack is when an attacker exploits vulnerabilities in a website or application's database to execute unauthorized commands, steal data, or modify data.
6. **Ransomware:** Ransomware is a type of malware that encrypts a user's files or data and demands payment in exchange for the decryption key.
7. **Advanced persistent threats (APTs):** APTs are long-term, targeted attacks designed to infiltrate a network, steal sensitive information, and remain undetected for as long as possible.
8. **Zero-day attacks:** Zero-day attacks are when an attacker exploits a vulnerability in a system or software before it is discovered and patched.
9. **Insider threats:** Insider threats refer to attacks or data breaches that originate from within an organization,

such as an employee stealing sensitive data or intentionally damaging systems.[1]

Each of these cyber threats poses unique risks and requires a specific approach to mitigate the damage caused. Organizations must implement a comprehensive cybersecurity strategy that includes proactive measures such as employee training, network monitoring, and regular system updates, as well as reactive measures such as incident response plans and disaster recovery plans to minimize the impact of a cyber-attack.[7]

### V. NEED OF CYBER SECURITY.

In coming years, it is estimated that cyber-crime will cost businesses around the world \$10.5 trillion loss yearly, up from \$3 trillion in 2015. According to Cybersecurity experts, cybercrime constitutes the largest ever transfer of economic wealth, growing at a rapid pace of 15% annually.[1]

Cyberattacks can have a variety of effects on a company, ranging from modest operational delays to significant financial losses. Regardless of the kind of cyberattack, every effect comes at a cost, whether it be monetary or otherwise. Even weeks or months after the cybersecurity incident, the effects may still be felt by the company. Following are five areas where businesses may face difficulty:

- Business continuity problems
- Reputation damage
- Loss of productivity
- Legal liability
- Financial losses[4]

Ransomware attacks are getting more frequent and problematic. Every 40 seconds at the end of 2016, a company was the target of a ransomware attack and in 2021, this increased to every 11 seconds. This cyberattack takes place when malicious software is used to prevent the victim from accessing a computer system or data until the criminal demands ransom.[6]

Certain industries are more vulnerable to cyberattacks based on their business practices. While any sector can experience a data breach, those that have a direct impact on consumers daily lives are particularly vulnerable. [9]

Hackers often target businesses that store sensitive user data or personally identifiable information. The following types of businesses and organizations are especially at risk of cyberattacks:

- **Banks and other financial institutions:** Store personal client or customer data as well as credit card and bank account information.
- **Healthcare facilities:** Data repositories for clinical research data, medical records, and patient

information such as social security numbers, billing addresses, and insurance claims.

- Corporations: Possesses comprehensive data, including product conceptions, intellectual property, marketing plans, client and employee databases, contract agreements, client pitches, and more.
- Higher education: Maintain records of enrollment information, academic research, financial transactions, and personally identifiable data such as names, addresses, and billing information.

The requirement for cybersecurity stems from our growing reliance on technology and the internet in both our personal and professional spheres.[10] As our interconnectedness expands, so does the risk of cyber-attacks and threats.

The following list of factors illustrates why cybersecurity is crucial:

- Protection of sensitive information: Cybersecurity is necessary to protect sensitive information such as financial information, personal data, trade secrets, and intellectual property from unauthorized access, damage, or theft.
- Compliance with regulations: Many industries and organizations are required to comply with specific regulations and standards to ensure the privacy and security of their data. Failure to comply with these regulations can result in reputational damage and severe penalties.
- Mitigation of financial losses: Cyber-attacks can result in significant financial losses due to theft of funds, damage to systems and infrastructure, and the cost of remediation.
- Preservation of reputation: A cyber-attack can damage an organization's reputation and erode trust with its customers, partners, and stakeholders.
- Protection of critical infrastructure: Cybersecurity is crucial in protecting critical infrastructure, such as transportation systems, power grids, and healthcare facilities, which can have severe consequences if compromised.[8]

Overall, cybersecurity is necessary to ensure the availability, confidentiality and integrity of data and systems, as well as to maintain the trust and confidence of customers and stakeholders.[7]

## VI. ARTIFICIAL INTELLIGENCE

Artificial intelligence (AI) is increasingly becoming an integral part of today's world, permeating various aspects of our daily lives and transforming numerous industries and businesses. Here are some key areas where AI is making a significant impact:

1. Automation: AI is automating repetitive and mundane tasks across industries, such as manufacturing, customer service, logistics, and data entry. This has led to improved productivity, increased efficiency and reduced costs.

2. Personal assistants: Virtual personal assistants, such as Siri, Alexa, and Google Assistant, are powered by AI and natural language processing, allowing users to interact with their devices using voice commands for tasks like scheduling appointments, setting reminders, and playing music.

3. Healthcare: AI is revolutionizing healthcare with applications in medical diagnosis, drug discovery, personalized treatment plans, and telemedicine. AI algorithms can analyze medical data, including electronic health records (EHRs), medical images, and genetic data, to assist in accurate diagnosis and treatment decisions.

4. Autonomous vehicles: AI is driving the development of self-driving cars, drones and trucks. AI algorithms process data from sensors and cameras to enable autonomous vehicles to navigate, recognize traffic patterns, and make decisions in real-time.

5. Finance: AI is transforming the finance industry with applications in fraud detection, risk assessment, algorithmic trading, and personalized financial advice. AI-powered chatbots are also being used for customer service and support in the financial sector.

6. Marketing and advertising: AI is being used in marketing and advertising to analyze consumer data, personalize content, and optimize campaigns. Users can receive personalized product recommendations from recommendation engines powered by AI based on their tastes and behavior.

7. Natural language processing: AI is advancing natural language processing (NLP) capabilities, enabling machines to understand, interpret, and respond to human language. NLP is used in applications such as language translation, sentiment analysis, and speech recognition.

8. Cybersecurity: AI is used in cybersecurity for threat detection, malware analysis, and user behavior analytics. AI algorithms can analyze vast amounts of data to identify patterns that may indicate cyber threats and help organizations respond to attacks more swiftly.

9. Social-media: AI is used in social media for sentiment analysis, content recommendation, and social listening. AI algorithms can analyze social media data to identify trends, patterns and sentiments, helping businesses understand customer preferences and behavior.

10. Education: AI is being used in education for personalized learning, automated grading and intelligent tutoring systems. AI-powered platforms can adapt learning materials to individual learners needs, providing tailored educational experiences.[1]

These are just a few examples of how AI is being used in today's day and age. As AI continues to advance, it is expected to have a profound impact on various businesses and industries in reshaping the way we live and work. However, it is important to consider ethical considerations, such as transparency, accountability and fairness, as AI continues to evolve and become more widespread.[3]

## VII. THE PART PLAYED BY AI IN ENHANCING CYBER SECURITY

AI plays a crucial role in contemporary cyber security practices, utilizing algorithms and machine learning techniques to analyze extensive data and identify potential threats. Traditional cyber security methods often struggle to handle the volume and complexity of modern cyber-attacks, but AI-based solutions have the capability to detect and respond to emerging threats in real-time.[7]

The integration of AI in cyber security brings numerous benefits, such as the ability to identify patterns, automate repetitive tasks, and improve accuracy.[3] For instance, AI-powered Security Information and Event Management (SIEM) systems utilize machine learning algorithms to detect and alert security teams to potential threats. Other examples include AI-powered antivirus software and intrusion detection systems.

Furthermore, AI possesses the ability to identify and respond to emerging cyber threats that may evade detection by conventional security methods. For example, cyber attackers may take advantage of zero-day vulnerabilities before they are identified and patched by security experts. Nevertheless, AI-powered systems can analyze patterns in real-time, allowing them to promptly detect and mitigate these vulnerabilities before cyber attackers can exploit them.

Moreover, the utilization of AI-based security solutions can enhance organizations cyber security posture by improving their incident response capabilities. With the aid of AI-based tools, security teams can automate tasks such as identifying threats, investigating incidents, and responding to them, resulting in minimized damage to the organization and reduced response time.

In summary, the role of AI in cyber security is vital and is anticipated to grow in significance in the future as cyber threats continue to evolve in future. AI-powered solutions can offer organizations a robust defense against cyber-attacks, enabling them to safeguard their data, assets, and reputation in today's ever-changing digital landscape.[7]

## VIII. AI TO THE RESCUE

Based on a review of articles on the intersection of AI technologies and cybersecurity, it is evident that AI has numerous significant applications in this field. One of the primary ways AI is being used is in perimeter shooting neural networks. Additionally, AI-based approaches have shown great promise in efficiently overcoming various cybersecurity challenges. In cybersecurity decision-making

processes, the utilization of comprehensive information is crucial, and AI-based decision assistance can play a crucial role in addressing this challenge.[5] AI has seen the establishment of a wide range of approaches for resolving complex situations that typically require human intelligence. Many of these strategies have reached maturity, with specific algorithms based on these approaches now available. Some methods have become so widely used that they are no longer considered part of artificial intelligence, such as data mining algorithms that have emerged from AI's learning subfield.[9]

It is impossible to provide a comprehensive overview of all possible AI approaches in a short survey. However, we have divided approaches and architectures into various categories, such as artificial neural, expert systems, smart agents, quest, computer education, data gathering, and constraint resolution, and identified the cyber protection approaches that correspond to each category. This survey does not cover machine vision, robotics, and natural language comprehension, which are particular AI applications.[6] While robots and machine vision may have incredible military capabilities, there is nothing uniquely related to cybersecurity in those areas.

- a) Artificial Intelligence continues to increase in intelligence.
- o Artificial Intelligence technology is named so because of its inherent ability to continuously improve network security. By leveraging machine learning and deep learning, AI can better understand an organization's network behavior over time. It recognizes patterns within the network and clusters them together to detect any deviations or potential security incidents in normal traffic. After analyzing the traffic, it promptly responds to any threats.
- b) The utilization of Artificial Intelligence aids in the detection of unidentified threats.
- o With the rise of sophisticated social engineering and increasing malware attacks, it is crucial to adopt modern solutions to prevent new attacks from causing damage to computer systems. To detect and prevent unknown threats from compromising an organization's network infrastructure, the integration of artificial intelligence in cybersecurity is proving to be a highly effective combination of security technologies.
- c) Artificial Intelligence is capable of processing large volumes of data.
- o Artificial intelligence is a valuable tool in identifying potential threats that may be disguised as normal activities. Its automated nature allows it to efficiently read and analyze large volumes of data to detect any potential dangers. A technology that uses AI, known as a residential proxy, can assist in the transfer of data and also aid in threat detection by identifying any malicious activity within the traffic.

- d) The management of vulnerabilities can be improved with the use of Artificial Intelligence.
- o By analyzing computer systems and business networks, Artificial Intelligence can identify weaknesses and help businesses focus on more crucial security tasks, thereby decreasing the workload and increasing problem-solving abilities by multiple times. As compared to cybersecurity personnel, AI is faster and can quickly assess systems, making it possible to manage vulnerabilities and secure business systems in a timely manner.[2]

## IX. CHALLENGES

The integration of Artificial Intelligence (AI) into cyber security presents numerous challenges. One significant issue is the lack of transparency in AI algorithms, which makes it challenging to comprehend and elucidate the decision-making process. This opacity can lead to doubts about the reliability of the AI system's actions and recommendations.

Another challenge is the susceptibility of AI systems to manipulation or deception by attackers, resulting in inaccurate threat detection outcomes. Adversarial attacks have become increasingly sophisticated, posing a threat even to advanced AI systems.

Furthermore, the scarcity of qualified personnel to manage and maintain AI systems can pose a problem. Continuous monitoring and updating of AI systems are essential to ensure their efficacy against emerging threats.

Lastly, ethical concerns arise with the use of AI in cyber security. There is a risk of bias in AI systems, leading to discriminatory practices. Additionally, there are concerns about the malicious use of AI, such as creating highly personalized and targeted attacks.

In summary, while the implementation of AI in cyber security offers many advantages, it also presents challenges such as lack of transparency, susceptibility to manipulation, shortage of skilled personnel, and ethical concerns. Addressing these challenges is crucial for responsible and effective integration of AI in the field of cyber security.[3]

## X. CONCLUSION/RESULT

In conclusion, the incorporation of AI in the field of cyber security has brought about a revolutionary impact on combating cyber-attacks and threats. It has empowered

organizations with advanced capabilities for detecting and preventing threats, securing systems and effectively managing vulnerabilities. However, there are challenges that require more attention, including the lack of transparency in AI algorithms, the potential for manipulation by malicious actors, ethical concerns and shortage of skilled personnel. Continuous research and development in AI for cyber security are imperative to tackle these challenges. Overall, the potential of AI to transform cyber security is immense, and its continued integration will play a crucial role in protecting the digital world, in this digital era.

## REFERENCE

- [1] *Use of Artificial Intelligence Techniques / Applications in Cyber Defense*. (n.d.). Retrieved 14 August, 2020, from [https://www.researchgate.net/publication/333477899\\_Use\\_of\\_Artificial\\_Intelligence\\_Techniques\\_Applications\\_in\\_Cyber\\_Defense](https://www.researchgate.net/publication/333477899_Use_of_Artificial_Intelligence_Techniques_Applications_in_Cyber_Defense).
- [2] Ahmad, I., Abdullah, A. B., & Alghamdi, A. S. (2009). Application of artificial neural network in the detection of DOS attacks. *SIN'09 - Proceedings of the 2nd International Conference on Security of Information and Networks*, 229–234. <https://doi.org/10.1145/1626195.1626252>.
- [3] Bai, J., Wu, Y., Wang, G., Yang, S. X., & Qiu, W. (2006). A novel intrusion detection model based on multi-layer self-organizing maps and principal component analysis. *Lecture Notes in Computer Science (Including Subseries Lecture Notes in Artificial Intelligence and Lecture Notes in Bioinformatics)*, 3973 LNCS, 255–260. [https://doi.org/10.1007/11760191\\_37](https://doi.org/10.1007/11760191_37).
- [4] Bitter, C., North, J., Elizondo, D. A., & Watson, T. (2012). An introduction to the use of neural networks for network intrusion detection. *Studies in Computational Intelligence*, 394, 5–24. [https://doi.org/10.1007/978-3-642-25237-2\\_2](https://doi.org/10.1007/978-3-642-25237-2_2).
- [5] Carrillo, F. A. G. (2012). ¿Can Technology Replace the Teacher in the Pedagogical Relationship with the Student? *Procedia - Social and Behavioral Sciences*, 46, 5646–5655. <https://doi.org/10.1016/j.sbspro.2012.06.490>.
- [6] Chang, R. I., Lai, L. Bin, & Kouh, J. S. (2009). Detecting network intrusions using signal processing with query-based sampling Filter. *Eurasip Journal on Advances in Signal Processing*, 2009. <https://doi.org/10.1155/2009/735283>.
- [7] Chatzigiannakis, V., Androulidakis, G., & Maglaris, B. (2004). A Distributed Intrusion Detection Prototype using Security Agents. *HP OpenView University Association, June 2014*.
- [8] Chmielewski, M., Wilkos, M., & Wilkos, K. (2010). Building a multiagent environment for military decision support tools with semantic services. *Lecture Notes in Computer Science (Including Subseries Lecture Notes in Artificial Intelligence and Lecture Notes in Bioinformatics)*, 6070 LNAI(PART 1), 173–182. [https://doi.org/10.1007/978-3-642-13480-7\\_19](https://doi.org/10.1007/978-3-642-13480-7_19).
- [9] Corral, G., Llull, U. R., Herrera, A. F., Management, H., Ignasi, S., & Llull, U. R. (2007). Innovations in Hybrid Intelligent Systems {--} Proceedings of the 2nd International Workshop on Hybrid Artificial Intelligence Systems (HAIS'07). 44/2008(June 2014). <https://doi.org/10.1007/978-3-540-74972-1>.
- [10] Feyereisl, J., & Aickelin, U. (2009). *Self-Organising M Aps*. August, 1–30.
- [11] "Using Machine Learning Techniques for Malware Detection" by S. Garcia, J. S. Saiz, and J. M. Garcia, in *Expert Systems with Applications*, 2014

# Cybercrime and Law Enforcement: A Review of International Approaches

Utkarsh Varshney  
 Dept. of Computer Science & Technology  
 Central University of Punjab  
 Bathinda, India  
 uvtkarsh11@gmail.com

Dhirendra Singh Mahra  
 Dept. of Computer Science & Technology  
 Central University of Punjab  
 Bathinda, India  
 dhirendra.mahra@gmail.com

**Abstract**— The continuous expansion in the number of Internet users and e-commerce has an exponential impact on the rate of cyber crimes. Cybercrime is not just limited to any single entity, as it includes a variety of attacks being performed by many malicious actors. The paper focuses on studying and analyzing various approaches that are globally being used by different countries to combat cyber criminals, such as Budapest Convention. Moreover, there is still a need for comprehensive answers to the world's increasing security problems in this digital age. As cyberspace security initiatives are primarily proactive, there is a strict need for Law enforcement to keep up with the rate of technological development, and international cooperation is of utmost necessity to prevent cybercrime effectively.

**Keywords**— Cybercrime, Law Enforcement, Cybersecurity, Cyberspace, Globalization

## I. INTRODUCTION

The Internet is essential in our daily life in the digital era. Internet use is expanded from social media to online shopping, live streaming and many other things. Access to the Internet is effortless for users because of the increasing smartphone and high-speed Internet. Today, billions of people are more connected than ever with technology. According to the Data report, around 5.16 billion internet users will be worldwide in 2023. The number of users, who now number 98 million, increased by 1.9% annually over the last 12 months, and they typically use the internet for at least 6 hours per day [1].

The rise of new e-commerce and the rapid development of computer connectivity have required national governments and international organizations to regulate and guarantee security on the "information superhighway." The Internet has transformed how we conduct business, removed earlier barriers to contact, and compressed our perceptions of time and space. Although digital technology has greatly benefited society, it has raised domestic and international concerns. Criminal networks and individual criminals have grown in power to take advantage of weaknesses in the "modern" economy take the edge of weaknesses in the "modern" economy, criminal networks and individual criminals have grown in power. All fronts must continue to focus on the function of information and technology in creating national assets. Unsurprisingly, efforts to secure cyberspace have been reactive rather than proactive. Rather than being proactive, efforts to safeguard cyberspace have been reactive, and genuinely global solutions to security issues in the digital age have yet to materialize. Although considerable progress has been made within and across the country to improve police response to cybercrime, Law enforcement will still need help keeping up with the rate of technological development. However, the impression of what

can be accomplished locally and internationally has been profoundly altered by the startling acceleration of international law enforcement cooperation in reaction to cybercrime and other threats. Although encouraging progress has been made, it should be viewed as only the beginning. The adage "think globally, act locally" mainly concerns cybercrime prevention.

### A. Defining Cybercrime

Cybercrime is the term for illegal operations that include computers, the Internet, or other digital technology. Hacking, phishing, identity theft, cyberbullying, and disseminating malware or viruses are just a few unlawful behaviors under this umbrella. Cybercrime can be perpetrated by one person, a group, a nation-state, or even an organization [2]. Cybercrime can be classified into several categories, including:

1) *Cyber Espionage*: A cyberattack against a competing business or governmental body is known as cyber espionage, often called cyberespionage. Cyber espionage, commonly called cyber spying, aims to provide the attacker with information that offers them a competitive edge over other organizations or governments. The perpetrators of cyber espionage frequently choose to remain undetected for extended periods. This shows that this attack is often expensive and difficult to carry out.

2) *Cyber Terrorism*: Cyber terrorism is the general term for any organized, politically motivated attack on information systems, programs, and data that makes violent threats or results in violent acts. The term is occasionally expanded to refer to any cyberattack that intimidates or inspires fear among the target population. Attackers commonly achieve this by damaging or degrading crucial infrastructure. The purposeful use of computers, networks, and the public internet to cause harm and achieve one's objectives is known as cyberterrorism. A nation may be forced to flee due to the catastrophic damage that talented and experienced hackers may do to government systems. The objectives of such terrorists may be political or ideological because this is a form of terrorism.

3) *Cyber Warfare*: A cyberattack or group of attacks that target a nation are typically referred to as cyberwarfare. The nation's critical infrastructure could be disrupted or hurt by this kind of attack. A nation-state often engages in cyberwarfare by attacking another nation-state. Attacks may, however, occasionally be carried out by terrorist groups or other non-state actors who support the objectives

of an adversarial country. There have been many reported instances of cyber warfare in recent years, but there is no clear, agreed-upon definition of when a cyber-attack qualifies as an act of war.

4) *Cyber Fraud*: Any fraudulent behavior that uses the internet or other digital communication technology is called "cyber fraud." This can encompass a variety of illegal actions, including hacking, identity theft, credit card fraud, and phishing scams.

5) *Cyber Bullying / Harassment*: Cyberbullying, sometimes referred to as online bullying, is a type of abuse that occurs across digital platforms like social media, email, text messaging, and other websites. It entails harassing, threatening, or intimidating someone through electronic correspondence. Sending threatening or abusive messages, spreading false information about someone online, sharing private or intimate photos without permission, creating fictitious social media profiles to harass someone, and posting hateful comments on social media and other online platforms are examples of cyber harassment.

6) *Cyber Theft*: Cybercrime is the theft of digital data, cash, or other assets from computer networks or the internet. Hackers and other cybercriminals frequently commit this kind of crime using various techniques, such as phishing, malware, and social engineering, to access confidential data or financial resources.

## B. Defining Law Enforcement

The people and organizations tasked with upholding the law and preserving the peace are known as law enforcement. This includes institutions like the police, CBI, NIA, and other governmental bodies entrusted with upholding rules and laws about public safety and crime. Law enforcement's responsibilities include keeping public security, preventing crime from occurring, and ensuring that those who break the law are held accountable. They might perform various duties, including acquiring evidence, investigating crimes, detaining suspects, and bringing cases against offenders. Law enforcement authorities are crucial to investigating and prosecuting cybercriminals in the context of cybercrime. They work to locate and identify those responsible for cybercrime so that they can be prosecuted.

## II. LITERATURE REVIEW

Cybercrime is an issue that needs a precise definition, which makes it difficult for individuals and organizations to respond effectively [3]. Also, victims of cybercrime often do not report the crime to the police because people feel that law enforcement personnel may not have the necessary training to handle such cases [4]. The pandemic has exacerbated this problem, as people use the internet more frequently for work, school, and entertainment, making them more susceptible to cybercrime [5]. Changes in people's behavior, with more activities moving online, have also led to an increase in cybercrime worldwide, a problem that researchers and police still struggle to understand [4].

Overall, the pandemic has highlighted the need for more research and training to address the growing problem of cybercrime and to help individuals and organizations protect themselves from cyber threats [6]. Law enforcement personnel can better investigate and catch cybercriminals by developing a more comprehensive system for understanding cybercrime and educating the public about protecting themselves [3, 4]. Psychiatrists should also be well informed about the potential effects of cybercrime and educate their patients about cybersecurity [5].

Cybercrime is proliferating in Africa, and many attacks from the continent are targeted at other parts of the world. However, steps are being taken to combat this problem [7]. Mostly property crime is now online, with traditional fraud and scams costing the average citizen a few hundred pounds/dollars per year. The costs of securing computer systems against cybercrime are in the tens of dollars annually [8]. New policing strategies are being used to combat cybercrime markets, such as "infrastructural policing" and "influence policing," which target the administrators [9]. People need to be more aware of cybersecurity, and policymakers should promote this issue and increase regulation. In the future, the research could compare the effectiveness of different methods of preventing cybercrime and the factors affecting African economies' legal and regulatory frameworks [7]. Globalization has made the world borderless, and countries compete in various fields. However, this has also led to an increase in cybercrime that crosses the jurisdictional limits of a country [10].

The Budapest Convention is being used as a model for creating cybercrime laws in many countries, including some Pacific Island Countries (PICs) [11]. The report recommends spending more on responding to cybercrime rather than trying to prevent it in advance and improving law-enforcement action against cybercriminals [8]. The law, globalization, and politics counter cybercrime by applying legal norms between nations. Cybercrime regulation in legislation is essential, and foreign policies between nations play a significant role in regulating all forms of advances in information technology, communication, and transportation [10]. While implementing cybercrime laws in PICs is essential, many need more resources and expertise to enforce them effectively. Despite this, many PICs are still interested in joining the convention for reforming their cybercrime laws [11]. The article suggests that better victimization studies are needed to measure the impact of cybercrime and that cybercrime is an increasingly important issue that needs to be taken seriously [8]. While many PICs may have comprehensive cybercrime legislation in the future, their implementation will likely face various challenges [11].

Measures such as reducing political leaders' flamboyant lifestyles, increasing workers' salaries, and creating job opportunities can help to discourage criminal tendencies. Overall, the paper suggests introducing social, economic, and political measures to address this cause of cybercrime in Africa. [12] The study recommends more user-centric workflows and tools and provides a foundation for future

research in the field. However, the study has limitations, such as limited sample size and variations in information gathered from each participant.[13].

Globalization has made regulations on investment, trade, services, and information technology in developing countries similar to those of developed countries. Cyberspace activities cannot be separated from relationships with other countries, and the norms of law between nations play an important role in regulating information technology, communication, and transportation [14]. To regulate cybercrime, there is a need for cyber law that includes jurisdiction outside the state territory. Globalization demands policy changes to allow capital, technology, and labor to move quickly between countries [14].

Technology has developed rapidly in Indonesia, and this has had an impact on society and security. The internet has created new threats, such as cyber-based crimes, which can harm people. Children are particularly vulnerable to cybercrime, and it is important to follow regulations for using social media and for parents to supervise their children's internet use to avoid criminal sanctions or compensation [15]. While cybersecurity is essential to protect our data and networks from unauthorized access, humans remain the biggest concern for cybersecurity as they can be easily tricked into revealing information [16]. While the future of cybersecurity is uncertain, it is believed that people and technology can work together to find solutions to mitigate these threats [16].

As artificial intelligence (AI) continues to develop, cybercrime using AI is becoming a threat to national security, public safety, and personal privacy [17]. Indonesia's legal system and law enforcement agencies must be adequately equipped to handle cybercrime [18]. Cybercrime is also increasing in India, and it is difficult to trace the criminals [19].

Even metaverse, another cutting-edge tech, has not been spared by cyber criminals. Financial cybercrime in the metaverse has increased in recent years, with stealing cryptocurrencies from exchanges or selling fake financial products becoming more common. [20] Since these activities occur in a virtual world, there are few regulations, and crimes are only sometimes prosecuted. Cybercrime is a big problem in the US but it is difficult to measure and combat. [21] There are three main challenges in trying to police cybercrime: needing more knowledge, forensic tools, and legal challenges. [22] The paper interviewed cybercrime experts from eight countries to learn more about these challenges. The authors of a different paper want to raise awareness about the gaps in Nigeria's ability to deal with cybercrime. [23] There is a law about cybercrime, but it is not enough. The paper suggests ways to fix this problem, like educating people in the justice system about technology. It discusses how crime changes in the digital age and how formal investigation and crime prevention methods are becoming obsolete. [24] Investigating individual crimes is no longer enough to combat the rise of cybercrime and other forms of mass delinquency. Instead, a more holistic approach called criminal intelligence is needed to anticipate and prevent these crimes. Islamic finance could

solve this problem by connecting financial services and instruments to real and virtual assets without speculation. [20] New regulatory and compliance frameworks and cybersecurity mechanisms are needed to prevent these crimes. [20] Law enforcement officers and people in the justice system must learn to handle cybercrime cases. [23] The paper recommends improving training for police officers and using a standard definition of cybercrime. [22] Law enforcement agencies must work with private sector cybersecurity experts to develop effective strategies to combat cybercrime. [24].

There needs to be an increase in trained law enforcement personnel and improvements in the facilities and resources available in Indonesia [18]. Awareness programs and workshops must be conducted to prevent or avoid cybercrime in India [19]. With the increasing use of technology, cyber laws must be updated to keep up with new developments [25].

Women, children, and senior citizens are the most affected by cybercrime in India [19]. Overall, there are areas for improvement in the current enforcement of cybercrime laws in Indonesia, and improvements are necessary to combat this growing problem effectively [18]. Cyber laws apply to all people using technology, making it essential for lawmakers, internet providers, banks, shopping websites, and others to work together to prevent cybercrime [25]. To minimize cybercrime, secure technology, and networking systems must be designed and implemented, and awareness workshops must be conducted [19]. The increasing prevalence of cybercrime is a concern for smart cities in India, and a study by [26] aims to identify the various aspects and factors that in turn would influence citizens to prevent cybercrimes.

### III. RESULT AND DISCUSSION

This paper discussed various aspects of cybercrime and its impact on society. After the pandemic, people use the internet more for school, work, shopping, entertainment and many more things. Therefore, law enforcement in every country needs to develop a more comprehensive system for understanding cybercrime and educating people to protect themselves [28]. There is a need for strong cyber laws in every country that includes jurisdiction outside the state territory to regulate cybercrime. Here we also show the Internet users worldwide in the tables below:

TABLE I. WORLD INTERNET USERS AND POPULATION

World Regions	Population (2022 Est.)	Population % of World	Internet Users (31 Dec 2021)
Africa	1,394,588,547	17.6%	601,940,784
Asia	4,352,169,960	54.9%	2,916,890,209
Europe	837,472,045	10.6%	747,214,734
LATAM / Carib.	664,099,841	8.4%	534,526,057
North America	372,555,585	4.7%	347,916,694
Middle East	268,302,801	3.4%	206,760,743
Oceania / Aus.	43,602,955	0.5%	30,549,185

World Regions	Population (2022 Est.)	Population % of World	Internet Users (31 Dec 2021)
World Total	7,932,791,734	100%	5,385,798,406

Source: World Internet Users statistics and 2023 World Population stats [27]

TABLE II. WORLD INTERNET GROWTH RATE

World Regions	Penetration Rate (% Pop.)	Growth 2000-2023	Internet World %
Africa	43.2%	13,233%	11.2%
Asia	67%	2,452%	54.2%
Europe	89.2%	611 %	13.9%
LATAM / Carib.	80.5%	2,858%	9.9%
North America	93.4%	222%	6.5%
Middle East	77.1%	6,194%	3.8%
Oceania / Aus.	70.1%	301%	0.6%
World Total	67.9%	1,392%	100%

Source: World Internet Users statistics and 2023 World Population stats [27]

A research paper analysis method was used in this study, where we collected the data from secondary and tertiary legal archives [1,27]. We study and examine the situation raised by excessive internet use by many people worldwide. According to the analysis, by 2023, the yearly cost of cybercrime will be \$8 trillion, representing the largest transfer of wealth in recorded history. In upcoming years, it will increase by 15% in cybercrime cost, reaching \$10.5 trillion by 2025 [29]. An average of 8,00,000 hacker assaults occur annually, with over 2328 daily, or one every 39 seconds. Thirty-three billion account breaches are predicted to occur by 2023 [29].

We know that the growing threat of cybercrime is a severe issue. Many developing and underdeveloped nations face cyber attacks by other nations or organizations. Therefore, the Budapest Convention on Cybercrime is used as a model for cybercrime legislation in many countries, including some Pacific Island Countries (PICs) [11]. The convention promotes international cooperation in investigating cybercrime between nations and encourages the development of international laws against cyber criminals, which helps improve cyberspaces. Most of the member states of the European Union and the United States, Canada, Japan, and South Africa are among the 65 nations that have accepted the Budapest Convention as of April 2023.

The world is now more connected digitally than ever before. So, Criminals target vulnerabilities in online systems, networks, and infrastructure by taking advantage of this online transition. Governments, companies, and people worldwide are heavily impacted economically and socially. Data breaches, ransomware, and phishing are only a few modern cyber threats, and new varieties of cybercrime are constantly emerging. Cybercriminals are becoming more coordinated and nimble, using new technology, customising attacks, and forming novel partnerships. In order to lessen cyber threats, INTERPOL coordinates law enforcement operations and provides secure data-sharing platforms, analysis, and training [30]. They can contribute to protecting communities for a safer world by enhancing the ability of

their member nations to stop, identify, investigate, and disrupt cybercrimes. Thus, close cooperation between public and commercial partners is crucial. INTERPOL's global presence is crucial in encouraging cross-sector collaboration and facilitating cross-border law enforcement cooperation [30].

#### IV. CONCLUSION

In conclusion, analyzing the distinct approaches implemented worldwide shows a huge need for preventive cybersecurity measures. Prioritizing cybersecurity and criminal law studies in the AI era is crucial to ensure the stable implementation of cybersecurity measures. As technology and globalization continue to advance, being aware and knowledgeable about the most recent scamming techniques is crucial for protecting ourselves from cybercrime. With the increasing use of technology, cyber laws must be regularly updated to make it easy to keep up with new developments. The paper pierces the veil need for more research and training in order to address the growing issue of cybercrime and protect individuals and organizations from upcoming cyber threats. By working together, combating cybercrime for public safety and personal privacy is possible.

#### REFERENCES

- [1] "Digital around the world," DataReportal – Global Digital Insights. [Online]. Available: <https://datareportal.com/global-digital-overview>. [Accessed: 04-Apr-2023].
- [2] F. T. Ngo and K. Jaishankar, "Commemorating a decade in existence of the international journal of cyber criminology: a research agenda to advance the scholarship on cyber crime," *International Journal of Cyber Criminology*, vol. 11, no. 1, 2017.
- [3] K. Phillips, J. C. Davidson, R. R. Farr, C. Burkhardt, S. Caneppele, and M. P. Aiken, "Conceptualizing cybercrime: Definitions, typologies and taxonomies," *Forensic Sciences*, vol. 2, no. 2, pp. 379–398, 2022.
- [4] J. Curtis and G. Oxburgh, "Understanding cybercrime in 'real world' policing and law enforcement," *The Police Journal*, pp. 0032258X – 221107584, 2022.
- [5] S. Monteith, M. Bauer, M. Alda, J. Geddes, P. C. Whybrow, and T. Glenn, "Increasing cybercrime since the pandemic: Concerns for psychiatry," *Curr. Psychiatry Rep.*, vol. 23, no. 4, p. 18, 2021.
- [6] D. Buil-Gil, F. Miró-Llinares, A. Moneva, S. Kemp, and N. Díaz-Castaño, "Cybercrime and shifts in opportunities during COVID-19: a preliminary analysis in the UK," *Eur. Soc.*, vol. 23, no. sup1, pp. S47–S59, 2021.
- [7] N. Kshetri, "Cybercrime and cybersecurity in Africa," *J. Glob. Inf. Technol. Manag.*, vol. 22, no. 2, pp. 77–81, 2019.
- [8] R. Anderson, C. Barton, R. Böhme, R. Clayton, C. Ganán, T. Grasso, ... & M. Vasek, "Measuring the changing cost of cybercrime," 2019.
- [9] B. Collier, D. R. Thomas, R. Clayton, A. Hutchings, & Y. T. Chua, "Influence, infrastructure, and recentering cybercrime policing: evaluating emerging approaches to online law enforcement through a market for cybercrime services," *Policing and Society*, vol. 32(1), 103–124, 2022.
- [10] G. T. P. Siregar and S. Sinaga, "The law globalization in cybercrime prevention," *Int. J. Law Reconstr.*, vol. 5, no. 2, p. 211, 2021.
- [11] L. Nguyen and C. Golman, "Diffusion of the Budapest Convention on cybercrime and the development of cybercrime legislation in Pacific Island countries: 'Law on the books' vs 'law in action,'" *Computer law & security Review*, vol. 40, 2021.
- [12] N. U. Richards and F. E. Eboibi, "African governments and the influence of corruption on the proliferation of cybercrime in Africa: wherein lies the rule of law?," *Int. Rev. Law Comput. Technol.*, vol. 35, no. 2, pp. 131–161, 2021.

- [13] M. Nouh, J. R. C. Nurse, H. Webb, and M. Goldsmith, "Cybercrime investigators are users too! Understanding the Socio-technical challenges faced by law enforcement," arXiv [cs.HC], 2019.
- [14] A. Jeronimo, "The globalization effect of law and economic on cybercrime," *J. Pembaharuan Huk.*, vol. 6, no. 3, 2019.
- [15] I. Musofiana, A. Sudarmaji, and I. A. Maerani, "Aspects of legal protection for children from cybercrime," *J. Pembaharuan Huk.*, vol. 7, no. 3, p. 201, 2020.
- [16] M. Sharma and S. Kaur, "Cyber crimes becoming threat to cyber security," *Academic Journal of Forensic Sciences ISSN*, 2019.
- [17] X. Wang, "Criminal law protection of cybersecurity considering AI-based cybercrime," *J. Phys. Conf. Ser.*, vol. 1533, no. 3, p. 032014, 2020.
- [18] B. T. Bawono, "Reformation of law enforcement of cyber crime in Indonesia," *J. Pembaharuan Huk.*, vol. 6, no. 3, 2019.
- [19] P. Datta, S. N. Panda, S. Tanwar, and R. K. Kaushal, "A technical review report on cyber crimes in India," in *2020 International Conference on Emerging Smart Computing and Informatics (ESCI)*, 2020.
- [20] K. Katterbauer, H. Syed, and L. Cleenewerck, "Financial cybercrime in the Islamic finance metaverse," *JMV*, vol. 2, no. 2, pp. 56–61, 2022.
- [21] M. Brunner, "Challenges and opportunities in state and local cybercrime enforcement," *J. Nat'l Sec. L. & Pol'y*, vol. 10, 563, 2019.
- [22] S. De Paoli et al., "A qualitative exploratory study of the knowledge, forensic, and legal challenges from the perspective of police cybercrime specialists," *Polic. J. Policy Pract.*, vol. 15, no. 2, pp. 1429–1445, 2021.
- [23] K. H. Mohammed, Y. D. Mohammed, and A. A. Solanke, "Cybercrime and digital forensics: Bridging the gap in legislation, investigation and prosecution of cybercrime in Nigeria," *The International Journal of Cybersecurity Intelligence and Cybercrime*, vol. 2, no. 1, pp. 56–63, 2019.
- [24] B. Jerome, "Criminal investigation and criminal intelligence: Example of adaptation in the prevention and repression of cybercrime," *Risks*, vol. 8, no. 3, p. 99, 2020.
- [25] S. Kaikini, K. Agarwal, K. Raj, and S. Kulshrestha, "Statics on Cyber Crimes and Cyber Laws in India: A Study," *JOURNAL OF ALGEBRAIC STATISTICS*, vol. 13, pp. 2935–2944, 2022.
- [26] S. Chatterjee, A. K. Kar, Y. K. Dwivedi, and H. Kizgin, "Prevention of cybercrimes in smart cities of India: from a citizen's perspective," *Inf. Technol. People*, vol. 32, no. 5, pp. 1153–1183, 2019.
- [27] "World Internet Users statistics and 2023 world Population stats," *Internetworldstats.com*. [Online]. Available: <https://www.internetworldstats.com/stats.htm>. [Accessed: 04-Apr-2023].
- [28] "Internet Crime Complaint Center(IC3)," *Ic3.gov*. [Online]. Available: <https://www.ic3.gov/>. [Accessed: 05-Apr-2023].
- [29] N. James, "90+ cyber crime statistics 2023: Cost, industries & trends," *Astra Security Blog*, 21-Oct-2021.
- [30] M.-C. Frunza, "Cybercrime," in *Introduction to the Theories and Varieties of Modern Crime in Financial Markets*, Elsevier, 2016, pp. 207–220.

# Social Engineering Attack - Scopes, types and its working

1<sup>st</sup> Tanisha Dixit  
MCA 1<sup>st</sup> Year Student  
Institute of Technology & Science  
Mohan Nagar, Ghaziabad, India  
tanishadixit\_mca22\_24@its.edu.in

2<sup>nd</sup> Prajjwal Pandey  
MCA 1<sup>st</sup> Year Student  
Institute of Technology & Science  
Mohan Nagar, Ghaziabad, India  
prajjwalpandey\_mca22\_24@its.edu.in

3<sup>rd</sup> Puja Dhar  
Assistant Professor  
Institute of Technology & Science  
Mohan Nagar, Ghaziabad, India  
coord.mca@its.edu.in

**Abstract**—The digital world is expanding and evolving rapidly, everything is online now luring attackers to obtain sensitive information illegally. So, it's being an urgency to make our computer systems safer. Some technologies have come into the picture for better security like firewalls, antivirus software, cryptography methods, etc. but still hackers can get your data. One of the weaker points of the cyber security chain is human nature because of its greediness, urgency, and trust issues. Social engineering is the attack on weakness that is openly exploiting humans. This type of attack is successful at a high rate and has the rarest chance to leave any trace behind. Here is the necessity to detect and mitigate such attacks. This research paper will provide you with a deep awareness of social engineering, its work, and precautionary methods to save your data from attackers.

**Keywords**—Social Engineering, Cyber Security, Phishing, Physical Breaching, Pretext Calling, Piggybacking, Dumpster Diving, and Multi-Factor Authentication.

## I. INTRODUCTION

Social Engineering is not what its name suggested. It's the biggest threat of this technical world that can cost more than a natural disaster.

Despite the latest technologies and security measures being deployed and promoted, the bar representing the number of security breaches is rising consistently [4]. The main reason being suspected behind this can be a cybercriminal's tendency to target a weak and vulnerable access point. One can surely say that no security issue can arise unless there is any vulnerability that can be exploited by cybercriminals [4]. Security Breaches can cause high-magnitude damage to organizations in the form of customer distrust [9] and decreased stock prices[10]. According to the 2022 cost of data breach report by IBM and Ponemon Institute, the average cost of a data breach has reached a record high of US \$4.35 million [11]. Social Network today has become the most popular

medium and attract millions of people worldwide to express their photos, location, and a lot more information with others. This increased popularity has attracted cybercriminals to use social networks to gather information and use these platforms as a rich setting to target any individual or any organization. For Instance, social networks have been used in lots of cyber-bullying cases[12]. With the use of social media, social engineers can launch direct attacks such as phishing [13] and reverse social engineering [12], or indirect attacks when the target's social handles are hacked to collect data and launch attacks in other contexts. For example, tracking a group of employees of Company X through multiple social network channels to launch social engineering attacks against that company. Most people rely on social network providers to protect their privacy and security from cybercriminals and this is a common tendency among the users of social networking sites.

Social engineers with malicious intentions use strategies that are deceptive to accept bait instead of using conventional technical ways to convince their targets to give their sensitive information.

Using sophisticated and advanced methods to manipulate the user or the machine (with vulnerabilities) to access sensitive information is known as Social Engineering. There are a lot of cases in which communication media such as emails, telephone, and the latest social networks have been affected by social engineering attacks.

## II. TYPES OF SOCIAL ENGINEERING

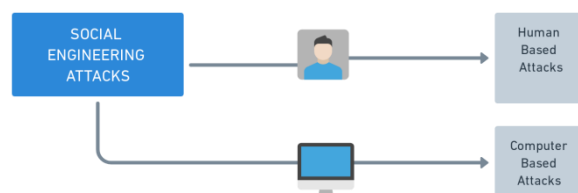

Fig 1: Types of Social Engineering

### A) Human-Based Social Engineering

Carrying out human-based attacks involves a lot of planning as the attacker needs to plan out environmental aspects in the context of the target and technical aspects related to the target's system. In most cases, it is seen that attackers try to look legitimate and someone related to the organization in any way like technical support or IT help desk guy to trick or bait the target to perform actions that can provide a way for the attacker to proceed further. Some of the common methods of human-based attacks are –

- *Eavesdropping*: Includes interception of any type such as communication, audio, videos, or written.
- *Shoulder Surfing*: This involves looking into someone's device, especially at the time the target enters some kind of credentials with the motive to steal identity or info.
- *Tailgating*: This technique involves an unauthorized person closely following a certified person into a secured area.
- *Piggybacking*: This technique involves an unauthorized person convincing a certified person to permit him/her into a secured area.[21]

### B. Computer-Based Social Engineering

This type of social engineer attack completely depends on packages or updates that are sent to retrieve data or execute malicious code. No direct human interaction is required. Some common methods of computer-based attacks are -

- *Popup Window*: In this type of attack target gets a popup to get something free or update network settings by putting in their email/username and password which is then logged and sent to the attacker at some remote location.
- *Attachments*: Many email/message attachments are not just the type of attachment they pretend to be, they are binary executables that are coded to execute malicious code once clicked and opened.
- *Websites*: There are lots of malicious websites that collect data from different people that visit them and sell to companies at very high rates to gain profit.[21]

## III. HOW DOES SOCIAL ENGINEERING WORK?

Any Social engineering when carried out involves 4 phases.

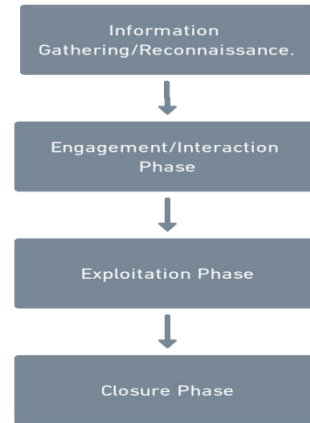

Fig 2: Model (Four phases on which a Social Engineer works)

### A. 1st Phase—Reconnaissance or Information gathering.

The first phase of any social engineering attack consists of a selection of the target, and the collection of the necessary information about the target, at this stage every minute detail is important. Further stages depend on this stage as the probability of a social engineering attack being successful is directly proportional to the amount of data collected about the target at this stage.

A good social engineer keeps his/her aim in mind to collect required information effectively. Collection and analysis of irrelevant information can cause disruptions in the successful completion of social engineering attacks.

Broadly there are 3 ways of reconnaissance or information gathering

#### 1) Technical or Online Sources

Technical sources include every way in which information can be accessed through technical means for example posts, blogs, social media handles, phone calls, searches, etc.

These technical aspects cover OSINT or OPEN-SOURCE INTELLIGENCE which includes any knowledge that can be gathered through online platforms, search results, and other sources about the target.

OSINT is divided into 6 different categories: -

- *Media*—This includes the information about the target which we get through their photos, videos, audio files, clips, etc.
- *Internet*—This information about the target is gathered from their social media handles, searches, emails, posts, app usage data, etc.
- *Public Government Data*—This kind of information about the target is gathered through public databases such as information of any particular target if obtained from Aadhar DB in India.
- *Professional and Academic publications*—This kind of information about the target refers to information derived from school or college or any examination portal.

- *Commercial Data*—This kind of information refers to the data collected from the business of the target or from the company's handle for which the target provides service or had worked in the past.
- *Grey Literature*—This sort of information is collected from any kind of literature which has no link to the target in the present situation but points to some important history of the target which can be used further for gathering more information.

#### 2) *Physical Reconnaissance*

Physical reconnaissance is a part of human-based social engineering in which information is gathered by being physically present around the target.

Some points to be kept in mind during this process involve the: -

- Outfit of the target.
- Normal Working Hours.
- Third-party services used by the target.
- Access points to reach the target and security measures taken for protection.

If physical reconnaissance is being carried out as a part of any social engineering attack, then a pre-evaluation of security measures and all the physical security aspects such as cameras, doors, and guards need to be taken care of to make the attack successful. Suspicion of any of the physical security staff may lead to failure of attacks in such cases.

#### 3) *Dumpster Diving*

Dumpster Diving is a method of collecting information about the target from the trash or traces of information in the organization for which the target is currently working or has worked. Dumpster diving is a very effective way of finding information especially if the target is the type of person having fewer digital footprints as a consequence of being a less active user of the internet or social media platforms or a person with old age and less understanding of technical aspects of the Internet and computers.

#### B. 2nd Phase—*Engagement or Interaction phase*

In this phase, a social engineer tries to interact with the target to build trust or with the intent of stealing crucial information that can help in further stages of the attack. In this phase, every piece of information collected during the first phase is linked up to connect the dots and bait the target to make some kind of mistake that can pave the way for further execution of the attack. There are several methods of engagement developed with some having capabilities of remote execution.

##### 1) *Phishing*

This method of engagement comes under human-based attacks as it requires the target to click on some sort of links that appear to come from a legitimate and trustworthy source.

##### 2) *Spear Phishing*

This method, like phishing, lies in the category of human-based attacks. At the same time unlikely to phish in this method, a targeted Email or SMS is sent to a particular person having administrator rights to get access to the systems, infect the systems, create a backdoor or retrieve credentials or data.

##### 3) *Vishing*

Vishing is often called Voice phishing. This type of phishing attack interacts with the target directly over a phone call and the target is then tricked to trust that the caller is from a legitimate government institution or bank and is asked about his credentials at last information is compromised if the target is not knowledgeable enough to handle this.

##### 4) *Impersonation or Pretext Calling*

During this attack information collected in 1st phase is used to connect the dots and is used to trick the target into something related to his/her life with a proper pretext which is planned to get particular detail to steal information or money. Expectations are to trick the target into something that is happening in the life of the particular person and make him/her believe that the caller is from a genuine source.

#### C. 3rd Phase—*Exploitation Phase*

After a successful end to the 1st and the 2nd phase of the attack comes the most important part of the whole attack,

Till this phase begins it is assumed that the social engineer has enough details and credentials to hack into the target systems with the intent of stealing money, identity, or data. An important point to keep in mind is avoiding any sort of clash or conflict between social engineering teams regarding the goal to be achieved.

Some scenarios that can be formed in this step could be: -

- Direct stealing of money/data/identity and closing the attack
- Using the hacked system to hack into other systems to get access to the whole network. This is called Pivoting. This is a way of gaining access to a device that is restricted to a particular subnet and has no access outside it indirectly by hacking into some other system connected to it.
- Executing system commands on a hacked machine and trying to get admin access.
- Generation of backdoor and leaving it for future use.

There are various hacking tools available for different post-exploitation attacks such as Meterpreter which is used to execute the system commands on hacked computers with the help of its command line interface.

#### D. 4th Phase—*Closure*

This is the last and final phase of any social engineering attack. This phase is very crucial from a social engineer's point of view as in this phase all the shreds of evidence such as any logs of networks or hard disks or malware access to the

target system need to be cleared as nowadays with the help of cyber forensics the logs stored in the system at various locations can help identify the attacker could lead to imprisonment.

#### IV. COMMON FORMS OF SOCIAL ENGINEERING ATTACKS

*A. Phishing*—A most organized threat of the 21st century as it cannot be tracked down because of its malicious nature[7]. Phishing is an email-based social engineering attack where cyberpunks camouflage emails or SMS to appear as admissible solicitors for personal and sensitive information. Such emails usually contain messages from a trustworthy-looking source that convinces users to click a link attached to those emails where they are asked to enter passwords or other sensitive or credential details to get access to it [2].

In march 2022, Mailchimp’s employees were being the victims of social engineering. They were tricked by the attackers to cough up their credentials. Those credentials were used to access the Mailchimp customer accounts unauthorized manner. After gaining access to 319 MailChimp customers' accounts, they delivered mailing lists to 102 accounts. Attackers used those accounts to dispatch phishing attacks, which appeared to be authorized because they were launched from MailChimp emails. Attackers could have infiltrated the application programming interface key that may be used to deliver more email-based phishing campaigns automatically.

Trezor, a cryptocurrency wallet company, spotted first that the data of MailChimp had been breached and attackers were getting access to data to launch their phishing campaign against its clients. Trezor’s customers received emails containing malicious code to trick them into downloading that code and entering their sensitive pieces of information to access their Trezor wallets. But the detection of those phishing campaigns could help to diminish the downstream effects of supply chain attacks on MailChimp [6].

In 2022, Russia has actively pursued phishing against Ukraine as part of its ongoing campaign of aggression against the country. These attacks spread malware, disrupted power supplies, and stole data. In retaliation, Ukraine has started implementing its own virus, leading to significant data breaches.

In most cases, phishing emails clear users’ accounts or send emails to the clients of a particular company after getting confidential information from that company to get more financial benefits.

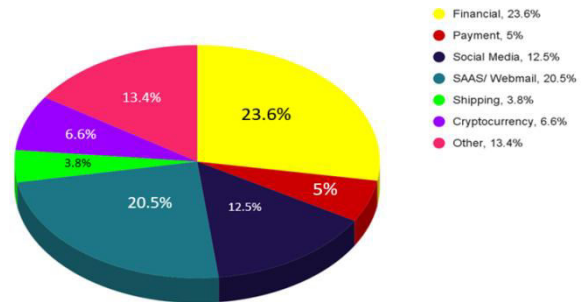

FIG III.A: Most-Targeted Industries, 2022[4]

This pie chart elaborates on phishing scams. At least 50% of the phishing scams have been conducted over financial firms, payments, or SaaS/webmail [4]. As constant growth of the number of online banking users and online services is being an allurement for the attackers to commit phishing [6].

*B. Physical Breaching*—In this kind of social engineering attack, the social engineering attack is conducted by physical approaches. Sensitive documents and computer files can be vulnerable to theft or accidental exposure if not kept physically secured.[16]. Hackers are stealthy assassins who can slip inside buildings and blend with the employees[17]. They perform an often-used technique, called dumpster diving[16]. They dive into dumpsters in search of valuable information like passwords, filenames, or other pieces of confidential information that can be used to compromise a computer system or any particular user account [17]. For instance, a company’s computers are left unattended and left on. It has been accessed by an unauthorized person who has gained access to them by searching for and taking files on the computer or reading its email.

*C. Pretext Calling*— In a pretexting attack, the hacker tries to create a fictitious scenario to steal the victim's sensitive information [15]. It is based on random phone calls that let their prey believe in attackers.

For instance, an attacker fetches data about the network and system of targeted organization X by contacting an employee to solve the technical issues in their system and network. That employee believes and gives the information to attackers. This information may be a wi-fi password, username, or any security question. That helps attackers to hack into the system. The pretext may be the recommendation to serve a service or to get employment, asking about confidential data, helping a friend to get access to something, or winning a lottery [1]. Such attacks are triumphant and untraceable in 70% of the cases [15].

#### IV. PRECAUTIONS

Social engineers spot and try to exploit the weakest connector, that is, humans. Such a threat is the least costly to

the attackers [14]. This is why precaution is preeminent that will lead us to secure from future social engineer attacks.

*A. Multi-Factor Authentication*—Never rely on one factor, that is, a password. Passwords ensure security but social engineers can crack them. They are inadequate on their own. So, multi-factor verification is mandatory which could be like biometric access or any security question [18].

*B. Confirm The Email's Source Identity*—Mostly, scams have been done because of developing trust identity. Especially in phishing attacks, attackers send mail that resembles a trusted organization to make you click on that false link. To evade this kind of social engineering threat, contact the claimed organizations and confirm whether it is sent by them or not[19][1].

*C. Pay Attention To Digital Footmarks*—Oversharing personal information online through social media can make the attacker know more about you [16]. For instance, if you upload your curriculum vitae online. All the useful information like your date of birth, phone number, and

residential address could be used by the attackers to plan a social engineering attack.

Maintain your social media settings to 'friends only' and think before you share something on social media.

#### *D. Good Spam Filters*

If the email program is not able to filter out spam or suspicious mail, you might change the settings. A good spam filter determines which emails are likely to be spam. It detects suspicious links and keeps them on the blacklist of suspicious IP addresses [20].

## V. CONCLUSION

In this research paper, we have sketched social engineering attacks, their work, and precautions to not be affected by such attacks. Social engineering attacks are being done at a high intensity as it is an inexpensive way to retrieve sensitive information without letting anybody know about it. That's the major reason the rate of such attacks is increasing rapidly. This paper is also for awareness-raising about the danger of such attacks to neutralize the harsh damage done by attackers.

## REFERENCES

- [1] Segovia, L.; Torres, F.; Rosillo, M.; Tapia, E.; Albarado, F.; Saltos, D. Social engineering as an attack vector for ransomware. In Proceedings of the Conference on Electrical Engineering and Information Communication Technology Pucon, Chile, 18–20 October 2017; pp. 1–6. [Google Scholar] [CrossRef]
- [2] Ponemon Institute and IBM Security (2017) 2017 cost of data breach study: a global overview URL - <http://universe.byu.edu/wp-content/uploads/2017/10/Ponemon-2017-Study.pdf>
- [3] Mulligan DK, Schneider FB (2011.) Doctrine for cybersecurity.
- [4] Reported Phishing Attacks Reach an All-Time High, Luke Irwin, 7th July 2022, URL - <https://www.itgovernance.eu/blog/en/reported-phishing-attacks-reach-an-all-time-high>
- [5] The Biggest Phishing Breaches of 2022 and How to Avoid them for 2023 by Ryan McCurdy on November 8, 2022, URL- <https://securityboulevard.com/2022/11/the-biggest-phishing-breaches-of-2022-and-how-to-avoid-them-for-2023>
- [6] Laerte Peotta, Marcelo D. Holtz, Bernardo M. David, Flavio G. Deus, Rafael Timóteo de Sousa Jr., a formal classification of internet banking attacks and vulnerabilities in International Journal of Computer Science & Information Technology (IJCSIT), Vol 3, No 1, Feb 2011
- [7] Ike Vayansky, Sathish Kumar, Coastal Carolina University, Phishing – challenges and solutions in Computer Fraud & Security Volume 2018, Issue 1, January 2018, Pages 15-20
- [8] Borah A, Martin KD, Palmatier RW (2017) Data Privacy: effects on customer and firm performance.
- [9] Hinz O, Nofer M, Schiereck D, Trillig J (2015) The influence of data theft on the share prices and systematic risk of consumer electronics companies.
- [10] Cost of a data breach 2022, A million-dollar race to detect and respond. URL - <https://www.ibm.com/reports/data-breach>
- [11] Singh MM, Ng PJ, Yap KM, Husin MH, Malim NHANH (2017) Cyberbullying and a mobile game app? An initial perspective on an alternative solution. (559 - 572)
- [12] Vishwanath A (2015) Habitual Facebook use and its impact on getting deceived on social media (83 - 98).
- [13] Irani D, Balduzzi M, Balzarotti D, Kirda E and Pu C (2011) Reverse social engineering attacks in online social networks. In: International conference on detection of intrusions and malware, and vulnerability assessment (55 - 74)
- [14] Nabie C, Paul S. Cybersecurity: risks, vulnerabilities and counter measures to prevent social engineering attacks. Int J Adv ComputRes.2016;6:31–8. <https://doi.org/10.19101/IJACR.2016.623006>.
- [15] Salahdine F, Kaabouch N. Social engineering attacks: a survey. Future Internet, 11(4), 2019. ISSN 1999-5903. <https://doi.org/10.3390/fi11040089>. URL <https://www.mdpi.com/1999-5903/11/4/89>. Accessed 24 Oct 2020
- [16] Arif KOYUN, Ehssan Al Janabi. Social Engineering Attacks, Journal of Multidisciplinary Engineering Science and Technology (JMEST) ISSN: 2458-9403 Vol. 4 Issue 6, June - 2017, URL: <https://www.jmest.org/wp-content/uploads/JMESTN42352270.pdf>
- [17] Scott Pinzon, Jack Wiles, and Kevin C. Mitnick, "No Tech Hacking: A Guide to Social Engineering, Dumpster Diving, and Shoulder Surfing", Syngess Publishing, Inc. Elsevier, Inc. ISBN 13: 978-1-59749-215-7 [https://books.google.co.in/books?hl=en&lr=&id=Fe63fUkm2oMC&oi=fnd&pg=PP1&dq=dumpster+diving+social+engineering&ots=sysoCjx2eA&sig=qsoAJ6lcc9X5oRRe9yjdmaOlrIM&redir\\_esc=y#v=onepage&q=dumpster%20diving%20social%20engineering&f=false](https://books.google.co.in/books?hl=en&lr=&id=Fe63fUkm2oMC&oi=fnd&pg=PP1&dq=dumpster+diving+social+engineering&ots=sysoCjx2eA&sig=qsoAJ6lcc9X5oRRe9yjdmaOlrIM&redir_esc=y#v=onepage&q=dumpster%20diving%20social%20engineering&f=false)
- [18] Danny T. MFA (Multi-Factor Authentication) with Biometrics. 2017. (accessed on 4 Jaurnay 2018).
- [19] Scott Garriss, Michael Kaminsky, Michael J. Freedman, Brad Karp, David Mazières, Haifeng Yu, "RE-Reliable Email".URL:

[https://www.usenix.org/legacy/event/nsdi06/tech/full\\_papers/garriss/garriss.pdf](https://www.usenix.org/legacy/event/nsdi06/tech/full_papers/garriss/garriss.pdf)

[20] Gordon V. Cormack (2008), "Email Spam Filtering: A Systematic Review", Foundations and Trends® in Information Retrieval, Vol. 1: No. 4, pp 335-455. <http://dx.doi.org/10.1561/1500000006> URL: <https://www.nowpublishers.com/article/Details/INR-006>

[21] Human-based Vs Computer-based Social Engineering Prerna Bhajbhujje 1, Rajeshwari Gundla 2, Siddharth Nanda3 1U.G. Student, 2 Senior Faculty, 3 Faculty SOE, ADYPU, Lohegaon, Pune, Maharashtra, India1 IT, iNurture, Bengaluru, India2,3 URL: [https://www.researchgate.net/publication/332151597\\_Social\\_Engineering\\_Attacks\\_A\\_Survey](https://www.researchgate.net/publication/332151597_Social_Engineering_Attacks_A_Survey)

# Wireless Technology Based Fault Diagnosis in Industrial Water Level Control with Temperature Data Remote Monitoring and Recording System using PLC and SCADA

Khaled Hashala\*,  
Dept. of EECE, SSET,  
Sharda University,

Greater Noida, India,

20201816486.khaled@pg.sharda.ac.in\* ,jayachitra.kishor@sharda.ac.in\*

DRT. JAYA CHITRA\*,  
Dept. of EECE, SSET,  
Sharda University,

Greater Noida, India,

**Abstract**—An industrial water level control system is controlled using Allen-Bradley (AB) SLC 500 PLC with SLC 5/05 processor: Programmable Logic Controller, RTX-MID-5V transceivers, converters, RTD sensor with a heater coil, and a pump in control by a powered electrical. The whole system is being monitored and secured by using PLC-interfaced Wonderware In-touch SCADA and also the temperature is being automatically recorded by a third-party database using the data logging feature of SCADA. The water levels are supervised by using system- interfaced indicators. Faults in the system are being instantly monitored by the pop-up generation technique of SCADA and alarm annunciation. So that a fault occurred will be diagnosed quickly with this technique to avoid major losses. Finally, this project implemented and conducted a simulation experiment using AB SLC 500 PLC and SCADA to control described system. The goal of this paper is to diagnose faults that occurred in the system, monitor the system far away from the main control unit, and automatically record the system data using wireless technology. **Key Words** - PLC, Wireless Technology, Fault, Transceiver, Water Level Management, Data Recording, and SCADA.

**Keywords:** SCADA, Industrial, PLC, control, Wireless,

## I. INTRODUCTION

A computer utilized for the automation of mechanical device processes may be referred to as a PLC, PLC, or a programmable controller is a programming logic controller. In order to automate industrial processes, "Relay Logic" or "Wired Logic" is previously converted into "Ladder Logic." Contrary to common computers, PLCs are built to handle wide temperature ranges, Multiple output and input configurations, resistance to electrical noise, toleration of vibration, and tolerance of impact. The SLC 500, CPU SLC 5/04 (Image Processing and Data Execution) ALLEN BRADLEY PLC, 04/09/01 DI/DO/AI is employing in this project. The goal of the "Industrial Water Tank Level Control system by using PLC" project is to keep an eye on and regulate the tank's liquid level. In order to automatically refill the tank when the liquid as it crosses the lower threshold and turns off the pump when the liquid the system is connected to an automatic pumping mechanism that activates when the higher threshold is reached. The availability of sustainable water supplies is currently a major issue in many parts of the world. a lack of effective along with integrated water management, wasteful water consumption, and poor water allocation are the silent causes of this issue. Water is frequently used for home and commercial purposes.,and agriculture. Thus,efficient use,water monitoring, and control may place a cap on the watermanagement system of a home or workplace. making, andimplementation. Thesystemisimplementedwithlevelsensors.

These sensors find water when it is present. The PLC uses the sensor readings to determine whether to make the required call. Lastly, the PLC uses a relay switch to enforce the decision. RX Logix 500 was used to implement the ladder logic. The suggested mechanism will continuously control the tank's liquid level to ensure that there is always sufficient water in the tanks. This system is applicable for industrial use. It can be utilized to avoid industrial accidents caused by overfilling in open containers as well as any closed containers, which would result in an overpressure state. This single system will be able to control many due to the PLC's numerous input and output ports, tanks by itself. As the system is managed by the PLC, there is no need for human intervention, which might save on labor costs and safeguard people from the risk of industrial accidents.

## LITERATURE REVIEW

Authors have designed and developed the Zigbee based Agricultural irrigation systems located between 50 and 100 meters away may benefit greatly from the use of microcontroller-based wireless technology [1] [2]. Describes automatic water control method with fewer manual steps and less potential for mistakes. As technology has advanced, wireless instrumentation has emerged as a means of circumventing the need for hardwired systems and achieving more precise control. But this is designed for 50m-100m distance communication only [3]. With the aid of a programmable logic controller, the suggested system can automatically regulate the water supply. It helps to maintain level in the tank. Continuous monitoring with a SCADA screen connected to the PLC further increases automation [4]. This suggestion the PLC based control system so that there is always enough water in the storage tank to supply the cities needs. With a SCADA system, operators can monitor and adjust the process in real time [5]. Researchers proposed PLC and wireless sensors for controlling water levels. Using Siemens PLC for 100m distance only [6]. Demonstrated an IoT-enabled prototype of an industrial process for taking in RO water, which is PLC-controlled [7]. To keep the liquid level near the reference Using an electromagnetic valve with float sensors to check the level of a liquid, MATLAB, and LABVIEW. Control at two levels was not possible due to the limitations imposed by the float sensor's setup and operation [8]. An automatic water level sensor was made using Arduino, an ultrasonic sensor, and GSM indication. An ultrasonic sensor detected the water level, and the motor turned on and off automatically as a result. The user received an SMS alert [9]. The ping sensor and microprocessor AT89S51 were used in the creation of the water level detecting system. Ping sensors were used to gauge the level of the water, and the transmitter module wirelessly transmitted the data to the receiver module [10]. The prototype was created using LABVIEW, a node MCU, and an ultrasonic sensor. With the use of an ultrasonic sensor, the water level was determined. Node MCU transmitted

the felt the Google Cloud Platform to be valuable. The website was displayed on the front panel of LABVIEW seen, and after that testing the water level by activating the valves.

[11]. There was a system created using the ATMEGA328, an ultrasonic sensor, a buzzer, and Xilinx. There were three tanks and associated ultrasonic sensors. It used an Arduino as a controller. After turning on the system, water started to flow through tank 1, indicating that tank 2 had been full, and the buzzer began to ring when two or more tanks had been filled. Tank 3's level indicator controller turned green once it was filled, noticed and shut off the water. Water wastage was therefore avoided. Using Xilinx ISE, the identical thing was created and put into action on an FPGA. Microcontrollers have not been as effective in automating many water tanks as FPGA [12]. A PIC microcontroller and a water level sensor were used in the creation of the water level detecting and control system. A microcontroller received the data from the water level sensor after it had been designed, processed it, and then started the pump. Moreover, it was possible to monitor water level online [13]. A fuzzy controller in LabVIEW and a PID controller were both used in the system's architecture for controlling water levels. Main objective was to maintain water level at specified fixed point.

The fuzzy controller outperformed the PID in terms of accuracy, robustness, low settling and rising times, and no overshoot [14]. An Arduino UNO, a pump, and an ultrasonic sensor make up the suggested setup.

The water level was measured using an ultrasonic sensor. There was a connection between LabVIEW and Arduino. Water was added to the tank as a result of the Arduino turning pumping on and off in response to the sensor reading, which was also shown on the LABVIEW front panel. Pump damage and energy waste result from turning on the pump when the lower tank is completely dry. This is because, in contrast to the upper tank, the lower tank does not have an ultrasonic sensor [15]. An Arduino, an ultrasonic sensor, an LCD, and a relay were used to create the system. An ultrasonic sensor measures the distance; if it is greater than 30 cm, Arduino turns on the pump and displays the information on the LCD; if it is less than 10 cm, the pump is turned off, and the LCD shows the information [16]. A buzzer, a water pump, a microcontroller, and a water level sensor were used to construct the prototype. The data was then sent by the Bluetooth module to the mobile device. After receiving it from the controller, which had first acquired the water table data from the sensor. An indicator was a buzzer. The sensor is contact type, only has a 4 cm measurement range, when exposed to a moist environment, and has a brief lifespan. Corrosion is significantly accelerated when the probe is powered on constantly.

[17]. Two PIC microcontrollers were used to create the prototype. On the transmitter side and the reception side, respectively, there were two microcontrollers employed. The two were able to communicate thanks to a ZigBee transceiver module. Here, a water level sensor was created using the connecting cables. The conducting strip

detected the water level. Long-term use will cause the metal strip to corrode, and precision is constrained [18].

An ESP8266 Wi-Fi module, an 89S52 microprocessor, and float switches were exposed to create its prototype. Tanks four have to be this was taken in. An element for it was a sense floated. The ESP8266 Wi-

Fimodule received the sensed data and transmitted it, and the module will submit the information to a server.

The microcontroller managed the circuitry for the motor driver and water level sensors. The system employs 16 floating switches.

Because they are contact switches, float switches have poor accuracy and precision and frequently need repair [19]. Design work was done on the capacitive sensors and the signal conditioning circuit. Little was spent on the design.

overall capacitance generated matched the water level in the tank. As deep the water is storage tank must be taken into consideration while designing the sensor's length [20]. A mobile phone, a sensor for water levels, and an Arduino microcontroller were used to develop the prototype. The supervisor, which in turn updates the data on the server, obtained the water's observed level sensor for the level. The mobile phone received the data that was kept on the server. By pushing the mobile device's buttons, the user then chooses whether to switch the motor on or off. It is a sensor with contact. Its measuring range is constrained, and when it is exposed to water, its lifespan is short. Intervention from people is required [21]. Design work was done on the oxidation-reduction potential, pH, conductivity, flow, and temperature sensors. The notification node received the sensor reading from the measuring node over ZigBee and processed it before sending it to the microcontroller in the measuring node for display. Monitoring of the water quality resulted [22].

### III Proposed Methodology

The Fig. 1. as shows below depicts the proposed system's block diagram. Controlling the water level in the tank is an important mechanism in daily operations.

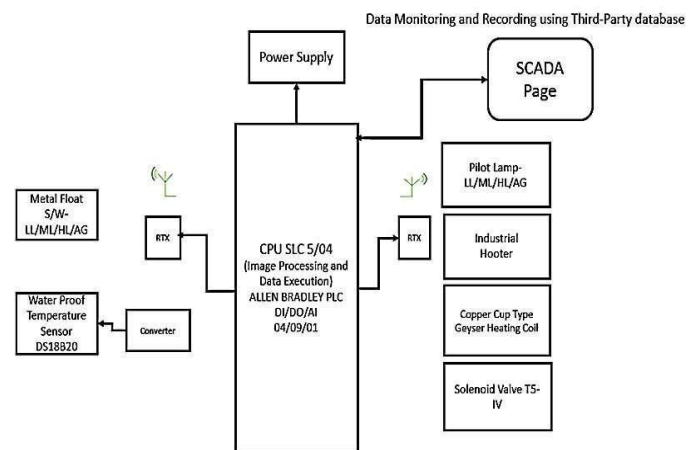

Fig. 1. diagram of industrial water level control system.

In There is a significant amount of water waste in the tank

in many companies, and this project aims to reduce that waste touse a PLC and SCADA to remotely monitor and control thelevel of an industrial water tank as well as the temperature,and also to record the monitored data. The system has an automatic connected pumpingsystem. The pump turns ON and OFF automatically when the tank's water level drops to the point at which it must be filled. In order to manage the water level for industrial purposes, the feed pump is often started at a low level and left running until the water level in the tank rises. To start and stop the motor, though, requires a person, and there is also the possibility of water overflowing and the motor running dry. The water in the tank is then heated by a Copper Cup Type Geyser Heating Coil for different industrial applications like food processing, dairy, pharmaceuticals, etc. The water temperature is sensed by a 1-meter-long water proof sensor. So that a proper range of temperature will be maintained as per the requirements of industrial applications, this temperature data is then recorded by a third-party database, i.e., MS Excel. The PLC must communicate with SCADA software in order to record this. For the early detection of faults, the pop-up generation technique is introduced. This technique helps detect causes of system failure, remedies, and the name of the faulty device instantly. As all the field input and output devices are interfaced through RTX-LR-869MHz transceivers, remote data monitoring is possible upto 3km away.

Water sustainability requires appropriate monitoring, which is possible with PLC-based automated water level detection and control. We are utilizing a PLC, sensor, and motor to automatically manage the water level. The float switch SEN-SSI45 alerts the PLC when it detects a body of water is present. The PLC produces a control signal that is used to run the motor. If the tank is empty, the PLC transmits the signal to start the motor, and if the tank is full, the signal to stop the motor. It also avoids a dry run of the pump in the case that the level in the tank drops below the suction level.

This project automates a water tank by utilizing a level sensor to establish a low level, medium level, and high level within the tank. The Float Switch detects liquids or water up to 120°C. If the high-level float switch fails to operate, the additional float switch is provided in this emergency situation. This allows the system to run without interruption, so there is no need to stop the system immediately, but the industrial hooter issues an alarm when a fault occurs, so the operator is aware of the fault and acknowledges

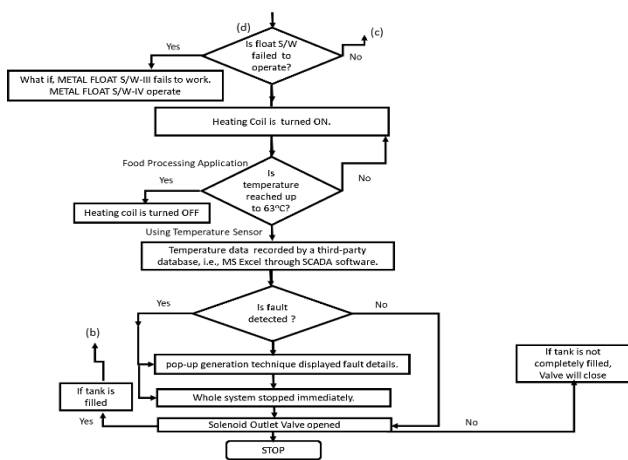

Fig. 2. FLOWSHART AS SEEN ABOVE

VI SLC 500 SYSTEM OVERVIEW

A compact chassis-based line of discrete, analogue, and specialized I/O and peripheral devices as well as programmable controllers is known as the Allen-Bradley SLC 500.

Power and adaptability are provided by the SLC 500 series, which offers a variety of connectivity configurations, capabilities, and memory options. To reduce project development time and increase productivity,

The Programming in RS

Logix 500 ladder logic suite includes a powerful database editor that is adaptable, a point-and-click I/O setup, and diagnostic and troubleshooting tools. Giving 64K of programmable data/program memory, more than 60 different types of I/O modules, and a variety of networking options, the SLC system provides an efficient a networked or stand-alone industrial control solution.

modular equipment A CPU module, I/O modules, and a power supply must all be housed in a single 1746 chassis for the SLC 500 control system. One, two, or three local chassis can be used to construct a system for up to 30 local communication or I/O modules. From one local chassis to another, the backplane signal lines will be expanded. connect several local chassis via

ControlNet, Device Net, and Universal Remote I/O networks, by installing an I/O scanner module.

Single-slot modules called SLC 500 processors are installed in the one of the 1746 I/O chassis' leftmost slots. The I/O adapter is a module with a single slot. install in the I/O chassis' leftmost slot to enable I/O in a location far away processing from. Separate power sources are provided by SLC 500 modular systems and The 1746 I/O chassis' left end must be directly positioned on it. The dimensions of the I/O chassis for 1746—which have 4, 7, 10, or 13 module slots—are intended for placement on the backpanel. The maximum channel density for the 1746 I/O modules is 32 channels per module. For communication using Ethernet/IP, DH+, DH-485, or RS-232 (DF1, ASCII, or DH-485 protocol), each CPU has one or two built-in ports.

VII CONCLUSION

In various applications, including the chemical industry, home, pharmaceutical industry, nuclear power plants, etc., water level, temperature monitoring and data recording are crucial factors. This study wraps up a survey of the research on water level control system utilizing papers from several international conferences and journals. The goal of this study can be achieved using the suggested methods. If accomplished, it contributes to conserving both manpower and electricity. Diagnosis of the faults that occurred in the water level control system can be detected soon by showing remedies, name of fault and causes of failure. Temperature data can be monitored and recorded accurately using wireless technology using data logging.

March, 2019.

## REFERENCES

- [1] K. Chakraborty, M. G. Choudhury, S. Das, and S. Paul, "Development of PLC-SCADA based control strategy for water storage in a tank for a semi-automated plant," *J. Instrum.*, vol. 15, no. 4, 2020, doi: 10.1088/1748-0221/15/04/T04007.
- [2] Y. Alward and M. A. Ansari, "Industrial automation and control system development using different approaches," *J. Inf. Optim. Sci.*, 2020, doi: 10.1080/02522667.2020.1721631.
- [3] M. A. Ali, A. H. Miry, and T. M. Salman, "IoT Based Water Tank Level Control System Using PLC," in *Proceedings of the 2020 International Conference on Computer Science and Software Engineering, CSASE 2020*, 2020, doi: 10.1109/CSASE48920.2020.9142067.
- [4] S. S. Thenge, D. A. Patil, A. R. Sangle, and K. C. Mule, "Design and Implementation of Water Level Management Using PLC and SCADA Visualization," *Int. J. Adv. Res. Electr. Electron. Instrum. Eng.*, vol. 6, no. 4, pp. 1–3, 2017, doi: 10.15662/IJAREEIE.2017.0604061.
- [5] M. . Dhvani Parekh; Kaushik Bhuiya; Kilaru Laxmi Sahiti; Kintali Anish; Mr. G Joselin Retna Kumar, "Low Cost Wireless Control and Monitoring of Batch Process Using Plc and Scada," *Int. J. Sci. Res. Publ.*, vol. 3, no. April 2012, pp. 1–4, 2013.
- [6] B. Ritesh and A. Jabeena, "A design and development of smart wireless sensor network for farming water supply system," *Int. J. Appl. Eng. Res.*, vol. 11, no. 5, 2016.
- [7] C. Illes, G. N. Popa, and I. Filip, "Water level control system using PLC and wireless sensors," in *ICCC 2013 - IEEE 9th International Conference on Computational Cybernetics, Proceedings*, 2013, doi: 10.1109/ICCCyb.2013.6617587.
- [8] A. Ahmad, V. Redhu, U. Gupta, nd Year, and L. Devi, "Liquid Level Control By Using Fuzzy Logic Controller," *Int. J. Adv. Eng. Technol.*, vol. 4, no. 1, 2012.
- [9] A. Roy, K. Pratap Singh, and A. Kumar, "Automatic Water Level Indicator Using Ultrasonic Sensor and Gsm Module," vol. 4, no. 5, pp. 261–269, 2018, [Online]. Available: www.ijariie.com
- [10] S. Jatmiko, A. B. Mutiara, and M. Indriati, "Prototype of water level detection system with wireless," *J. Theor. Appl. Inf. Technol.*, vol. 37, no. 1, 2012.
- [11] A. Charles, C. Ayyulusamy, J. Deepak Raj, K. Kumar, and K. Thiruvarasan, "Iot Based Water Level Monitoring System Using Labview," *Int. J. Pure Appl. Math.*, vol. 118, no. 20, 2018.
- [12] L. Adewale Ajao, B. OlatundeAbisoye, J. Agajo, A. Olorundare Ajao, M. Bashir Mua, and A. Femi Salami, "Automated Multiple Water Tanks Control System Using ATMEGA and FPGA Technology," no. March, 2019.
- [13] S. M. K. Reza et al., "Microcontroller Based Automated Water Level Sensing and Controlling: Design and Implementation Issue," *World Congr. Eng. Comput. Sci. Vols 1 2*, vol. I, 2010.
- [14] L. AbedSabri and H. Ahmed AL-Mshat, "Implementation of Fuzzy and PID Controller to Water Level System using LabView," *Int. J. Comput. Appl.*, vol. 116, no. 11, 2015, doi: 10.5120/20378-2599.
- [15] R. M. Shrenika, S. S. Chikmath, A. V. Ravi Kumar, Y. V. Divyashree, and R. K. Swamy, "Non-contact Water Level Monitoring System Implemented Using LabVIEW and Arduino," in *Proceedings - 2017 International Conference on Recent Advances in Electronics and Communication Technology, ICRAECT 2017*, 2017, doi: 10.1109/ICRAECT.2017.51.
- [16] D. Preethi, J. Anusha, M. V. Sravani, R. Puviarasi, and M. Sindhu Bala, "Automatic water level controller," *Int. J. Appl. Eng. Res.*, vol. 10, no. 33 Special Issue, pp. 26581–26587, 2015.
- [17] T. Asha and V. Srija, "Design and Implementation of Wireless Based Water Level Monitoring System Using Arduino and Bluetooth," *Int. Res. J. Eng. Technol.*, vol. 7, no. 1, pp. 745–749, 2020.
- [18] L. Lu, R. Lewis, M. Hu, and R. Lin, "Design and Implementation of a Wireless Networked Water Level Control System," *J. Comput. Commun.*, vol. 03, no. 05, 2015, doi: 10.4236/jcc.2015.35020.
- [19] "Multilevel Water Level Control and Monitoring of Multiple Tanks," *Int. J. Adv. Sci. Res. Eng.*, 2018, doi: 10.7324/ijasre.2018.32582.
- [20] K. Loizou, E. Koutroulis, D. Zalikas, and G. Liontas, "A low-cost capacitive sensor for water level monitoring in large-scale storage tanks," in *Proceedings of the IEEE International Conference on Industrial Technology*, 2015, vol. 2015-June, no. June, doi: 10.1109/ICIT.2015.7125295.
- [21] S. Shankar and M. Dakshayini, "IoT-Mobile Enabled Smart Water Level Controlling System to Regulate Water Wastage," in *2018 International Conference on Advances in Computing, Communications and Informatics, ICACCI 2018*, 2018, doi: 10.1109/ICACCI.2018.8554373.
- N. A. Cloete, R. Malekian, and L. Nair, "Design of Smart Sensors for Real-Time Water Quality Monitoring," *IEEE Access*, vol. 4, 2016//ACCESS.2016.2592958.

# Hardware (Sensor) for E-Bicycle

DR. A V Patil<sup>1</sup>

Dr. DY Patil Institute of Engineering Management and Research,  
Akurdi Pune  
Department of Electronics & Telecommunication  
principal@dypiemr.ac.in

Muazama Shaikh<sup>2</sup>

Dr. DY Patil Institute of Engineering Management and Research,  
Akurdi Pune  
Department of Electronics & Telecommunication  
muazamashaikh@gmail.com

Atharva Deshmukh<sup>3</sup>

Dr. DY Patil Institute of Engineering Management and  
Research,  
Akrudi, Pune  
Department of Electronics & Telecommunication  
2001atharvadeshmukh@gmail.com

Dipshikha Chavan<sup>4</sup>

Dr. DY Patil Institute of Engineering Management and  
Research,  
Akrudi, Pune.  
Department of Electronics & Telecommunication  
dipshikhachavan4@gmail.com

**Abstract:** The demand for Sustainable and eco-friendly travel options has taken a hike. Electric Bicycles are becoming mainstream in the European market with such a developing cycling culture in the European market and other parts of the World. By identifying the market and the demand we in this paper will explore the hardware sensors used in e-bicycles which is an important aspect for any cyclist. An e-bicycle are basically equipped with an electric motor which provides assistance to the rider. This makes cycling easy and comfortable. Sensors are basically used to detect or measure a physical property and respond or indicate about the same. Sensors for e-bicycles are used for monitoring, controlling and safety purposes. Sensors can help to improve the performance of the e-bicycle. By measuring the speed, torque, and orientation of the e-bicycle, the motor provides assistance more efficiently which gives a smoother and comfortable ride. Moreover it can help to prolong the life of e-bicycle by monitoring the charge of batteries and avoid overcharging. Also Sensors can improve safety by detecting the when the brakes are applied and can cut off the power assistance so as the rider does not lose the control on the bike. Various Sensors which we have used include are cadence sensor which determines how fast or slow the cyclist is pedaling. It will apply power based on the pedal assist level. Another sensor which we have used is a Tilt sensor which is a type of position sensor which is used to measure the angle and the slope of the object. Along with this we have used other sensors as well which are interfaced with the STM 32 nucleo Microcontroller. Sensors can help improve the performance and safety of the bicycle giving a plus point for cyclists to travel efficiently.

**Keywords—** E-Bicycle, Sensors, STM, Microcontroller, Tilt sensor, LCD Display.

## I. INTRODUCTION

The world population as well as the traffic is increasing enormously and it has become a daily challenge faced by everyone to Travel. Carrying out basic activities has become difficult, and a solution to this problem needs to be there. Many of which found a way to tackle just problems e- Bicycles are a highly efficient means of transport. An Electric Bicycle is a

Bicycle with a motor attached to it that give assistance to the rider they have been in demand and became mainstream as they are environmentally friendly and a cheap, efficient, and healthy way of travel. It is a more comfortable and easier form of the bicycle that overcomes the disadvantages of a regular bike. E-bicycles have the potential to become the one of best means of mobility. They are an excellent means of transportation since they mix the convenience of a bike with the riding. Pedal-assist bicycles are becoming the most practical alternative for shorter distances'-bicycle are an eco-friendly option than traditional bikes as they emit carbon into the atmosphere. The rising popularity of e-bicycle is benefiting the sector due to lower ownership and maintenance costs. Advancements in charging infrastructure and demand in the European market makes e-bicycle markets a huge profit making product. The European market is further expected to grow nearly USD 58.85 billion by 2028. People prefer e-bicycle as an easy, cheap, and safer way to commute, thereby contributing to market growth. Sensors play a vital role the use of sensors is an important component of e-bicycles. By measuring speed, torque, battery charge, brake application, and orientation sensors can improve the performance, safety, and lifespan of e-bicycles. As e-bicycles continue to gain popularity as a sustainable and eco-friendly mode of transportation, the development and use of sensors will continue to play a crucial role in their success. Each sensor integrated will work to make the E-Bicycle work as per our desire. As our Bicycle is pedal assist cadence plays an important role to make it work.

The output of cadence will be given as input to the motor drivers based on which it will drive the hub motors to rotate the shaft. The ultrasonic sensor placed on each side of the E-Bicycle will sense the vehicle coming towards them and vibrate the module mounted in the throttle of the bicycle to alert the driver about incoming vehicles. MPU6050 aka tilt sensor will measure the inclination angle of E- Bicycle. The speed sensor will give us the real-time speed of the E-Bicycle. It is also used to add the speed limit to the bicycle to avoid any kind of accident. A temperature sensor is mounted near the batteries to alert the driver if the temp of the battery is going too high.

## II. Block Diagram &amp; Components

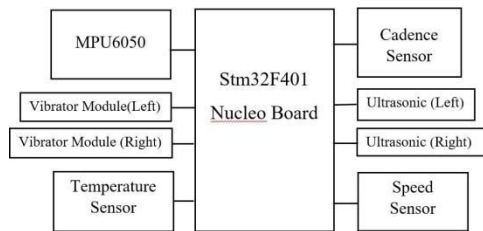

The sensor used in Hardware for e-Bicycle are listed below:

- A. Cadence Sensor
- B. MPU6050
- C. Ultrasonic sensor
- D. Vibrator Module
- E. LCD Display

#### A. Cadence sensor:

Cadence sensors are a popular tool used in cycling to measure a cyclist's pedaling rate in revolutions per minute (RPM). The methodology for using a cadence sensor typically involves a few basic steps. First, the cadence sensor must be installed on the bike, usually on the non-drive side of the crank arm. It is then paired with a compatible cycling computer or smartphone app. Once the sensor is installed and paired, the cyclist can begin cycling. The cadence sensor will detect each revolution of the pedals and transmit the data to the cycling computer or app in real-time. The cyclist can monitor their cadence using the display on the cycling computer or app. This allows them to adjust their pedaling speed and maintain a consistent cadence throughout their ride. After the ride, the cyclist can review the data collected by the cadence sensor to analyze their performance. This may include identifying areas where cadence could be improved, such as maintaining a consistent cadence on hills or during sprints. Overall, using a cadence sensor is a straightforward process that can provide valuable insights for improving cycling performance.

The Cadence sensor we are using is KTV12L:



**Fig 1:** Cadence Sensor

The KTV12L is a cadence sensor that is commonly used in bicycles to measure the rate at which the rider is pedaling. It is a magnetic sensor that detects the rotation of the bicycle's crank arm, and outputs a digital signal that changes state with each revolution of the pedals. The KTV12L sensor is compact in size and lightweight, making it easy to install on the bicycle's frame or crank arm. It has a sensing distance of 2-

5mm, and an operating temperature range of  $-20^{\circ}\text{C}$  to  $+60^{\circ}\text{C}$ . The sensor is powered by 5V DC and has a low current consumption of less than 10mA. The KTV12L sensor is compatible with most bicycle computers and other cadence sensor systems, and can be used to track the rider's cadence in real-time. By monitoring the cadence, cyclists can optimize their performance and improve their training, leading to better fitness and overall Health.

The KTV12L cadence sensor is a magnetic sensor designed for use in bicycles. It is commonly used to measure the cadence of the pedals, which is the rate at which the rider is pedaling. Here are the general specifications of the KTV12L sensor:

Type: Magnetic sensor

Output signal: Digital signal (changes state with each revolution of the pedals)

Operating voltage: 5V DC

Current consumption : <10mA

Maximum sensing distance: 2-5mmable

Cable Length: 900mm

Operating temperature:  $-20^{\circ}\text{C}$  to  $+60^{\circ}\text{C}$

Housing material: ABS

Weight: 8g

Dimensions: 21mmx 16mm x 8mm

The KTV12L sensor can be easily mounted on the bicycle frame or crank arm, and is compatible with most bicycle computers and other cadence sensor systems. Its compact size, low power consumption, and easy installation make it a popular choice for many cycling applications.

#### B. MPU6050:

The MPU6050 is a commonly used microelectromechanical system (MEMS) sensor module that combines a 3-axis gyroscope and a 3-axis accelerometer in a single compact package. It is manufactured by InvenSense, which is now part of TDK Corporation. The MPU6050 sensor module can be used in a wide range of applications, including motion tracking, gesture recognition, gaming, and robotics. It is particularly popular in drone and quadcopter projects due to its small size, low power consumption, and high accuracy. The MPU6050 measures rotational and linear motion in three dimensions. The gyroscope measures angular velocity in degrees per second ( $^{\circ}/\text{s}$ ), while the accelerometer measures acceleration in g units (where 1 g is equal to  $9.81 \text{ m/s}^2$ ). The sensor module is connected to a microcontroller or other processing device using an I2C serial interface. This allows the device to read data from the sensor, configure its settings, and perform calibration if necessary. One of the key features of the MPU6050 is its ability to perform sensor fusion. By combining data from the gyroscope and accelerometer, the sensor module can provide more accurate and stable orientation information, even in challenging environments with vibrations or rapid movements. Overall, the MPU6050 is a very reliable sensor module that can be used in a wide range of applications making it a very useful sensor. Its combination of gyroscope and accelerometer sensors, small size, low power consumption, and easy interfacing make it a popular choice for many projects.

The MPU6050 is a sensor module that combines a 3-axis gyroscope and a 3-axis accelerometer in a single package. It is commonly used in motion-based projects, such as gaming controllers, drones, and robots. The MPU6050 can measure rotational and linear motion, making it a popular choice for applications that require accurate motion tracking. The gyroscope measures the rate of rotation around the X, Y, and Z axes, while the accelerometer measures acceleration in the X, Y, and Z directions.

The sensor module also includes a Digital Motion Processor (DMP), which provides a powerful motion processing engine for complex motion tracking and gesture recognition algorithms. The DMP can offload some of the computational tasks from the main microcontroller, allowing for more efficient processing of motion data. The MPU6050 uses a digital interface, such as I2C or SPI, to communicate with the host microcontroller. It is designed to operate over a wide range of power supply voltages and can be easily integrated into various applications. Overall, the MPU6050 is a reliable and versatile sensor module that provides accurate motion tracking and acceleration sensing capabilities.

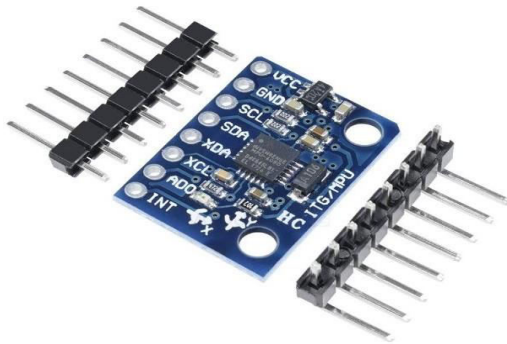

**Fig 2:**MPU6050

### C. Ultrasonic Sensor

An ultrasonic sensor is a type of sensor that uses high-frequency sound waves to detect the distance to an object. The sensor works by emitting sound waves at a frequency above the range of human hearing, typically around 40 kHz. The sound waves then bounce off of objects and return to the sensor, where they are detected and used to determine the distance to the object.

Ultrasonic sensors are commonly used in a variety of applications, such as in robotics, automotive parking systems, and industrial automation. They are preferred over other types of sensors because they are non-contact, meaning they do not physically touch the object being detected, and they are not affected by the color, texture, or material of the object. Ultrasonic sensors come in different types, including proximity sensors, distance sensors, and level sensors. Proximity sensors are used to detect the presence of objects within a specific range, while distance sensors are used to measure the distance to an object. Level sensors, on the other hand, are used to detect the level of liquid or solid material in a container.

Ultrasonic sensors have several advantages over other types of sensors. They are accurate, reliable, and have a high resolution. However, they do have some limitations. For example, they are not suitable for use in environments with high levels of ambient noise, and they may have difficulty detecting objects that are small or have irregular shapes. Overall, ultrasonic sensors are a useful and versatile type of sensor that can be used in a wide range of applications.

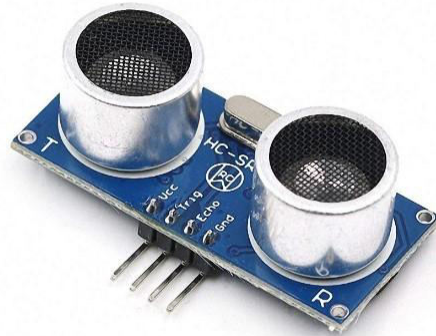

**Fig 3:** Ultrasonic sensor

An ultrasonic sensor typically consists of a transmitter and a receiver. The transmitter emits high-frequency sound waves, which bounce off objects and return to the receiver. By measuring the time it takes for the sound waves to travel to the object and back, the sensor can determine the distance to the object.

Ultrasonic sensors have a number of advantages for use in e-bicycles. They are relatively inexpensive, lightweight, and consume very little power. They can also be used in a wide range of weather conditions and are not affected by light or interference.

One common application of ultrasonic sensors in e-bicycles is for obstacle detection. By mounting sensors on the front or rear of the bicycle, the rider can be alerted to the presence of obstacles such as other vehicles, pedestrians, or stationary objects. Another use for ultrasonic sensors in e-bicycles is for distance measurement. By measuring the distance to an object, the sensor can provide useful information to the rider, such as the remaining distance to a destination or the distance to the next turn on a route.

### D. Vibrator Module

A vibrator module can be used in an electric bicycle as a way to provide haptic feedback to the rider. This is typically achieved through the use of a small motor that is connected to the bicycle's controller. When the motor is activated, it produces a vibration that can be felt by the rider through the handlebars or seat.

This can be useful in a number of ways, such as providing feedback when the power assistance level changes, indicating when the battery level is low, or warning the rider of potential hazards such as obstacles or rough terrain. The vibrator module can also be used in combination with the LCD display to

provide additional feedback to the rider. For example, the motor could be programmed to vibrate in a specific pattern or frequency to indicate a particular message on the display, such as a turn-by-turn navigation instruction or a warning message. Overall, the use of a vibrator module in an electric bicycle can enhance the rider's experience by providing haptic feedback that is more immediate and intuitive than visual or auditory cues alone.

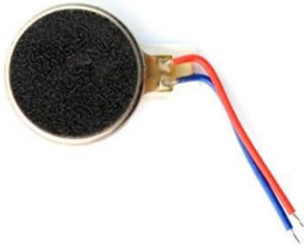

**Fig 4:** Vibrator Module.

When an electrical current is delivered, a little motorised device called a vibrator module causes vibrations. Electronic gadgets frequently employ it to deliver haptic feedback or vibration warnings. The standard structure of a vibrator module is an eccentric weight coupled to the shaft of a tiny electric motor. The weight causes the module to vibrate when the motor turns, giving the user a tactile feeling. Many electronic gadgets, such as mobile phones, gaming controllers, wearable technology, and medical equipment, contain vibrator modules. These can serve a number of functions, including as giving tactile feedback when a button is pressed, letting users know when calls or messages are coming in, and alerting them to alerts or notifications.

Several vibrator modules are available. We have used a Mini vibrator.

Mini vibration motors with a diameter of 2.7mm are small and compact devices commonly used in electronic devices such as mobile phones, wearables, and medical devices. Here are some specifications that are typical for this type of motor:

Diameter: 2.7mm  
 Length: 4mm to 6mm  
 Operating voltage: 1.5V to 3.7V  
 Current consumption: 50mA to 100mA  
 Vibration amplitude: 0.2mm to 0.8mm  
 Frequency: 10,000 to 15,000 RPM  
 Weight: 0.07g to 0.1g  
 Noise level: 50dB to 60dB.

#### *E. LCD Displays*

A 5-inch RGB capacitive touch LCD module is a display module that has a 5-inch screen with a resolution of 800x480 pixels and a capacitive touch interface. This type of display module is compatible with Atom/Wildfire STM32 development

boards, which are microcontroller development boards based on the STM32 microcontroller architecture. The LCD module can be connected to the development board using various interfaces, such as SPI, I2C, or RGB. The module typically includes an on-board controller that drives the display and manages the touch interface. The controller can be programmed using the development board's software development kit (SDK) to customize the display and touch functionality. The module also features an RGB interface that supports 16 million colors, allowing for vibrant and colorful displays. It may also have additional features such as a built-in backlight, a built-in temperature sensor, and a built-in ambient light sensor. The capacitive touch interface allows for intuitive and responsive touch input, similar to that of a smartphone or tablet. This interface can support multi-touch input, allowing for more advanced touch based interactions. Overall, the 5-inch RGB capacitive touch LCD module is a versatile and powerful display module that can be used in a variety of applications, particularly in projects involving Atom/Wildfire STM32 development boards.



**Fig 5:** LCD Display.

Here are the specifications for a typical 5-inch RGB capacitive touch LCD module compatible with Atom/Wildfire STM32 development board:

#### Display-:

Screen size: 5 inches Resolution: 800 x 480 pixels  
 Interface: RGB  
 Colors: 16 million

#### Touch interface-:

Type: Capacitive  
 Multi-touch: Yes

#### Controller-:

Type: On-board  
 Features: Display and touch control Power: Input voltage: 5V  
 Power consumption: 200-300mA

#### Additional features-:

Backlight: Yes  
 Temperature sensor: Yes  
 Ambient light sensor: Yes

Atom/Wildfire STM32 development board Overall, this type of LCD module offers a high-resolution display and a responsive capacitive touch interface. The built-in controller simplifies the interface with the development board, and

additional features such as a backlight and sensors enhance its capabilities. The compatibility with Atom/Wildfire STM32 development boards make it a suitable choice for a variety of project

### III. Methodology

The sensors are interfaced with STM32f401 Nucleo Microcontroller. The output from the cadence will be given to the motor driver in the form of a PWM signal and its calculated voltage. The motor driver based on this voltage will give power to the hub motors to run accordingly. The E-Bicycle will operate in 3 different modes. In the first mode also known as the low power mode the battery voltage will be 25%. In the 2nd mode, the battery will operate at 75%. In the third mode, the output of the battery will be 100%. The 4th mode will be when the battery percentage is less than 20% it will go into low power mode and the E-Bicycle will operate at a minimum speed set before. The speed sensor will give us the real-time speed of the E-Bicycle which will be displayed on the LCD Display Board. It will limit the speed of the vehicle to avoid any kind of accident.



**Fig 6:** Cadence on DSO.

The ultrasonic sensors mounted on each side of the backside of the E-Bicycle will sense the vehicles coming towards in its direction and will give output to the respective vibrator module. If the vehicle is approaching from the left side the left ultrasonic sensor will sense the object and will make the module vibrate which is installed in the throttle of the bicycle. Similarly, when the vehicle is approaching from the right side throttle will vibrate to let the driver know from which side the vehicle is coming from behind. This will ease the driving experience.

MPU6050 i.e. Tilt Sensor also known as inclinometer will check the angle or slope at which the E-Bicycle will lean down the road. A temperature sensor mounted near the battery will give us the real-time temperature so that the driver may get alert when the battery temp is going too high.

### V. Applications

E-bicycles, or electric bicycles, have become increasingly popular in recent years due to their ease of use and eco-friendliness. Here are some ways e-bicycles can be applied in our daily life.

- **Commuting:** E-bicycles can be a great alternative to driving or taking public transportation for short to medium distance commutes. They allow you to get to your destination quickly and easily without contributing to air pollution.

- **Exercise:** E-bicycles can also be used as a form of exercise, particularly for those who may not be able to engage in more strenuous physical activities.

- You can adjust the level of electric assistance to suit your needs and gradually increase your fitness level.
- **Recreation:** E-bicycles can be used for leisure activities such as cycling tours, exploring nature trails, and visiting parks or beaches.
- **Delivery services:** E-bicycles are being used by businesses such as food delivery services and couriers to transport goods quickly and efficiently, while reducing their carbon footprint.
- **Mobility aids:** E-bicycles can also be used as a mobility aid for individuals with disabilities or limited mobility, allowing them to travel further distances and maintain their independence.
- Overall, e-bicycles have numerous applications in our daily lives and can provide a convenient, cost-effective, and environmentally friendly transportation option.

### VI. Results

With our Sensors being deployed in E-bicycle it would give the user a great experience, comfort, ease of Travelling ,eliminating use of fuel which could eventually reduce environmental pollution and many more beneficial experiences.

- The Cadence sensor being used gives a correct input to the hub motor which then drives the shafts.
- Other sensors/components like Ultrasonic sensor, MPU6050, LCD display gives accurate results.
- Ultrasonic sensor being used tells us if any vehicle is close to us it does make the left side of the handlebars vibrate when the sensor senses a vehicle close to the left side of it and if the vehicle is on the right it gives a vibration on the right side.
- MPU6050 being deployed does help us measure the tilt of our e-bicycle. Fall detection can be sensed by MPU6050.
- LCD Display displays all the information about our e-bicycle real time Battery percentage, real time Speed, Time, Battery Temperature, etc.

### VII. Conclusion

The aim of this research paper is to make the use of sensors for making our Bicycles for traveling smoother. We came around various types of sensors while working for this project with their specifications and in the end list out the one which are required. All the sensors/hardware used to make this e-bicycle are the efficient and reliable one specifically chosen for the features we want in our e-Bicycle. In conclusion, the use of hardware sensors in e-bicycles has revolutionized the way we ride and interact with our bikes. The incorporation of sensors such as torque sensors, speed sensors, and cadence sensors has significantly improved the overall riding experience, making e-

bicycle more efficient, safer, and easier to use. These sensors enable the rider to monitor their performance and regulate the

assistance provided by the motor, leading to a more intuitive and responsive ride. Furthermore, the integration of sensors with modern technology has allowed for the development of smart e-bicycles that can communicate with other devices and provide useful information about the bike and its surroundings. While there is still room for improvement in terms of accuracy and reliability, the potential benefits of using hardware sensors in e-bicycles are undeniable, and we can expect to see continued advancements in this field in the years to come.

#### VIII. References

- [1] Bern J.E. Misgeld, Lukas Bergmann, Bence Szilasi, Steffen Leonhardt, Dietmar Greven. "Virtual torque sensor forelectrical bicycle" in *IFAC-Papers Online* volume 53.
- [2] Khan, S.; Pathan, A.-S.K.; Alrajeh, N.A. "Wireless Sensor Networks: Current Status and Future Trends" Taylor & Francis: Abingdon, UK, 2013; ISBN 9781466506060.
- [3] S Khaleghi, B.; Khamis, A.; Karray, F.O.; Razavi, S.N. "Multisensor data fusion: A review of the state-of-the-art. *Inf. Fusion*" 2013, 14, 28–44.
- [4] Esther Salmeron-Manzano and d Francisco Manzano-Agugliaro "The Electric Bicycle: Worldwide Research Trends" Faculty of Legal, Social and Human Sciences, Universidad Internacional de La Rioja (UNIR).  
Published: 20 July 2018
- [5] MUETZE, Y.C TAN "Performance Evaluation of Electric Bicycles" Electrical and computer Engineering Department University of Wiaconsin-Madison, WI 53706, USA.
- [6] Ravi Teja Ch.v, Ch.Pujitha, S.Gayatri, V.Jalander, Ch.Kavithar, "Sensor Based E-Bicycle for College Campus". Department of Electronics and Communication Engineering, Anurag college of engineering, Hyderabad, Telangana, India. *International Journal of Scientific and Research Publications*, Volume 6, Issue 4, April 2016 531 ISSN 2250-3153
- [7] Ian Vince McLoughlin, I. Komang Narendra, Leong Hai Koh, Quang Huy Nguyen, Bharath Seshadri, Wei Zeng, Chang Yao Yao "Campus Mobility for the Future: The Electric Bicycle" School of Computer Engineering & Energy Research Institute, Nanyang Technological University, Nanyang Avenue, Singapore, November 6 2011.
- [8] Yashwant Sharma, Oraveen Banker, Yogesh Raikwar, Yogita Chauhan, Madhvi Sharma "R&D On Electric Bike" *International Research Journal of Engineering and Technology (IRJET)* Volume:05 Issue:02| Feb-2018.
- [9] Sanjeeb kumar Pattanayak, Milan Tirkey, Pramod Lakra, Vivek Ranjan, soumya Ranjan Panda, Manas Ranjan Panda. "Electric Bicycle" April 2017 *IJSDR* | Volume 2, Issue 4
- [10] Ranjan Kumar, Munna Kumar, Pradyumn Sah, Mustaim Alam "Design and Fabrication of Electric Bicycle" *International Journal of Engineering Research & Technology (IJERT)* ISSN: 2278-0181 Published by, www.ijert.org *ETEDM - 2018 Conference Proceedings*.

# WIRELESS ELECTRIC VEHICLE CHARGING SYSTEM USING SOLAR

Prof. M.K.Bhosale<sup>1</sup>, Shivraj Kete<sup>2</sup>, Ritika Binzade<sup>3</sup>  
 TPO, Department of Electronics and Telecommunication<sup>1</sup>  
 Students, Department of Electronics and Telecommunication<sup>2,3</sup>  
 Sinhgad Institute of Technology, Lonavala, Maharashtra, India

mbhosale.sit@sinhgad.edu  
 keteshivraj.sit.entc@gmail.com  
 ritikabinzade.sit.entc@gmail.com

**Abstract:** *This paper presents a design for a solar-powered charging station that can charge electric vehicles without the need for wires or external power. Electric vehicles are becoming increasingly popular due to their environmental benefits and cost savings over traditional gasoline-powered cars. However, one of the major drawbacks of electric vehicles is the need to stop and charge the battery, which can be inconvenient for drivers. Our innovative charging system solves this problem by allowing vehicles to charge while they are in motion on the road. [5]*

*The system consists of several components, including a solar panel, battery, transformer, regulator circuitry, copper coils, AC to DC converter, atmega controller, and LCD display. By using these components, the system is able to wirelessly charge electric vehicles as they move along the road, eliminating the need for drivers to stop and charge their vehicles.[1]*

*Our solar-powered wireless charging system has the potential to be integrated into the road infrastructure and provide a sustainable solution for charging electric vehicles. By using renewable solar power, our system also helps reduce transportation's environmental impact.*

**Keywords:** Battery; Micro Controller; Embedded System; Transformer; Microprocessor; Electric Vehicle;[2]

## I. INTRODUCTION

Electric Vehicles (EVs) are a rapidly growing trend in the transport sector around the world. According to projections, the market share of EVs will continue to grow and could comprise 24% of the U.S. light vehicle fleet by 2030, representing 64% of light vehicle sales that year. However, the proliferation of EVs will require regulation of the battery charging process to maintain power quality in the power grids. On the other hand, the large amount of energy stored in EV batteries creates an opportunity for energy flow in the opposite direction.[6] In the future, the interactivity between EVs and smart grids will be key to contributing to the autonomous operation of the power grid. This can be achieved through the use of onboard bidirectional chargers with V2G (vehicle-to-grid) and V2H (vehicle-to-home) technology. Despite the benefits of EVs, such as lower carbon dioxide emissions and reduced reliance on fossil fuels, they have not been widely

adopted due to some limitations. These limitations include high vehicle costs, limited charging infrastructure, and limited all-electric range. EVs are vehicles that are either partially or fully powered by electric power, which results in low running costs due to fewer moving parts for maintenance and high environmental friendliness as they use little or no fossil fuels.[2,3]

## II. MOTIVATION

As we move towards a more sustainable future, there is an increasing demand for renewable energy sources. Solar power is one of the most abundant and clean sources of energy available today. Using solar power to charge electric vehicles can reduce our dependence on fossil fuels and decrease our carbon footprint. Wireless charging eliminates the need for cables and connectors, making charging their vehicles more convenient for EV owners. This can increase the adoption of electric vehicles, as it removes one of the perceived barriers to ownership. Electric vehicles (EVs) are already an eco-friendly alternative to gasoline-powered vehicles because they produce zero emissions when they are being driven. However, the energy used to charge EVs can still come from non-renewable sources like coal and natural gas. By using a solar-powered charging system, the entire process becomes much more sustainable and environmentally friendly.

## III. PROBLEM STATEMENT

Electric vehicles (EVs) use one or more electric motors, also known as traction motors, for propulsion. These vehicles can be self-contained using various power sources such as batteries, solar panels, fuel cells, or an electric generator that converts gasoline to energy from an off-vehicle collector system. Different types of electric vehicles exist, including hybrid and all-electric cars, trucks, trains, ships, planes, and spacecraft. Historically, electricity was a popular mode of vehicle propulsion due to its comfort and operational convenience, which gasoline-powered vehicles couldn't match. While internal combustion engines have dominated vehicle propulsion for over a century. Electric power is still commonly used in trains and other small vehicles

## IV. LITERATURESURVEY

No.	TITLE	AUTHOR	METHODOLOGY
1	SOLAR WIRELESS ELECTRIC VEHICLE CHARGING SYSTEM	<u>BRV Prasad, M Geethanjali, M Sonia, S Ganeesh</u>	The present paper presents the design of a solar-powered charging station for electric vehicles that aims to address the environmental and economic issues associated with traditional fuel-powered vehicles. With the increasing number of electric vehicles on the roads globally, it has become imperative to develop sustainable and efficient charging solutions. This solar-powered charging station provides a unique and innovative solution to this problem by enabling the charging of electric vehicles without the need for wires or stopping the vehicle.
2	SOLAR WIRELESS ELECTRIC VEHICLE CHARGING SYSTEM	<u>Karim, Merazul Shafiq, Nahian Bin Zame, Tousif-ul Islam Hossain, MD.Sakib Shawon, Mehedi Azad</u>	As electric vehicles gain popularity worldwide, countries are finding ways to promote them by investing in charging infrastructure. This not only benefits the environment but also reduces transportation costs by replacing expensive fuels with cheaper power. We propose an innovative solution to address this need by designing a charging infrastructure that allows vehicles to charge on the go using solar energy. This system eliminates the need to stop charging and eliminates the need for an additional power source.
3	Wireless charging systems for electric vehicles	Muhammad Amjad , Muhammad Farooq -i-Azam	Then, the specific methods and techniques used for wireless charging in electric vehicles are discussed. These include inductive charging, resonant charging, and capacitive charging. The advantages and disadvantages of each method are analysed, and their suitability for different types of electric vehicles is discussed. The challenges and limitations of wireless charging are also discussed, including issues related to efficiency, safety, and compatibility with different types of vehicles. Finally, the paper concludes with a discussion of future directions for wireless charging research and development, including the potential for integrating wireless charging with other emerging technologies such as autonomous driving and vehicle-to-grid systems. Overall, the paper highlights the potential of wireless charging to revolutionize the electric vehicle industry and accelerate the transition to a more sustainable transportation system.
4	An Overview of Solar-Powered Electric Vehicle Charging in Vehicular Adhoc Network	<u>Farooque Azam, Neeraj Priyadarshi, Harish Nagar, Sunil Kumar &amp; Akash Kumar Bhoi</u>	As electric vehicles (EVs) become more prevalent, there is a growing need for charging infrastructure. This has led to the incorporation of renewable energy sources to supplement the grid. To further enhance the efficiency and safety of EVs, Intelligent Transportation Systems (ITS) have been developed to provide connected vehicle services. However, designing a charging strategy that optimizes energy utilization is challenging when both EVs and charging stations are considered together in a Vehicular Ad Hoc Network (VANET).

## V. OBJECTIVES

The purpose of this project is to address the challenges faced by electric vehicle owners, such as the need for frequent charging and the reliance on external

electricity sources. By creating an innovative EV charger, this project aims to provide a unique solution that offers several benefits. The wireless charging technology eliminates the need for the vehicle to stop

charging, making it more convenient for the driver. The use of solar energy as a power source makes the charging process more sustainable and eco-friendlier.[1] The coils inserted in the EV charger are designed to prevent wear and tear, ensuring the longevity of the device. Overall, the project aims to provide a more efficient, sustainable, and convenient way of charging electric vehicles, which can contribute to reducing carbon emissions and promoting clean energy.[2]

## VI. METHODOLOGY

Here is a methodology for a research paper based on wireless power transfer using copper coil and solar energy:

In this section, you should introduce the topic of wireless power transfer using copper coil and solar energy. Explain why this technology is important and what potential benefits it could offer. Also, provide some background information on the principles of wireless power transfer and capacitive wireless power transfer. Conduct a comprehensive review of the existing literature on wireless power transfer using copper coil and solar energy. Analyze and compare various approaches and technologies that have been proposed or implemented in this area. Identify any gaps or limitations in the current research, and explain how your proposed methodology can address these issues.[6]

**System design:** In this section, you should describe the design of your proposed wireless power transfer system using copper coil and solar energy. Explain how you plan to implement the capacitive wireless power transfer technology, including the use of two pairs of conductive plates, an inverter, a matching network, and a frequency generator. Provide detailed schematics and diagrams to illustrate the system design.[4]

**Experimental setup:** Describe the experimental setup you will use to test your wireless power transfer system. Explain how you will generate the solar energy required to power the system, and how you will measure the power transfer efficiency and other relevant parameters. Also, describe any safety measures you will take to protect people and equipment from potential hazards.[6]

**Results and analysis:** Present the results of your experiments and analyze them in detail. Calculate the power transfer efficiency and compare it to other similar systems reported in the literature. Identify any factors that affect the efficiency and discuss their implications. Also, discuss any unexpected results or limitations of your system.[2]

Summarize the main findings of our research and explain their significance. Discuss the potential

applications of your wireless power transfer system using copper coil and solar energy, and any future research directions. Finally, provide some recommendations for improving the performance and efficiency of the system.[4]

## VII. SOFTWARE AND HARDWARE FOR DEVELOPMENT

- Arduino
- RECTIFIER
- FILTER
- VOLTAGE REGULATOR
- TRANSISTOR
- LED
- 1N4007
- RESISTOR
- CAPACITOR
- Atmega 328p
- 4047IC
- Coil
- Rectifier
- 16\*2 LCD display

## VIII. SYSTEMARCHITECTURE

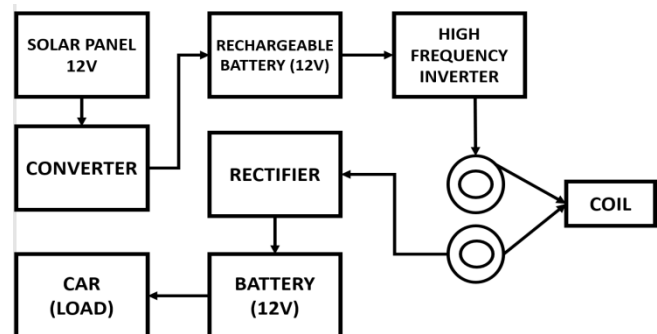

Fig. 1 Architecture

## IX. FRAME DIAGRAM

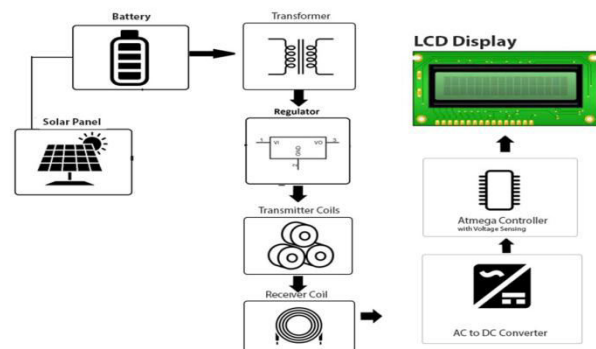

Fig. 2 Frame

VI. BLOCK DIAGRAM

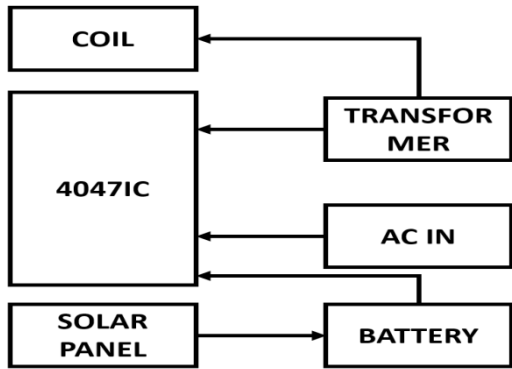

Fig. 3.1 BlockDiagram

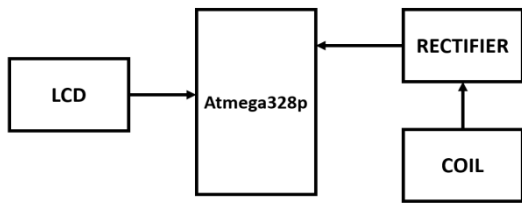

Fig. 3.2 BlockDiagram

X. CIRCUIT DIAGRAM

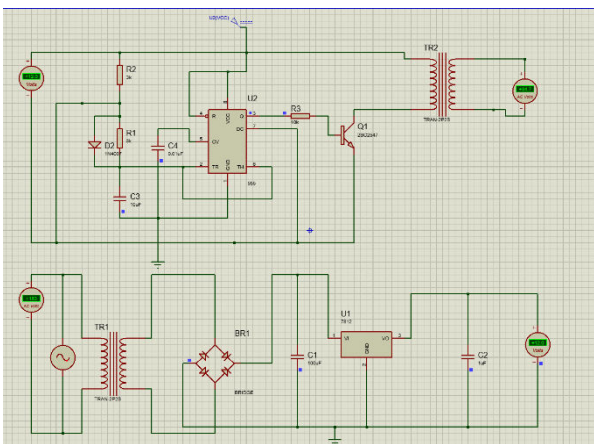

Fig. 4 CircuitDiagram

XI. ADVANTAGES

- The proposed technology aims to revolutionize the way we charge electric vehicles. Instead of stopping to charge the vehicle, the technology allows for wireless charging while the vehicle is in motion. The system is powered by solar energy, eliminating the need for an external power supply.
- The technology involves the integration of coils in the road, which will create a magnetic field that can transfer energy wirelessly to the vehicle's battery as it moves over

the coils. The coils are designed to be durable and able to withstand the wear and tear of constant use.

- One of the benefits of this technology is that it eliminates the need for the vehicle to stop and recharge, allowing for a more seamless and efficient driving experience. The use of solar power also makes the system more sustainable and environmentally friendly.
- Overall, this wireless charging system for electric vehicles has the potential to revolutionize the transportation industry by providing a more convenient and sustainable solution for charging electric vehicles.

XII. RESULT

In this proposed system, power is first converted to AC using a transformer and then controlled using an electronic regulator. Electric current is used to power the copper coil used for wireless transmission. A copper coil is also placed underneath the electric vehicle (EV), which allows for the wireless transmission of power to the vehicle as it is driven over the coil.

The power transferred from the transmission to the electric coil is in the form of DC current. This DC current is converted back to direct current to charge the electric car batteries. This process allows for the seamless wireless charging of electric vehicles while they are in motion, without the need for stopping to recharge.

It is important to note that this technology relies on the use of copper coils for wireless power transmission, which can be costly to produce and may require significant infrastructure investment. However, if successfully implemented, it has the potential to revolutionize the electric vehicle industry and provide a more convenient and efficient way to charge electric vehicles.

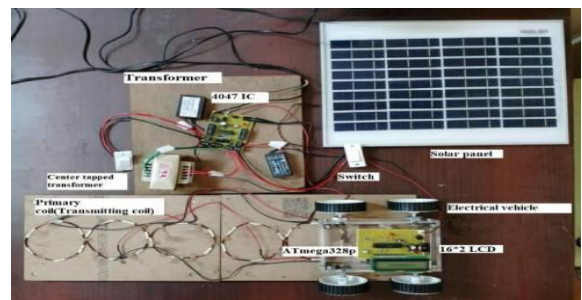

Fig.5.1 Result 1



## XIV. ACKNOWLEDGMENT

We are pleased to present the preliminary project report on the 'Solar Wireless Electric Vehicle Charging System.' We would like to express our gratitude to our internal guide and the Training and Placement Officer (TPO) of our Electronics and Telecommunication (E&TC) Department, Professor

M.K. Bhosale. His constant support and guidance have been invaluable to us throughout this project.

We appreciate his valuable advice, which has helped us to overcome many challenges and provided us with a better understanding of the subject matter. We are grateful for his efforts in guiding us toward the successful completion of the project.

Once again, we would like to extend our sincere thanks to Professor M.K. Bhosale for his contribution and support towards this project.

## REFERENCES

- [1] Kang Miao, Bidirectional battery charger for electric vehicles, Asia (ISGT Asia) 2018.
- [2] Pinto, J. G. Bidirectional battery charger with Grid-to-vehicle, Vehicle-to-Grid and Vehicle-to-Home technologies, IEEE 2020.
- [3] [Bugatha Ram Vara prasad, "Solar Powered BLDC Motor with HCC Fed Water Pumping System for Irrigation," *Int. J. Res. Appl. Sci. Eng. Technol.*, vol. 7, no. 3, pp. 788–796, 2019, doi: 10.22214/ijraset.2019.3137.
- [4] Gallardo-Lozano, Milanes-Monster, GuerreroMartinez, Three-phase bidirectional battery charger for smart electric vehicles, International Conference-Workshop 2021.
- [5] M. C. Kisacikoglu, "Vehicle-to-grid (V2G) reactive power operation analysis of the EV/PHEV bidirectional battery charger," Ph.D. dissertation, University of Tennessee, Knoxville, 2019.
- [6] Bugatha Ram Vara Prasad, K. M. Babu, K. Sreekanth, K. Naveen, and C. V. Kumar, "Minimization of Torque Ripple of Brushless DC Motor Using HCC with DC-DC Converter," vol. 05, no. 12, pp. 110–117, 2018.
- [7] W. Green and J. T. Boys, "10KHz inductively coupled power transfer-concept and control," in *roc. 5th Int. Conf. Power Electron. Variable-Speed Drives*, Oct. 2019, pp.694-699.

# Comparative Analysis of Model Order Reduction Techniques for Higher Order System

Yousef Hussein Mohammed Alqardai  
*Electrical Electronics and  
 Communication Engineering*  
 Sharda University,  
 Greater Noida, India  
 2021812433.yousef@pg.sharda.ac.in

Suman Lata  
*Electrical Electronics and  
 Communication Engineering*  
 Sharda University,  
 Greater Noida, India  
 suman.lata@sharda.ac.in

TarunVarshney  
*Electrical Electronics and  
 Communication Engineering*  
 ShardaUniversity,  
 Greater Noida, India  
 tarun.varshney@sharda.ac.in

**Abstract**— There are several challenges in modelling real - time systems. Accurate modelling of a big real-time system is complicated. Huge numbers of differential or difference equations are developed during the modelling of complex real-time systems, and from these equations higher order systems are illustrated using state space or transfer function concepts. It is difficult to handle the designing as well as the analysis of the higher order system model. To resolve these issues reduction of the system using time and frequency domains methodologies have been described in this paper. Model order reduction mandates that the produced lower order model must maintain crucial and critical qualitative and quantitative qualities including stability, the original system's transient and steady state response. Two such approaches, namely, aggregation method and modal analysis approach have been compared after applying these to an assumed 4<sup>th</sup> order system on the basis of their time domain specifications. All the simulations have been done in MATLAB. It has been concluded by the authors that the time domain specifications obtained from analyzing step response for the both the aggregation as well as modal analysis approaches of the reduced order system are approximately equivalent to those of higher order system. Modal analysis approach the errors in peak amplitude is 0.2005%, settling time is -0.51%, and for final value is 0.2005%. All these errors are within acceptable ranges and thus it proves to be a better modal reduction technique over aggregation method.

**Keywords**— LTI, order, state space representation, time domain specifications.

## I. INTRODUCTION

There are several scenarios that pose challenges for efficient numerical simulation in science and engineering. These include problems with high dimensions, nonlinearity, multi-scale complexities, complex geometries, uncertainty quantification, and real-time requirements. These scenarios can make simulations computationally expensive or difficult to perform accurately using traditional numerical methods [1].

This research work presents a review of model order reduction techniques and a comparison of time domain techniques, namely, aggregation method and Model analysis approach for an assumed system.

Model order reduction (MOR) is a common approach in which the higher dimensional system is mapped with lower dimensional subspace [2]. However, it is crucial to make sure that the reduction process is both reliable and effective in terms of computing [3].

The existence of large-scale systems can be found everywhere and in a variety of contexts, including complex chemical

reactions, ecological, aeronautics, mechanical, and environment systems, among others, or a combination of these. A system is called complex if, for computational or practical reasons, it may be divided into a number of smaller, connected systems. Similarly, for a big system the dimensions are so large that it is impossible to accurately solve the problem using traditional modelling, analysis, control system design, and computation methods. The first step in analyzing such physical systems is to create a model that can be regarded as an accurate depiction of them. The formulation of a model is the first step for designing, developing and monitoring of control system. With this model, the analysis and design may be completed [4].

A complicated model of high order is originally formed when a system is mathematically simulated for inspection and modification, whether it is already in operation or is still being constructed. Rrepresentations in the time and frequency domains, also known as state space and transfer function forms, respectively, can be used to explain high order nonlinear systems' mathematical concepts [5]. In the state space (time domain) representation of higher order differential equation is separated into a group of 1<sup>st</sup> order differential equations. In time domain representation the higher order differential equation under zero initial parameters is used to represent the mathematical model of the system. However, frequency domain, the Laplace transform (system Transfer function) , which is a ratio of two function is used to represent the mathematical model of a system [6].

It is challenging to analyze, synthesize, and identify the system characteristics if the order of the given system is high. Time-constant, damping ratio, natural frequency, from the higher order system (HOS) using order reduction model is used to simulate system performance [7].

## II. NEED OF MOR

Many engineering problems need the approximation of linear systems, particularly in the designing of control systems, where a developer must control the physical system whose mathematical modelis represented by a high order linear system [4,8].

The major goals of obtaining the lower order model are to clearly understand the system and to simplify the hardware and software, to make feasible design, and to obtain simple control laws [9]. As a result, model order reduction strategies aid in implementation of the system. Main causes for lowering a system's order are:

- To make the system easy to understand.
- To minimize computational complexity while system analysis.
- To synthesize the system with lower hardware cost.

### III. CLASSIFICATION OF MOR

In the area of model reduction, several scholars and researchers have developed a variety of MOR strategies [7,10,11,12]. The two primary categories of model order reduction techniques are (i) time domain order reduction techniques and (ii) frequency domain order reduction techniques. The MOR techniques referred to as time domain order reduction techniques when they are used to decrease the state space model of the system, and frequency domain order reduction approaches when they are used to reduce the transfer function models of the system. Whatever method is used to solve the model order reduction challenges [1,9], the basic targets of model reduction is to lower down the order so as to mimic the important features of the origin system. Classification of MOR

#### A. Time domain MOR approaches

A common goal of methods applied for time domain model order reduction is to match the response time of the reduced order model with that of HOS for the given input. The original and reduced systems are given in state space form in time domain reduction techniques. The output ( $Y$ ) will be a close approximation of ( $Y_r$ ) for the stated inputs because the order of the reduced matrices  $A_r$ ,  $B_r$ , and  $C_r$  is less than order of the original matrices  $A$ ,  $B$ , and  $C$  [13].

A thorough understanding of the general features of system and eigenvalues and eigenvectors are both necessary for the time domain order reduction methodologies.

There are various types of time domain order reduction techniques which have been applied by the researchers in the last decade such as aggregation method, balancing truncation method and modal analysis approach [8,14].

#### B. Frequency domain MOR approaches

A transfer function applicable for reduction of original high order systems provides the basis for several frequency domain order reduction strategies. These methods typically have an obvious appeal and are simple to handle computationally. Majorly there are three methods of this types of reduction techniques, namely, classical reduction method (CRM), stability preservation method (SPM) and stability criterion method (SCM) [15].

### IV. REDUCED ORDER SYSTEM ROLES IN LARGE ENGINEERING SYSTEMS

In the past few years, system engineers have to deal with challenging huge engineering system. These systems are characterized by their high orders, which can reach 500 or even 1000. Even today's fastest computers are unable to handle such massive systems. When dealing with such large systems, model reduction plays an important role [9,16]. As a result, over the past ten years or so, this issue has received a lot of attention. Following are some advantages of using reduced-order models in the analysis of complex engineering systems:

- Simplifying the simulation of a (HOS) in order to gain more insight into its dynamics.
- Creating a substandard controller to reduce the computational work required to acquire an optimal one.
- Acquiring a lower dimension control law to make the feedback controller's structure simpler.

System engineers anticipate that one of their key areas of interest over the next few decades will be the theory of big engineering systems. As a result, reduced-order models will keep being very important in the research and development of such systems.

### V. LITERATURE SURVEY

The basic steps of engineering include modelling and simulation of structures. Analytically or numerically, the system is transformed into an ordinary differential equation (ODE), and then it is resolved using a variety of algorithms. The usual method for solving ODEs with high derivative orders is to convert them into first derivative order matrix equations. The issues is ultimately reduced to an equation using a massive first-derivative matrix, despite the fact that the size of the matrix increases in direct proportion to the number of factors and the order of the derivative products. not the number of derivatives, but the matrix dimension, becomes the primary issue to be solved after this transformation [17]. In Model Order Reduction (MOR), "order" therefore refers to the dimensions of the matrix rather than the order of derivatives. If in case order of the model is high then the structure or system becomes more complicated. As a result, decreasing the order of the modelled system is a sensible and practically suggested to increase the computational effectiveness of the analysis. Essential concepts and principles that are applied in MOR can be developed by examining eigenproblems. Reduced order models make the process of designing a controller relatively simple, that is why MOR is employed in the field of control engineering [18].

In summary, the complexity of the controller raise while the complexity of the system raise as well, and designing a high-order controller is difficult due to the large number of poles and zeros that may compromise the stability of the system. it is impossible to physically construct controllers of extremely high order. Systems with a small order around 100 also require MOR since contemporary control techniques like the linear quadratic regulator (LQR) produce controllers with the same order as the system itself. Hence, to develop a durable and physically practical controller, the system's order must be reduced [19]. The demand for MOR also results from structural analysis, particularly since that finite element (FE) analysis is so prevalent. The FE method's fundamental idea is to approximate a continuous physical structure using the sum of discretized elements. Due to its division into small parts, the approximated modeling resembles the actual structure more closely. A complex enormous structure should be split into smaller elements utilizing FE analysis to improve the accuracy of mathematical modeling. As a result, the model is quite complex, with several hundred thousand degrees of freedom, for example. In structural analysis, optimization, and controller design, complex model increases computing time and effort, Model reduction strategies are researched and employed in various areas of engineering and mathematics based on the

aforementioned needs [20,21]. However effectively they serve each of its respective purposes, there are still challenges like parametric MOR.

## VI. MATHEMATICAL MODELLING OF MOR

Variety of mathematical modeling methods have been proposed by researchers in the area of MOR [10,13].

The following time domain order reduction techniques, which have been applied in current research work, are briefly described in this section.

### A. Aggregation Method

Aggregation is considered as most crucial methods for modelling complex systems and it was firstly proposed by Aoki [22].

It most significant techniques for reduced-order models. This method in the lower order model preserves the significant original system eigenvalues. The fundamental advantage is that the simplified model preserves a few internal features of the original system that are useful for analysis and identifying state-feedback suboptimal control.

Consider a standard realization of a Linear Time Invariant (LTI) system as given below in equation (1):

$$\begin{aligned} \dot{x}(t) &= Ax(t) + Bu(t) \\ y(t) &= Cx(t) + Du(t) \end{aligned} \quad (1)$$

The model matrix M for the higher order system is given by equation (2),

$$M = \begin{bmatrix} M_1 & M_2 \\ M_3 & M_4 \end{bmatrix} \quad (2)$$

Where  $M_1$  and  $M_4$  has dimensions  $(m * m)$  and  $(n - m) \times (n - m)$  respectively.

The inverse of the model matrix (N) of the HOS is given

by equation (3)

$$N = \begin{bmatrix} N_1 & N_2 \\ N_3 & N_4 \end{bmatrix} \quad (3)$$

Regular arbitrary matrix ( $R_0$ ) is computed and given by equation (4):

$$R_0 = [I_r \quad ; 0_{r \times (n-r)}] \quad (4)$$

Aggregation matrix (F) is given below in equation (5):

$$F = M_1 R_0 N \quad (5)$$

Reduced order state space realization ( $A_r, B_r, C_r, D_r$ )

can be evaluated by equation (6):

$$\begin{aligned} A_r &= K A F^T [F F^T]^{-1} \\ B_r &= F B \\ C_r &= C F^T [F F^T]^{-1} \end{aligned} \quad (6)$$

Reduced order state space realization ( $A_r, B_r, C_r, D_r$ )

can be evaluated using equation (7):

$$\begin{aligned} \dot{x}_r(t) &= A_r x_r(t) + B_r u(t) \text{ and,} \\ y_r(t) &= C_r x_r(t). \end{aligned} \quad (7)$$

### B. Modal Analysis Approach

This approach aims to preserve the most significant of the original system eigenvalues while obtaining the all parameters of a lower order model. The objective is to ensure that the response time of system with lower order precisely approximates that of the high-order system, for a specific input.

Essentially, the method discards the influence of distant poles and zeros, focusing only on the dominant ones. This method has been proposed firstly in 1966 by Divison [23].

In order to understand the algorithm for this method, Consider The standard realization of LTI system as given by equation (1). Where,  $x \in \mathbb{R}^n, u \in \mathbb{R}^m, y \in \mathbb{R}^r$  represent the states, inputs and outputs of the system, respectively.

Find the eigenvalues for the higher order system.

Model matrix (M) for the given higher order model can be found using equation (2) and inverse model matrix (N) is given by equation (8):

$$N = \begin{bmatrix} N_1 & N_2 \\ N_3 & N_4 \end{bmatrix} \quad (8)$$

Sub matrices ( $A_1, A_2, A_3,$  and  $A_4$ ) for given HOS matrix

(A) are described below in equation (9):

$$A = \begin{bmatrix} A_1 & A_2 \\ A_3 & A_4 \end{bmatrix} \quad (9)$$

Sub matrices ( $B_1, B_2$ ) for given higher order input matrix (B) are given by equation (10)

$$B = \begin{bmatrix} B_1 \\ B_2 \end{bmatrix} \quad (10)$$

Reduced order input matrix ( $B_r$ ) is given by equation (11):

$$B_r = B_1 \quad (11)$$

Sub matrices ( $C_1, C_2$ ) for the given higher order output matrix (C) are given by equation (12):

$$C = [C_1 \quad C_2] \quad (12)$$

Reduced order output matrix ( $C_r$ ) can be computed using equation (13):

$$C_r = C_1 \quad (13)$$

Reduced order state space realization ( $A_r, B_r, C_r, D_r$ ) computed using equation (14):

$$\begin{aligned} \dot{x}_r(t) &= A_r x_r(t) + B_r u(t) \text{ and,} \\ y_r(t) &= C_r x_r(t). \end{aligned} \quad (14)$$

## VII. A CASE STUDY

Time MOR techniques described in section 4 have been applied to a 4<sup>th</sup> order system. The step response properties of the reduced order system and original system have been calculated and compared. For the same MATLAB Version 2023 a has been used.

### A. Aggregation Method

For the considered system the (A, B, C, D) state space realization is represented by equations numbered as (15).

$$x(t) = \begin{bmatrix} -2 & -2 & 12 & -4 \\ 0 & -4 & 4 & 0 \\ 0 & 0 & -6 & 2 \\ 0 & 0 & 0 & -8 \end{bmatrix} x(t) + \begin{bmatrix} 1 \\ 1 \\ 1 \\ 1 \end{bmatrix} u(t) \quad (15)$$

$$y(t) = [1 \quad 1 \quad 1 \quad 1] x(t)$$

The algorithm of aggregation method presented in section (4.1) has been applied to the assumed system. The state space realization ( $A_r, B_r, C_r, D_r$ ) of reduced 2<sup>nd</sup> order system have been computed and is given below in equation (16).

$$x_r(t) = \begin{bmatrix} -2 & -2 \\ 0 & -4 \end{bmatrix} x_r(t) + \begin{bmatrix} 2 \\ -2.986 \end{bmatrix} u(t)$$

$$y_r(y) = [1.143 \quad 0.246] x_r(t) \quad (16)$$

Step response of the original (4<sup>th</sup> order) and reduced order (2<sup>nd</sup> order) are as presented in figure (1).

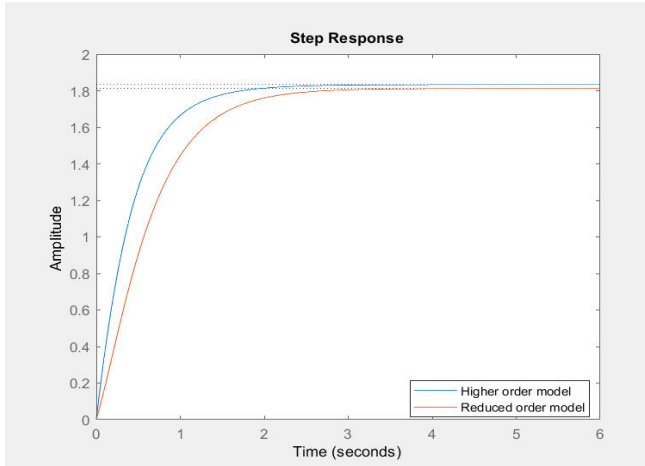

Figure (1): Step response

For comparison various step response parameters (time domain specification) of HOS and reduction order model are given in table (1). Also the error % in each parameter are calculated.

Table (1): Step response specifications

Step response parameter	Higher order system	Reduced order system	Error %
Peak Amplitude	1.83 %	1.81 %	-1.093
Settling Time (sec)	1.96	2.18	11.225
Rise Time (sec)	0.915	1.26	37.705
Peak Time (sec)	6	6	0
Final value	1.83	1.81	-1.093

**B. Modal analysis approach**

For the considered 4<sup>th</sup> order model modal analysis approach has been applied and (A, B, C, D) as state space realization given by following set of equation for a system as described by equation (17).

$$x(t) = \begin{bmatrix} -2 & -2 & 12 & -4 \\ 0 & -4 & 4 & 0 \end{bmatrix} x(t) + \begin{bmatrix} 1 \\ 0 \end{bmatrix} u(t) \quad (17)$$

$$y(t) = [1 \quad 1 \quad 0 \quad 0] x(t)$$

The algorithm of modal analysis approach presented in section (4.2) has been applied to the assumed system. After applying it to the higher order system the state space realization (A<sub>r</sub>, B<sub>r</sub>, C<sub>r</sub>, D<sub>r</sub>) of reduced 2<sup>nd</sup> order have been computed and is represented by equation (18). References

$$x_r(t) = \begin{bmatrix} -2 & -2 \\ 0 & -4 \end{bmatrix} x_r(t) + \begin{bmatrix} 1 \\ 0 \end{bmatrix} u(t) \quad (18)$$

$$y_r = [1 \quad 1] x_r(t)$$

Time domain response of both 4<sup>th</sup> and 2<sup>nd</sup> are as shown in figure 2 given below.

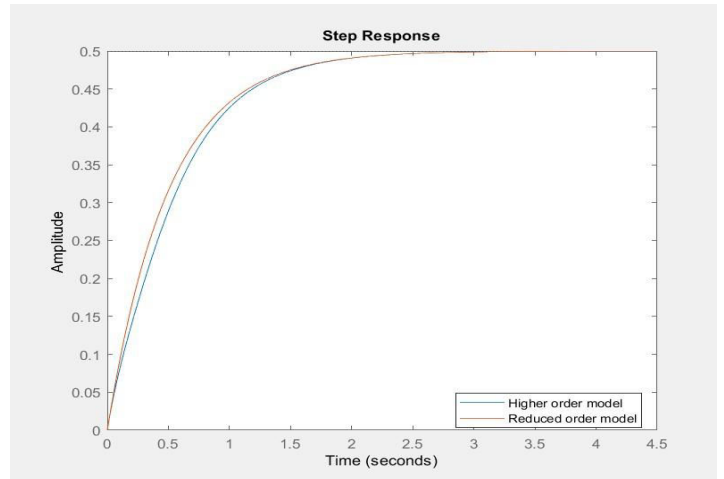

Figure (2): Step response

For comparison various step response parameters (time domain specification) of HOS and reduction order model are given in table (2). Also, the error % in each parameter are calculated.

Table (2): Step response specifications

Step response parameter	Higher order system	Reduced order system	Error %
Peak Amplitude	0.499 %	0.5 %	0.2005
Settling Time (sec)	1.97	1.96	-0.51
Rise Time (sec)	1.13	1.13	0
Peak Time (sec)	4.5	4.5	0
Final value	0.499	0.5	0.2005

**VIII. CONCLUSIONS**

The settling time, rise time, peak time and final value obtained from the step response have been computed for both the assumed 4<sup>th</sup> order and reduced order systems while applying two approaches for model order reduction, namely, aggregation method and modal analysis approach. In both model order reduction techniques, reduced second order models are observed to be approximately equivalent to those of higher order systems. In case of aggregation method, the percentage error in the rise time is as high as 37.705%. The % error in peak amplitude is -1.093%, settling time is 11.225%, and for final value is -1.093%. However, modal analysis approach has been a better technique with rise time is as high as 0%. The % error in peak amplitude is 0.2005%, settling time is -0.51%, and for final value is 0.2005%. Consequently, modal analysis approach proves to be a better technique of model order reduction. By minimizing computational costs, these techniques enable faster and more efficient simulations. Which can lead to significant advancements in various fields.

**IX. REFERENCES**

[1] G. Obinata and B. D. O. Anderson, Model reduction for control system design. Springer Science & Business Media, 2012.

- [2] Z. Bai and Y. Su, "Dimension reduction of large-scale second-order dynamical systems via a second-order Arnoldi method," *SIAM J. Sci. Comput.*, vol. 26, no. 5, pp. 1692–1709, 2005.
- [3] M. Verlaan, *Efficient Kalman filtering algorithms for hydrodynamic models*. Technische Universiteit Delft, 1998.
- [4] A. Gruca and P. Bertrand, "Approximation of high-order systems by low-order models with delays," *Int. J. Control*, vol. 28, no. 6, pp. 953–965, 1978.
- [5] D. Teegarden, G. Lorenz, and R. Neuf, "How to model and simulate microgyroscope systems," *Ieee Spectr.*, vol. 35, no. 7, pp. 66–75, 1998.
- [6] P. Benner, "Solving large-scale control problems," *IEEE Control Syst. Mag.*, vol. 24, no. 1, pp. 44–59, 2004.
- [7] A. Bultheel and M. Van Barel, "Padé techniques for model reduction in linear system theory: a survey," *J. Comput. Appl. Math.*, vol. 14, no. 3, pp. 401–438, 1986.
- [8] Z. Elrazaz and N. K. Sinha, "A review of some model reduction techniques," *Can. Electr. Eng. J.*, vol. 6, no. 1, pp. 34–40, 1981.
- [9] G. Parmar, R. Prasad, and S. Mukherjee, "A mixed method for large-scale systems modelling using eigen spectrum analysis and cauer second form," *IETE J. Res.*, vol. 53, no. 2, pp. 93–102, 2007.
- [10] B. D. O. Anderson and Y. Liu, "Controller reduction: concepts and approaches," in *1987 American Control Conference*, 1987, pp. 1–9.
- [11] D. Chaniotis and M. A. Pai, "Model reduction in power systems using Krylov subspace methods," *IEEE Trans. Power Syst.*, vol. 20, no. 2, pp. 888–894, 2005.
- [12] K. Carlberg, D. Amsallem, P. Avery, M. Zahr, and C. Farhat, "The GNAT nonlinear model reduction method and its application to fluid dynamics problems," in *6th AIAA Theoretical Fluid Mechanics Conference*, 2011, p. 3112.
- [13] L. Fortuna, G. Nunnari, and A. Gallo, *Model order reduction techniques with applications in electrical engineering*. Springer Science & Business Media, 2012.
- [14] C.-F. Chen, "Model reduction of multivariable control systems by means of matrix continued fractions," *Int. J. Control*, vol. 20, no. 2, pp. 225–238, 1974.
- [15] R. Genesio and M. Milanese, "A note on the derivation and use of reduced-order models," *IEEE Trans. Automat. Contr.*, vol. 21, no. 1, pp. 118–122, 1976.
- [16] J. E. Bracken, D.-K. Sun, and Z. Cendes, "Characterization of electromagnetic devices via reduced-order models," *Comput. Methods Appl. Mech. Eng.*, vol. 169, no. 3–4, pp. 311–330, 1999.
- [17] H. Panzer, J. Mohring, R. Eid, and B. Lohmann, "Parametric model order reduction by matrix interpolation," 2010.
- [18] M. Hutton and B. Friedland, "Routh approximations for reducing order of linear, time-invariant systems," *IEEE Trans. Automat. Contr.*, vol. 20, no. 3, pp. 329–337, 1975.
- [19] B. Bandyopadhyay, O. Ismail, and R. Gorez, "Routh-Pade approximation for interval systems," *IEEE Trans. Automat. Contr.*, vol. 39, no. 12, pp. 2454–2456, 1994.
- [20] K. Ogata, *Modern control engineering*, vol. 5. Prentice hall Upper Saddle River, NJ, 2010.
- [21] B. Bond and L. Daniel, "Parameterized model order reduction of nonlinear dynamical systems," in *ICCAD-2005. IEEE/ACM International Conference on Computer-Aided Design*, 2005., 2005, pp. 487–494.
- [22] M. Avoki, "Control of large dynamic system by aggregation," *IEEE Trans. Autom. Control*, vol. 13, pp. 246–256, 1968.
- [23] E. Davison, "A new method for simplifying large linear dynamic systems," *IEEE Trans. Automat. Contr.*, vol. 13, no. 2, pp. 214–215, 1968.

# Identification of Duplicate Bug in Bug Triaging System

1<sup>st</sup> Tanisha Dixit

MCA 1<sup>st</sup> Year Student

Institute of Technology & Science

Mohan Nagar, Ghaziabad, India

tanishadixit\_mca22\_24@its.edu.in

2<sup>nd</sup> Prajwal Pandey

MCA 1<sup>st</sup> Year Student

Institute of Technology & Science

Mohan Nagar, Ghaziabad, India

prajwalpandey\_mca22\_24@its.edu.in

3<sup>rd</sup> Saurabh Saxena

Assistant Professor

Institute of Technology & Science

Mohan Nagar, Ghaziabad, India

coord.mca@its.edu.in

**Abstract**—With the arrival of the Internet and the spread of computer freaks, multiple operations have been developed that are used by millions of user's everyday tasks like office operations or web surfers. Software companies spend over 45% of their costs dealing with software bugs. An unavoidable step of fixing bugs is bug triage which aims to properly assign a developer to a new bug. Bug-shadowing and issue-tracking systems tend to be populated with bugs, issues, or tickets written by a wide variety of bug journalists with different situations of training and knowledge about the system being bandied about. Numerous bug journalists warrant the expertise, vocabulary, knowledge, or time to efficiently search the issue tracker for comparable issues. Software bugs do for a wide range of reasons. Addressing these bugs for the maturity of trouble spent in the conservation phase of a software design life cycle. Most frequently, several bug reports, transferred by different druggies, match up to the same disfigurement. Nonetheless, every bug report is to be anatomized independently and precisely for the possibility of an implicit bug. The person responsible for recycling the recently reported bugs, checking for duplicates, and passing them to suitable developers to get fixed is called a Triager and this process is called Triaging. The mileage of bug tracing systems is hindered by a large number of indistinguishable bug reports. In numerous open-source software systems as numerous as one-third of all reports are duplicates. This study presents an overview of the work done to better discover identical bugs that have been conducted on open-source data sets.

**Keywords**—*Duplicate Bug Reports, Bug Triage, Bug Triaging System, Duplicate Bugs*

## I. INTRODUCTION

The use of computers in almost every field to make our work easier has led to a large number of software developments for almost every problem statement out there in the real world and this process will continue in the future. Talking about Software bugs, a Bug can be defined as an error, mistake, or fault that may be a cause of failure during execution or results may deviate from the expected results.

There can be a lot of reasons for the occurrence of bugs which can be corner cases, technical issues, non-functional qualities, or misunderstanding of problems by developers, etc. [1,2].

**A. Bug Triage**—Bug triaging is a critical process in software development that involves identifying and prioritizing bugs reported by users or testers. However, the increasing number of bug reports and the involvement of multiple stakeholders in the bug-triaging process can make it a time-consuming and challenging task. One of the major challenges in bug triaging is identifying duplicate bugs, i.e., bugs that have been reported multiple times by different users. This research paper focuses on the identification of duplicate bugs in bug-triaging systems and proposes an approach that can improve the efficiency and effectiveness of bug-triaging.

**B. Bug Triaging Systems**—Feting bugs as a “ fact of life ”, numerous software systems give methodologies for users to report bugs and to store these bug/issue reports in a bug-shamus (or issue-shadowing) system. The issue-tracking systems like Bugzilla[3] and Google’s issue-tracker [4] enable

the users and testers to report their findings in a unified setting. These systems enable the correspondents to specify a

the report belongs to, the product the report is about, etc.

for the bug reports, similar to the type of the bug report (fault or specific request), the element in the system also, the developers will choose the reported bugs considering some of their features. The tagged bug reports are handled with respect to their precedence and finally closed. The issue-tracking systems also give users the establishment to track the status of bug reports.

**C. Bug Report**—A bug report is a specific report that outlines information about what's wrong and needs fixing with software or on a website. The report lists reasons, or seen misdoings, to point out exactly what's viewed as wrong, and also includes a request and/ or details for how to address each issue.

Relating indistinguishable bug reports is of great significance since it can save time and trouble for

set of features

developers. lately, numerous experimenters like Bettenburg et al. [5]. have concentrated on this problem. They are some of the important encouragements for detecting the same bug reports

- Duplicate bug reports may be assigned to different developers by mistake which results in wasting developers' time and work.
- Eventually, relating the same bug reports can also be helpful in fixing the bugs, since some of the bug reports may give further useful descriptions than their duplicates[5].

**Bugzilla@Mozilla - Bug 424962** Firefox 2 fails to render decomposed unicode umlauts correctly

Home | New | Search | Find | Reports | Requests | New Account | Help | Log In

Bug List: (This bug is not in your last search results) Show last search results

**Bug 424962 - Firefox 2 fails to render decomposed unicode umlauts correctly**

**Status:** UNCONFIRMED **Reported:** 2008-03-25 03:55 PDT by [Leho Kraav](#)  
**Modified:** 2008-03-25 04:02 PDT ([History](#))

**Product:** Firefox  
**Component:** General  
**Version:** 2.0 Branch  
**Platform:** Macintosh Mac OS X

**Importance:** -- normal with 1 vote (vote)  
**Target Milestone:** ---  
**Assigned To:** Nobody: OK to take it and work on it  
**QA Contact:** [general@firefox.bugs](mailto:general@firefox.bugs)

**URL:**  
**Whiteboard:**  
**Keywords:**

Fig. 1.3.1: Sample Bug Report of Mozilla - Bug 424962[16]

#### D.

#### Bug

#### Life

#### Cycle

A recently submitted bug report has the status of either NEW or UNCONFIRMED. When the report is assigned to the required developer, the status is changed from NEW to ASSIGNED. When the report is unrestricted, the status is set to RESOLVED. After the report is vindicated by the quality assurance crew, its status will change to VERIFIED and further CLOSED. There are a limited number of different ways for resolving a bug report. In Bugzilla, these are called resolutions. If a bug report operated in a change in code, its

resolution will be FIXED. If it's feted as a duplicate of a subsisting report, it'll be resolved as DUPLICATE. However, if the bug isn't reproducible. It will be resolved as WORKSFORME. If the report explains a problem that couldn't be fixed, the report will be resolved as WONTFIX. However, it will be resolved as INVALID, if the report wasn't an actual bug.. However, its resolution status, if the report is related to another repository changes to MOVED. A resolved bug report may be opened later with the restarted resolution.

## II. LITERATURE REVIEW

In 2019, Neysiani et al.[9] proposed two models for identifying duplicate bugs. The first model uses machine learning techniques to identify the characteristics of bug report duplication. The second model, known as IR-technique or Informational Retrieval Technique which is getting the required information from a variety of information sources, ranks the top k bug reports. Nguyen et al.[6] offered a duplicate bug report detection system that uses subject modeling and information retrieval (2012). To capture the problem structure for a bug report, the Latent Dirichlet Allocation (LDA) topic modeling technique is extended. If

two bugs share a common conceptual property, they are referred to as duplicate software bugs. The topic modeling technique and the information retrieval strategies are combined using the ensemble averaging technique. According to the study that has been provided, accuracy has increased by 20%, with an accuracy rate of about 83%–84%.

Tian et al.[7] expand on Jalbert and Weimer's most recent study on report classification. By extending their technique, they used REP, which was recently proposed for the report retrieval problem, to determine how similar two bug reports are to one another..

## III. METHODS

Reference	Methods Used	Data Set	Conclusion
Kucuk et al.[2021]	A thorough understanding of duplicated bugs, various properties of duplicated bugs were divided into Categories 1 (Master-Unresolved) and 2 (Missed Reopen)	Mozilla, and Eclipse	In Eclipse and Mozilla, approximately 16% and 23% of bugs are duplicated.
Rakha et al.[2016] [11]		Firefox, SeaMonkey, Bugzilla, and Eclipse-Platform	<ol style="list-style-type: none"> <li>50% of the duplicate reports are detected.</li> <li>Average recall- 0.23 and 0.93, and precision 0.600 and 0.72.</li> </ol>
Ebrahimi et al.[2019] [12]	Bug stack traces by using Hidden Markov Models(HMM)	GNOME and Firefox	recall levels of 80% and 63% have been attained
Neysiani et al.[2019a] [13]	Textual similarity technique	Eclipse, Firefox, OpenOffice, & Android	accuracy rate of between 89% and 93%

## IV. METHODOLOGY

In this part, we give a description of the methodology we studied and is used by Tuzun et al.[15]

There have been several studies that probe indistinguishable bugs[3,4,5] and restarted bugs independently. Still, to the stylish of our knowledge, there has been no previous work on

understanding the dynamics of their crossroad. In this study, we study the orders of indistinguishable bugs to show that not all duplicates are the same and they've distinguishable characteristics. We study the categorization of indistinguishable bugs according to their creation(reported) time with respect to their master's resolution status. The duplicates that have been submitted before the resolution of their master bugs are appertained to as Master- Unresolved and those that have been submitted after the resolution of their master bugs is pertained to as Master- Resolved(Missed Reopen Bug). The anticipated geste for handling the duplicates of Master- Resolved bugs are continuing the master of the corresponding bug rather than opening a new one. On the other hand, the anticipated actions for the duplicates of Master- Unresolved bugs aren't being opened at all since the master bug is still active. Throughout the study, we will relate to the Master- Unresolved bugs as order 1, and to Master- Resolved(Missed Reopen bugs) as Category 2 interchangeably.

In this study, we will be quantitatively assaying non-duplicated (unique) bugs and indistinguishable bugs(order 1 and order 2) in light of the following exploration questions(RQ)

RQ1 How do order 1 and order 2 bugs differ?

RQ1.1 How do order 1 and order 2 differ in terms of the bug's inflexibility?

RQ1.2 How do order 1 and order 2 differ in terms of the number of druggies involved?

RQ1.3 How do order 1 and order 2 differ in terms of indistinguishable bug surface time?

RQ1.4 How do order 1 and order 2 differ in terms of their time distribution over their life cycle?

**A. Categorizing Duplicate Bugs**—In our study, there are two different orders regarding indistinguishable bug reports.. In this regard, we classify the indistinguishable bugs as follows order 1(Master- Unresolved) Duplicates are submitted when masters aren't resolved yet. These indistinguishable bugs might get created before or after their master bugs are assigned which doesn't affect the order they belong to. Since these order 1 duplicates are submitted when masters aren't resolved yet, we name them Master- Unresolved duplicates. Order 2(Master- Resolved or Missed Reopen) Duplicates are

submitted when masters are resolved. In this regard, these indistinguishable bugs might get created before or after the master bug has been vindicated which doesn't affect the order.

**B. Severity of Different Bug Types**— In this section, we discuss the inflexibility of bugs and how it differs among indistinguishable d between master and unique bugs. The attestation of Eclipse, Bugzilla describes the inflexibility types like Blocker, Critical, Major, Minor and trivial .

In this environment, bugs with inflexibility are more advanced than normal and can be considered as bugs that help the system from working duly. For simplicity, we relate to these bugs(i.e., blocker, critical and major) as severe bugs. We calculate the rate of severe bugs in the master of indistinguishable bugs and compare it with the rate in unique bugs to understand if the inflexibility of a bug affects the bug to be duplicated

**C. Number of users Involved in Different Bug Types**—As in utmost of the bug shadowing tools, in Bugzilla, a Carbon Copy(CC) list is used to add people to a mailing list that notifies them when the bug has an updated. The journalist can add users to the CC list.. The number of druggies should indicate the perceived significance of a bug. Thus, we calculate the average number of unique druggies in the CC list to understand if there's a relationship between the number of druggies involved and a bug being duplicated. We also compare the average number of CC list users in Master- Unresolved duplicate bugs(order 1) and Missed Reopen indistinguishable bugs(order 2).

Duplicate Bug Surface Time( DBST) represents the time difference between the reported time of an indistinguishable bug and the reported time of its master bug.

**D. The Time Distribution pattern for Duplicate Bugs**— Duplicate bugs put redundant outflow on software systems, as the trouble and the cost of managing indistinguishable bugs can be time-consuming. Therefore, with the dimension of time distribution, we dissect where the utmost of the time is spent. A bug might be reassigned further than formerly before it gets to the right inventor who resolves the bug as a duplicate. In this case, we choose the time of the last assignment as Tassign. An indistinguishable bug might get resolved as a duplicate without any assignment.

## U V. CONCLUSION

The exploration of bug report deduplication has substantially concentrated on the IR ways and textual comparison of the bug reports to find the duplicates. In this study, we've taken advantage of software surrounds in addition to the textual and categorical comparison criteria to address the darkness of synonymous software-related words within bug reports written by users, who have different vocabularies. - roughly 16% and 23% of bugs are indistinguishable in Eclipse and Mozilla independently, indicating that the duplicated bugs play a significant part in software systems.

- The difference between the two indistinguishable orders in terms of severity is statistically insignificant. Still, this difference between master bugs and unique bugs is significant because when master bugs are duplicated, they are re-evaluated precisely. On the other hand, the inflexibility of an indistinguishable bug isn't meaningful to the development platoon once they realize it's a duplicate of another one, so it isn't re-evaluated.

## REFERENCES

- [1] T. Nakashima, H. Hisada, M. Oyama, and N. Ishii. Analysis of the Software Bug causes and their preventions. 41(15):1059–1068, 1999.
- [2] M. S. Lam and S. Hangal. Tracking down the software bugs using an Automatic Anomaly Detection(AAD). pages 291–301. ACM, 2002.
- [3] N. Serrano and I. Ciordia. Bugzilla, ITracker, and the other bug trackers. *Software*, IEEE, 22(2):11–13, 2005
- [4] N. Ayewah and W. Pugh. The google findbugs fixit, pages 241–252. ACM, 2010.
- [5] S. Kim. Duplicate bug reports are considered harmful... really? In the *Software Maintenance*, 2008, pages 337–345. IEEE, 2008.
- [6] Nguyen, T.N., Nguyen, A.T., Nguyen, T.T., Lo, D., & Sun, C. (2012). A Duplicate bug report detection with the combination of Information Retrieval(IR) & topic modeling. *Proceedings of 27th IEEE/ACM International Conference on Automated Software Engineering* (pp. 7079). IEEE.
- [7] Yuan Tian<sup>1</sup>, Chengnian Sun<sup>2</sup>, and David Lo<sup>1</sup> <sup>1</sup>School of Information Systems, Singapore Management University <sup>2</sup> School of Computing, National University of Singapore
- [8] Q. Xie, Z. Wen, J. Zhu, C. Gao and Z. Zheng, "Detecting Duplicate Bug Reports with Convolutional Neural Networks," 2018 25th Asia-Pacific Software Engineering Conference (APSEC), Nara, Japan, 2018, pp. 416–425, doi: 10.1109/APSEC.2018.00056.
- [9] Babamir SM, Soleimani Neysiani B(2016) Method of Feature Extraction for Detecting Duplicate Bug Reports in the Software Triage System. in the *International Conference on Information Technology, Communications & Telecommunications (IRICT)*, Tehran, Iran.
- [10] Bettenburg, N., Zimmermann, T., & Kim, S. (2008). Duplicate Bugs Reports are considered harmful... really?. In the *International Conference on Software Maintenance* (pp. 337345). IEEE
- [11] Rakha, Shang, M. S., W., and Hassan, A. E. (2016). Studying needed effort to identify Duplicate Issues. *An Empirical Software Engineering*, 21(5), 19601989.
- [12] Ebrahimi, N., Hamou-Lhadj, A., Trabelsi, A., Islam, M. S., &Khanmohammadi, K. (2019). HMM-based approach for an automatic detection and the classification of duplicate bugs reports. *Information & Software Technology*, 113, 98109
- [13] B.S., Neysiani, S.M., &Babamir (2019a). Improving the performance of the automatic duplicate bug report detection using longest common sequence(LCS): Introduction of new textual features for the textual similarity detection. In 2019 fifth conference on the knowledge-based engineering & innovation (KBEI) (pp. 378383). IEEE.
- [14] Behzad Soleimani Neysiani& Zahra Aminoroaya(2018) - Detecting The Duplicate Bug Reports Techniques in *Medwell Journals*.
- [15] BerfinKucuk&ErayTuzun (2021) Characterized the Duplicate Bugs - An Empirical Analysis. In the *International Conference of Software Analysis*. IEEE.
- [16] [https://www.researchgate.net/figure/A-sample-bug-report\\_fig1\\_280027931](https://www.researchgate.net/figure/A-sample-bug-report_fig1_280027931)

# Arduino Augmented Reality Headset

Harsh Pawar  
Sinhgad Institute Of Technology,  
Lonavala,Pune  
harshpawar747@gmail.com

Salil Bhojankar  
Sinhgad Institute Of Technology,  
Lonavala,Pune  
salilbhojankar71@gmail.com

Namrata Chande  
Sinhgad Institute Of Technology,  
Lonavala,Pune  
namanchande2001@gmail.com

Prof. Prashant Dike  
Sinhgad Institute Of Technology,  
Lonavala,Pune  
pdike.sit@sinhgad.edu

*Abstract— The paper highlights the importance of user experience design in AR headset development and provides insights into how Arduino can be leveraged to create immersive and engaging AR experiences. It explores the different sensors that can be used in AR headsets to track head movements, gestures, and other inputs. The combination of Arduino and augmented reality (AR) technology has led to the development of affordable and customizable AR headsets. This research paper explores the various ways in which Arduino-based AR headsets can be designed, built, and programmed. The paper discusses the different types of AR displays that can be used, such as monocular or binocular displays, and their advantages and limitations. Moreover, the research paper addresses the challenges that arise in the development of AR headsets, such as power management, computing performance, and calibration. It also proposes solutions to these challenges using Arduino-based hardware and software.*

*Finally, the paper examines the potential applications of Arduino-based AR headsets in various fields, including education, entertainment, healthcare, and manufacturing. It presents several case studies to demonstrate how AR headsets can be used to enhance learning, improve productivity, and transform the way we interact with the world around us. Overall, this research paper aims to provide a comprehensive overview of the design, development, and applications of Arduino-based AR headsets.*

**Keywords—**Nano R3, AR, MIT App Inventor

## I. INTRODUCTION

Augmented reality (AR) has become a rapidly growing field, with potential applications in various domains such as education, entertainment, healthcare, and manufacturing [2]. AR technology enables the overlaying of digital content onto the real world, enhancing the user's perception and interaction with the physical environment. However, AR headsets that provide an immersive and interactive experience can be expensive and inaccessible to many people. Arduino, an open-source hardware, and software platform, offers a

cost-effective solution for developing AR headsets that are customizable and accessible to a wider audience [1]. Arduino-based AR headsets enable designers and developers to build their own devices using various components such as sensors, displays, and microcontrollers. This flexibility allows for the creation of AR headsets that can be tailored to specific use cases and user needs [4]. The aim of this research paper is to explore the potential of Arduino-based AR headsets and their applications. The paper will discuss the design, development, and programming of AR headsets using Arduino, and examine the challenges and solutions involved in creating effective AR experiences [3]. It will also explore the various sensors, displays, and other components that can be used in AR headsets, as well as the potential applications of this technology in different fields [2]. The research paper seeks to provide a comprehensive overview of the possibilities and limitations of using Arduino for AR headset development and its impact on the broader AR industry [9].

## II. RELATED WORK

Related work in the field of Arduino-based AR headsets has shown promising results in terms of creating affordable and customizable AR devices [10].

One such study by Boer et al. (2017) developed an AR headset using an Arduino microcontroller, a monocular display, and an accelerometer [12]. The system was used to overlay virtual objects onto

real-world environments and was shown to be effective in providing an immersive AR experience [15].

Another study by El-Bakry et al. (2020) developed an AR headset using an Arduino board, a binocular display, and a camera-based tracking system. The system was used to provide real-time object detection and recognition, enabling users to interact with virtual objects in real-time [5].

Moreover, a study by Karim et al. (2020) developed an AR headset using Arduino and 3D printing technology. The system was used to overlay real-time sensor data onto the user's view, enabling users to monitor environmental conditions in real-time [17].

In addition to these studies, various Arduino-based AR projects have been developed by the open-source community [16]. These include the AR Sandbox project, which uses an Arduino board to control a projector and Kinect sensor to create an interactive sandbox that responds to user gestures.

Overall, related work in the field of Arduino-based AR headsets has demonstrated the feasibility and potential of using Arduino as a cost-effective and customizable platform for creating AR devices [14]. However, more research is needed to explore the full potential of this technology and address the challenges involved in creating effective and immersive AR experiences [6].

Augmented Reality (AR) technology is rapidly advancing and becoming popular in various fields such as education, healthcare, and entertainment [8]. However, the cost and complexity of existing AR headsets limit their accessibility to the general public. Furthermore, most commercial AR headsets are designed to meet specific use cases, limiting their flexibility and customization [9]. The complexity of existing AR headsets also makes it difficult for individuals or organizations to develop custom applications and experiences for their users [6]. Therefore, there is a need for a low-cost and user-friendly AR headset that can be easily built and customized by individuals or organizations.

The objective of this research paper is to design and develop an Arduino-based Augmented Reality headset that is affordable, customizable, and easy to use [13].

To conduct a comprehensive literature review of existing AR headset technologies and their limitations [12]. This includes exploring the current state-of-the-art AR headset technologies, their features, and their limitations in terms of cost, accessibility, and customization [3].

To design and build an Arduino-based AR headset that is low-cost and user-friendly [9]. This involves selecting appropriate hardware components, designing a custom PCB, and developing firmware and software to support AR applications.

Table 1: comparative study

Sr.no.	Methodology	Application/advantages	Drawback	Future scope
[5]	Raspberry Pi, OpenCV	Communication aid for deaf and dumb individuals	Limited use case	Improved communication techniques
[6]	Arduino, OpenCV, Fisherfaces	Emotion recognition for individuals with autism spectrum disorders	Limited to facial emotion recognition	Expanding to full body emotion recognition
[10]	Arduino, Vuforia, Unity3D	Maintenance instructions display for industrial applications	Limited to maintenance applications	Expanding to healthcare and education
[13]	Arduino, Eye-tracking sensors, text-to-speech converter	Device control aid for individuals with disabilities	Limited eye-tracking accuracy	Integration with machine learning algorithms
[19]	Arduino ultrasonic sensors	Navigation and rearing aid for visually impaired individuals	Limited obstacle detection accuracy	Integration with machine learning algorithms

III. PROPOSED WORK

The smart glass component works with the consideration principle and the light-focusing principle. The information exhibited on the OLED screen is returned by the mirror and exhibited on the anti-reflective glass and then attentive on the screen by the mirror. The component is powered by a rechargeable 370 mA Li-Polymer battery. With the help of a USB charging circuit, Arduino Nano's power is controlled by the switch. The Bluetooth HC-05 module is controlled by Arduino Nano to show the received output on the OLED screen.

An Arduino Microcontroller has an ATmega328p microprocessor, which is ordered to connect with Smartphones through a Smartphone application. A Rechargeable battery of 5V is used as the power supply for Smart Glass. An OLED display is merged with ATmega328p, which is used to exhibit the data received from Smartphones. Smart-Phone applications are used to transmit data of the phone, i.e., Date, Time, Notifications of the Phone call and Text messages.

These are the main steps that are designed during the whole process:

1. Execution
2. Encoding.
3. Decode and Process.
4. Transmitting and receiving.
5. Notification Received

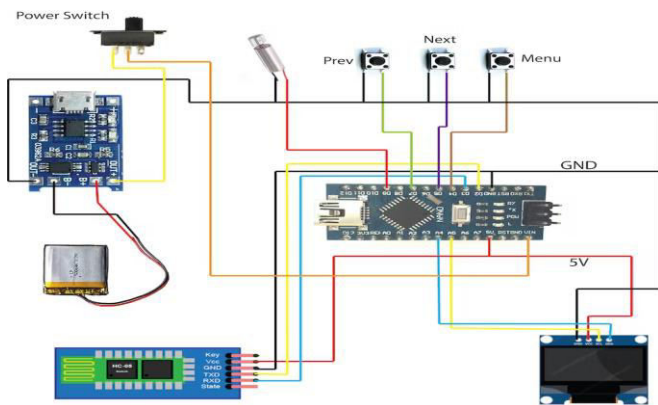

Fig.1. System Architecture

The above circuit will interchange with the application through the Bluetooth module

1. It should receive notifications on the smartphone.

2. This notification should be encoded via the mobile application to be sent via the Bluetooth client.
3. The encoded signal data should be received by the Bluetooth module HC05 and proceed onto the Arduino Nano for decoding and forwarding.
4. The Arduino should forward the signal to the display unit and will receive an optimum output.

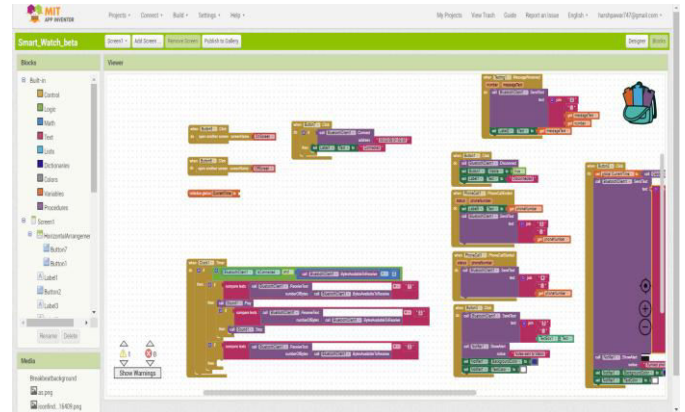

Fig.2 App Build using MIT App Inventor (Output1)

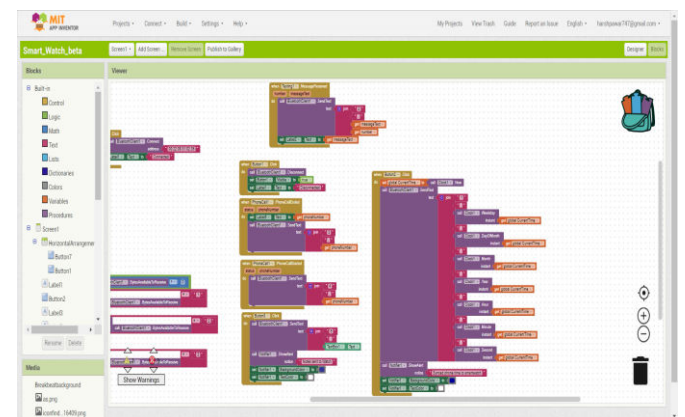

Fig.3 App Build using MIT App Inventor (Output2)

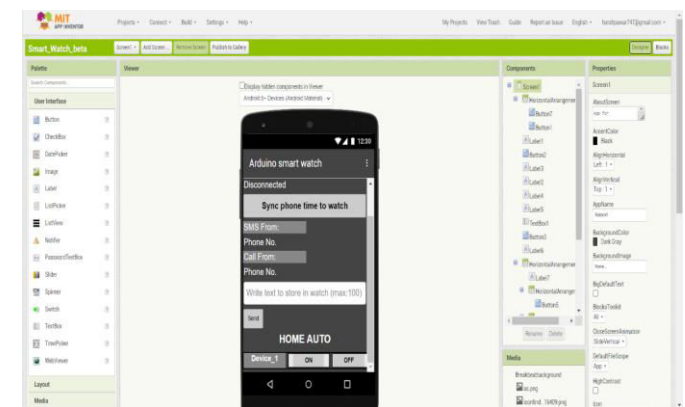

Fig.4 App Build using MIT App Inventor (Output3)

Massachusetts Institute of Technology App Inventor is a web application unified development environment originally maintained by Google and now carried by the Massachusetts Institute of Technology (MIT). It allows strangers to computer programming to design application software apps for two Android operating systems, Android, and iOS. It uses a graphical user interface (GUI) very alike to the programming languages Scratch programming language and Star Logo, which grant users to punch up visual components to make an application that could run on mobile devices. In designing App Inventor, work ready within Google on online development environments, Google extract upon significant primary research in educational computing. Overall, our system should work with the Bluetooth module to access the notifications of a smartphone to appear on the screen.

Thus, in order to work on construction an Android application was the first concern, overall, different modules and network buttons was to be obtained and placed properly. Definite blocks in the app inventor that interchange with the Bluetooth client are evaluated and assembled according to the requirements to pass on the notifications of the smartphone to the display unit join to the spectacles. The App Inventor programs relate how the phone should acknowledge certain events: a button dated pressed, the phone is actually vibrating, or the user is dragging his finger over a canvas.

#### IV.RESULTS AND CONCLUSION



Fig.5 Showing date and time

As the system supplies basic notifications which are examined through the smartphone connected via Bluetooth HC05.

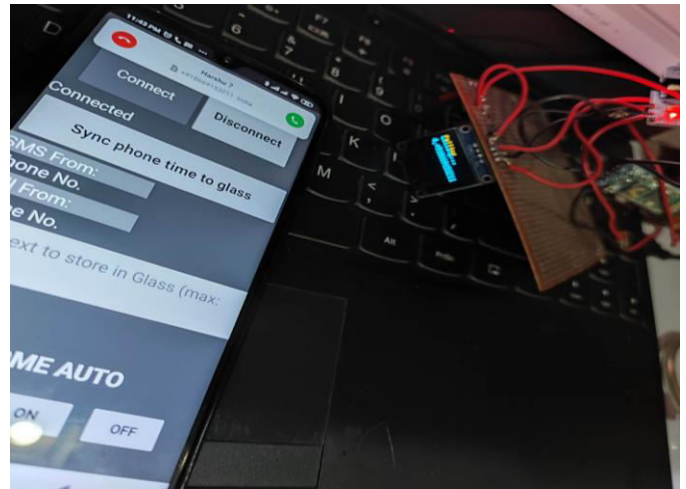

Fig.6 Showing call received

The call is built from an unknown device to the system phone and its returns by appearing the call coming to it with the phone number.

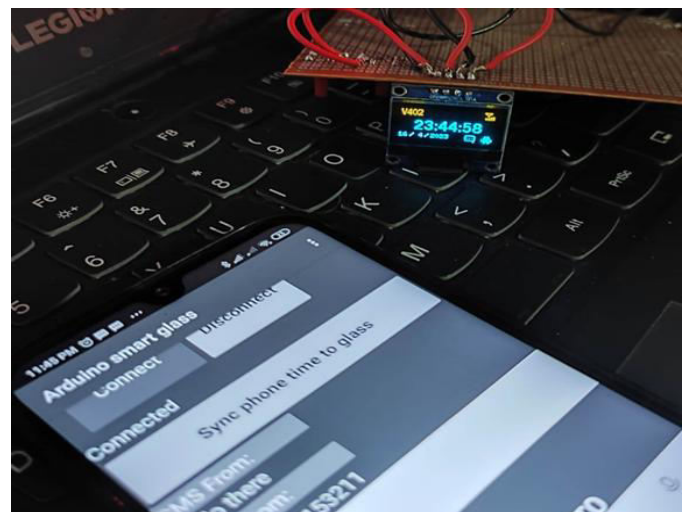

Fig.6 Showing text notification

Here the message collected by phone is shown in the form of notifications with a message icon in the corner.

The paper demonstrates how to build a smart spectacle with basic features. Basic features like times, dates, and notifications in different scenarios. This architecture is designed to be cost-effective and it is very environmentally friendly. As this is the first prototype of our design, with utmost

probability in future we are going to wear these glasses. The prototype just contains the basic feature of notifications such as time and date, messages, and calls. The next version can include advanced features like checking the humidity of the surroundings, temperature, and many others. Audio assistance, smart speakers and voice control functions can be included in advanced versions. A camera can be added to smart spectacles for facial recognition. As it develops for face recognition, we can push the limitation further by including a 360° view. Using Machine learning and Artificial Intelligence these glasses can be used for reading texts which will be beneficial for blind people. Improvisation can be done at an advanced level; a virtual reality environment can be provided. Also, smart glasses have vast scope in Augmented Reality. As technology advances navigation options along with audio options can be added.

#### V. REFERENCES

- [1] Brian L. Due -The future of smart glasses: An essay about challenges and possibilities with smart glasses 2014
- [2] C. Brecher, C. Ecker, W. Herfs, M. Obdenbusch, S. Jeschke, M. Hoffmann and T. Meisen, "The Need of Dynamic and Adaptive Data Models for Cyber-Physical Production Systems," in *Cyber-Physical Systems: Foundations, Principles and Applications*, pp. 321-338, ImpressumWaltham, Elsevier, 2017. ISBN978-0-12-803801-7
- [3] X. Wang, S. Ong and A. Nee, "A comprehensive survey of augmented reality assembly research," *Advances in Manufacturing*, vol. 4, no. 1, pp. 1-22, 2016.
- [4] Tractica (2017) Smart Augmented Reality Glasses <https://www.tractica.com/research/smart-augmented-reality-glasses/> Accessed 2017-02-02.
- [5] G. Kipper, G. and J. Rampolla, *Augmented Reality: An Emerging Technologies Guide to AR*, 1st ed. Boston, MA: Syngress/Elsevier, 2012. ISBN 9781597497343.
- [6] V. Paelke, "Augmented reality in the smart factory: Supporting workers in an industry 4.0 environment," in *Proc. of the 2014 IEEE Emerging Technology and Factory Automation*, 2014, pp. 1-4.
- [7] W. Barfield, *Fundamentals of Wearable Computers and Augmented Reality*, 2nd ed. Florida: CRC Press, 2015. ISBN 97814822435
- [8] J. Li, L. Deng, Y. Gong and R. Haeb-Umbach, "An Overview of NoiseRobust Automatic Speech Recognition," *IEEE/ACM Transactions on Audio, Speech, and Language Processing*, vol. 22, no. 4, pp. 745-777, 2014.
- [9] D. Gorecky, M. Schmitt, M. Loskyll and D. Zühlke, "Human-machineinteraction in the industry 4.0 era," in *Proc. of 12th IEEE International Conference on Industrial Informatics*, 2014, pp. 289-294.
- [10] R. Azuma, Y. Baillet, R. Behringer, S. Feiner, S. Julier and B. MacIntyre, "Recent Advances in Augmented Reality," *IEEE Computer Graphics and Applications*, vol. 21, no. 6, p. 34-47, 2001.
- [11] D. Gough, *An Introduction to Systematic Reviews*, 1st ed. Sage Publications Ltd, 2012. ISBN-13: 978-1849201810
- [12] N. Gavish, T. Gutiérrez, S. Webel, J. Rodríguez, M. Peveri, U. Bockholt, and F. Tecchia, "Evaluating virtual reality and augmented reality training for industrial maintenance and assembly tasks," *Interactive Learning Environments*, vol. 23, no. 6, pp. 778-798, 2015.
- [13] D. Zuehlke, "SmartFactory – Towards a factory-of-things," *Annual Reviews in Control*, vol. 34, no. 1, pp. 129-138, 2010.
- [14] I. Veza, M. Mladineo and N. Gjeldum, "Managing Innovative Production Network of Smart Factories," *IFAC-PapersOnLine*, vol. 48, no. 3, pp. 555-560, 2015.
- [15] A. Syberfeldt, M. Ayani, M. Holm, L. Wang. and R. Lindgren-Brewster, "Localizing Operators in the Smart Factory: A Review of Existing Techniques and systems," in *Proc. of 2016 International Symposium on Flexible Automation*, 2016, pp. 186-192, IEEE Computer Society.
- [16] C. Brecher, C. Ecker, W. Herfs, M. Obdenbusch, S. Jeschke, M. Hoffmann and T. Meisen, "The Need of Dynamic and Adaptive Data Models for Cyber-Physical Production Systems," in *Cyber-Physical Systems: Foundations, Principles and Applications*, pp. 3
- [17] S. Cawood and M. Fiala, *Augmented Reality: A Practical Guide*, 1st ed. Raleigh, NC: Pragmatic Bookshelf, 2008. ISBN 978-1934356036
- [18] R. Azuma, "A Survey of Augmented Reality," *Presence: Teleoperators and Virtual Environments*, vol. 6, no. 4, 1997.
- [19] N. Aquino, J. Vanderdonckt, N. Condori-Fernández, Ó. Dieste and Ó. Pastor, "Usability evaluation of multi-device/platform user interfaces generated by model-driven engineering", *Proceedings of the 2010 ACM-IEEE international symposium on empirical software engineering and measurement*, pp. 1-10, 2010.
- [20] S. Ghulamani and S. Zareen, "Educating students in remote areas using augmented reality", 2018.

# SOLAR POWERED OPERATED WATER TRASH COLLECTOR

Sonali . N. Wangikar  
(E&TC)

Assistant Professor  
AGTI'S Dr. Daulatrao Aher  
College of  
Engineering, Karad,415124  
India

Shidruk Omkar Rajendra  
(E&TC)

UG Student  
AGTI'S Dr. Daulatrao Aher  
College of Engineering,  
Karad, 415124  
India.

Khabale Ganesh Ankush  
(E&TC)

UG Student  
AGTI'S Dr. Daulatrao  
Aher College of  
Engineering  
Karad,415124  
India

Bhise Adarsh Dipak  
(E&TC)

UG Student  
AGTI'S Dr. Daulatrao Aher  
College of Engineering,  
Karad, 415124  
India

**Abstract**—All urban water bodies in India have been suffering from pollution since they are utilised to dispose of untreated local sewage and solid waste. These bodies of water frequently become landfills and accumulate garbage. Bangalore had 262 lakes before the beginning of the 1960s, but only 10 of them are still filled with water now. The fast urbanisation, increase in population, and declining water tables caused 44 lakes in Delhi to go dry in 2010–2011, which was used to examine changes in 3 water bodies during the previous ten years. The Indian government has launched numerous efforts and programmes to address these issues. Taking this into account, the goal of the "Solar Powered Water Trash Collector" project is to clean up water bodies by removing trash, debris, and solid waste. This idea's major goal is to cut down on the amount of time and labour needed to clean the river. The Pampa and "Namami Ganga" initiatives, which aim to clean rivers of wastes like dhoties, flower offerings, and other wastes, will also benefit from the use of this technology[3].

**Keywords**—BLDC – Brushless Direct Current Motor, BO Motor – Battery Operated Motor

## I. INTRODUCTION

Lakes and rivers are becoming polluted as a result of the growing urban population and expansion of enterprises[4]. The majority of floating solid debris that can be discovered in surface water includes beverage cans, plastic bottles, food packaging, containers, straws, and Styrofoam cups[5],[6]. These waste products, which are carelessly discharged into water bodies, injure not only people but also animals, plants, and other organisms[7],[8]. This project focuses on the design and construction of a river waste cleaning mechanism. The work was done using the current state of our national waterways, which are dumping crores of gallons of sewage and are loaded with pollutants, hazardous materials, trash, and so on. The Indian government has assumed care of river cleaning and has invested much in numerous river cleaning programmes. Taking this into consideration, this machine was built to clean the surface of a river. Almost all manufacturing processes

are now being atomized in order to provide products more quickly. Less than a third of the Earth's surface is made up of land, and two thirds of it is covered in water. People are placing more and more strain on the globe's water resources as the population of the planet rises. In a sense, human activities are "squeezing" our oceans, rivers, and other inland waters, lowering their quality. Water contamination results from poorer water quality. Mass production heavily relies on automation. This study focuses on skimmer boats, which are workboats used to gather and get rid of floating solid trash in harbours and waterways.

### A. Objectives

- 1) This paper aims to collect many types of wastes from water bodies and also reduces the human interference.
- 2) The collected waste from the equipment is disposed at easy way.
- 3) Solar based water trash collector is eco-friendly in nature and it is safe for the user.

## II. LITERATURE SURVEY

[1] Design and prototype development of portable trash collector.

Author Abdullah, MohdAzizudin and Endut introduced the trash collector boats are often designed in large size to cater to the high trash loading for surface water cleaning purpose. For small streams and drainage, the manual cleaning method is often used.

[2] Automatic Trash Removal System in Water Bodies.

Parakash and Markose proposed a disposal of household waste in rivers or lakes can lead to a decline in water quality and ultimately a significant impact on water pollution

[3] Automatic Trash Removal System in Water Bodies Parakash and Markose proposed a disposal of household waste in rivers or lakes can lead to a decline in water quality and ultimately a significant impact on water pollution.

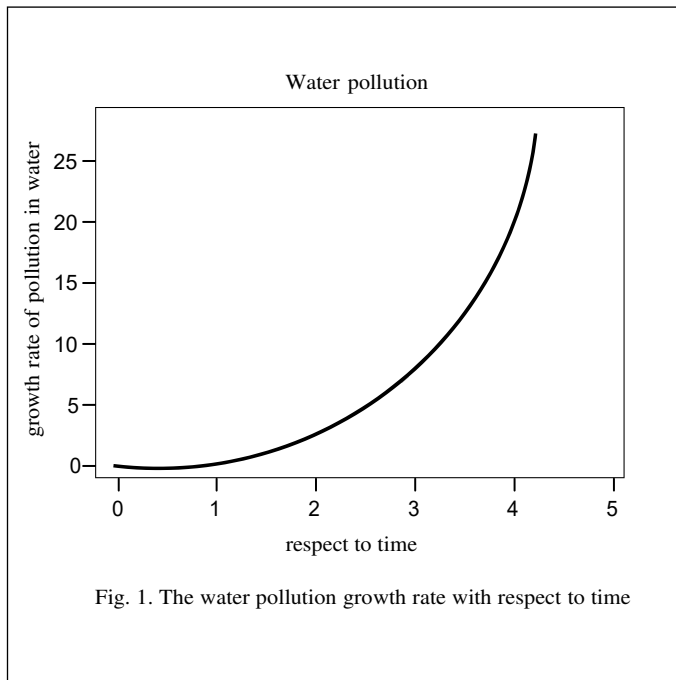

Fig. 1. The water pollution growth rate with respect to time

### III. WORKING PRINCIPLE

The primary goal is to start using solar energy instead of traditional energy sources to power trash collection machinery. Our technology collects the garbage using a belt conveyor system and deposits it in a chamber at the back. The shaft, which is set on the base frame, is bolted to the propeller. The machine can be moved forward or backward on water by the propeller. The waste collection conveyor is additionally powered by a separate motor. To steer the boat left or right, a servo motor-driven rudder is attached. In order to assess the quality of the water, a turbidity sensor is also attached on the rear of the vessel in order to monitor how cloudy or hazy the water is. Finally, the bin that is positioned within the boat is used to collect the floating trash.

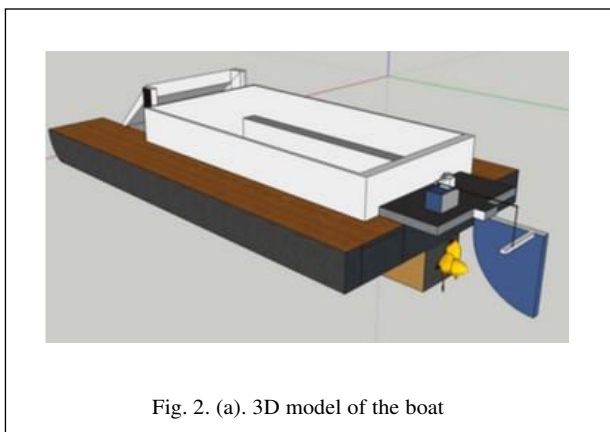

Fig. 2. (a). 3D model of the boat

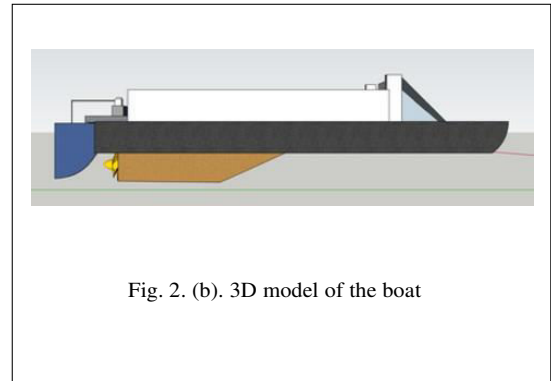

Fig. 2. (b). 3D model of the boat

### IV. HARDWARE REQUIRED

- Solar Panel
- BLDC Motor
- 11.1V battery
- Servo Motor
- Arduino Nano
- ESP 32
- BO Gear Motor (30 rpm)

*A. Solar Panel:* It is made up of a variety of photovoltaic cells that can produce power thanks to the photovoltaic effect. The batteries are charged using this energy, and DC regulators receive the output.

*B. BLDC Motor:* Direct-current electricity powers a brushless direct current motor (BLDC). Instead of the electromagnets used in induction motors, permanent magnets are employed in BLDC motors. Compared to electromagnets, the permanent magnet loses less energy and heat. Alternate current is converted into DC using a BLDC motor. The one deployed in this boat is a 1400kv motor.

*C. Battery:* We are utilising secondary battery type. The kind is rechargeable. One or more electrochemical cells that can store chemical energy and convert it to electric current make up a battery.

*D. Servo Motor:* Precision control of angular or linear position, velocity, and acceleration is made possible by the rotary actuator or linear actuator known as a servomotor (or servo motor). It comprises of a position feedback sensor coupled to a suitable motor. This motor's rudder control will be used to direct the movement of our boat.

*E. Arduino Nano:* The Arduino Nano, which was released in 2008, is a small, complete, and breadboard-friendly board based on the ATmega328P. It offers the same connections and characteristics as the Arduino Uno board but has a more compact form. The Arduino Nano may be programmed using the Arduino Software integrated programming environment (IDE), which is accessible both online and offline and is shared by all

Arduino boards. The Arduino Nano contains 30 male I/O headers that are organised in a DIP-30-like arrangement. A 9 V battery or a type-B mini-USB connector can power the board.

*F. ESP 32:* The ESP32 family of system on a chip microcontrollers features integrated Wi-Fi and dual-mode Bluetooth and is inexpensive and low power. The Tensilica Xtensa LX6 dual-core or single-core microprocessor, Tensilica Xtensa LX7 dual-core, or a single-core RISC-V microprocessor are used in the ESP32 series, which also has integrated antenna switches, RF baluns, power amplifiers, low-noise receive amplifiers, filters, and power-management modules.

*G. BO Gear Motor:* In this project we use a single 30 rpm bo gear motor to control the conveyor belt. This motor contains enough torque to rotate the conveyor with additional weight with much resistance.

## V. TECHNOLOGIES USED

### A. Android application

Mobile phones are installed with this Android application, which uses Wi-Fi to automatically control setup.

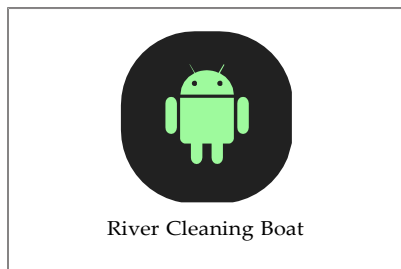

Fig. 2. Andriod application

## VI. IMPLEMENTATION

An android app is used to control the boat. The user interface of the application includes buttons to "start" and "stop" the motor as well as several angle calibrations for the servo motor. The signal is transmitted to the ESP, which receives it and then transmits the commands to the Arduino Nano. The output signals are then transmitted to the DC motor and servo motor via Arduino. The amount of light scattered by the suspended particles in the water is continuously measured by a turbidity sensor, which transfers the data to be displayed on our Android application.

## VII. CONCLUSION

In conclusion, the solar powered water trash collector

and pollution monitoring boat offers an innovative solution to the problem of water pollution. With the ability to navigate through various water bodies and detect levels of turbidity, the device can efficiently and effectively collect trash and other pollutants. The integration of solar power technology ensures that the device operates sustainably and reduces carbon emissions. The success of this project highlights the importance of interdisciplinary collaboration in addressing environmental issues. Moving forward, further research and development could enhance the efficiency and effectiveness of the device, leading to a cleaner and healthier environment. Overall, the solar powered water trash collector boat offers a promising solution for the mitigation of water pollution.

## VIII. FUTURE SCOPE

- **Commercialization:** With the increasing demand for sustainable and environmentally-friendly technologies, the solar powered water trash collector equipped with a turbidity sensor RC boat could be commercialized, leading to greater accessibility and affordability.
- **Research and Development:** Researchers could continue to explore ways to enhance the device's functionality, such as increasing its speed, range, and accuracy of the turbidity sensor.
- **Scalability:** As the device becomes more widely adopted, there may be opportunities to scale up its production and deployment, leading to greater impact on water pollution.
- **International adoption:** The solar powered water trash collector equipped with a turbidity sensor RC boat could be adopted by countries worldwide, leading to a global impact on water pollution.
- **Interdisciplinary collaboration:** The development of the device could involve collaboration among experts from various fields, such as engineering, environmental science, and policy, leading to innovative solutions to environmental challenges.
- **Public awareness:** The deployment of the device could increase public awareness of the issue of water pollution and encourage greater involvement in environmental stewardship.

## IX. REFERENCES

1. M. Mohamed Indris, M.Elamparathi, C. Manoj Kumar, Dr.N.Nithyavathy, Mr. K. Suganeswaran, Mr. S. Arunkumar, "Design and fabrication of remote controlled sewage cleaning Machine", *IJETT – Volume-45 Number2 -March 2017*.

2. Mr.Abhijeet.M. Ballade, Mr. Vishal.S. Garde, Mr.Akash.S. Lahane and Mr.Pranav.V.Boob, “Design & fabrication of river cleaning system”, *IJMTER* Volume 04, Issue 2, [February– 2017] ISSN (Online):2349–9745.
3. Mr. P. M. Sirsat, Dr. I. A. Khan, Mr. P. V. Jadhav, Mr. P. T. Date, “Design and fabrication of River Waste Cleaning Machine”, *IJCMES 2017 Special Issue-1* ISSN: 2455-5304
4. Rafique SMSM, & Langde A Design and fabrication of river cleaning machine. *Int. Jour. Sci. Adv. Res. Tech.* 2017;3(11):63–65
5. 8 Most Common Types of Garbage Found in the Ocean. Available on <https://www.banthebottle.net/articles/8-most-common-types-of-garbage-found-in-the-ocean> accessed on 10/03/2018
6. Sreenivasan J, Govindan M, Chinnasami M, & Kadiresu I. *Solid Waste Management in Malaysia – A Move Towards Sustainability. In Waste Management - An Integrated Vision. InTech. Publ. Ltd. 2012;*
7. Hua AK. Analytical and detection sources of pollution based environmetric techniques in Malacca river, Malaysia. *Appl. Ecolo. Environ. Res.* 2017;15(1):485–499
8. *The Ban on Microbeads – Why It Matters and Why It’s Still Not Enough* Available on <https://www.banthebottle.net/articles/the-ban-on-microbeads-why-it-matters-and-why-its-still-not-enough> accessed on 12/03/2018

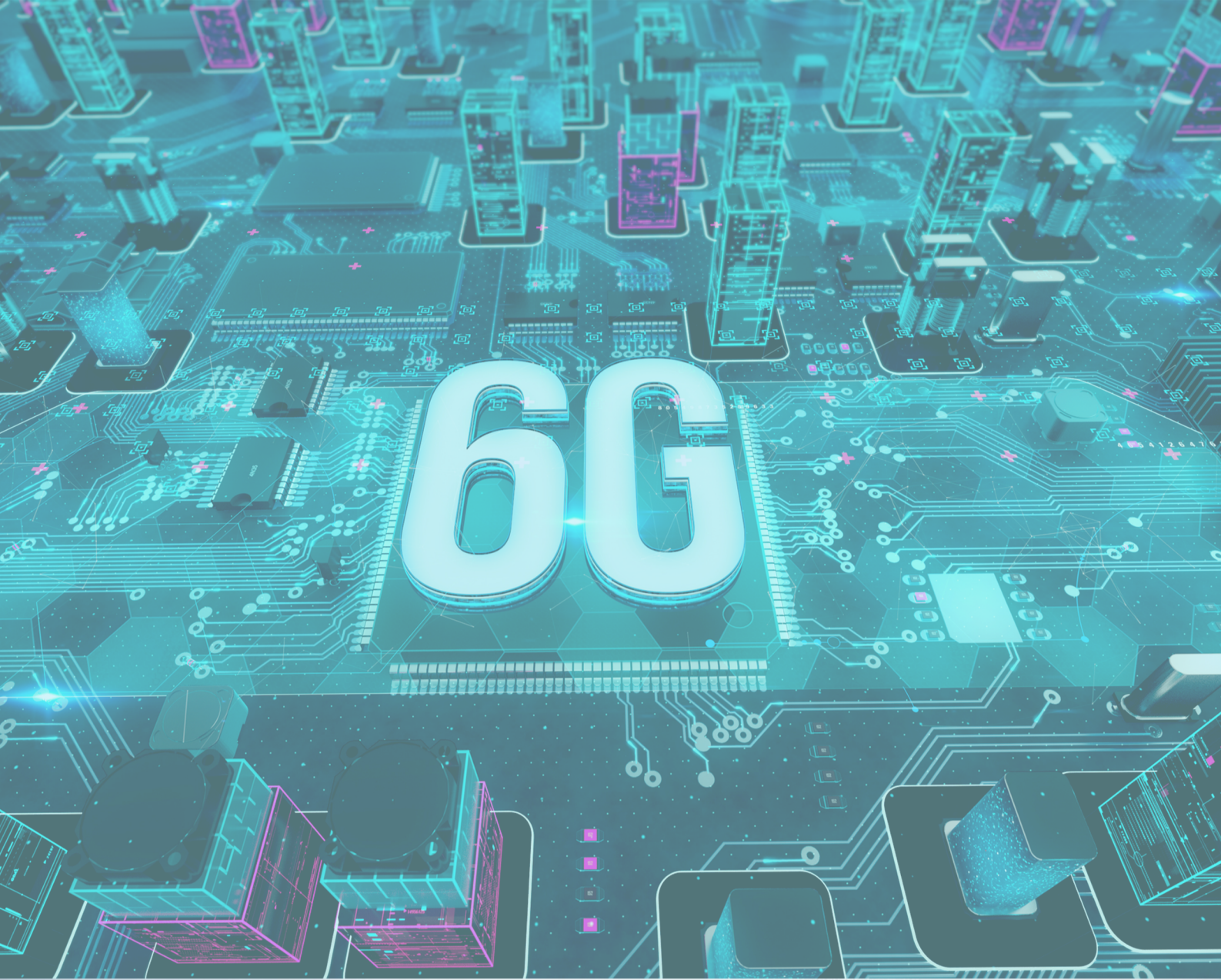

**SINHGAD INSTITUTE OF TECHNOLOGY , LONAVALA**

[sit.sinhgad.edu](http://sit.sinhgad.edu)



9788199224543