

National Level Student Conference

IEEE TECHNICOKNOCKDOWN-2024

TKD-24

Organized by Department of E&TC,
SIT Lonavla

Technically Sponsored by

IEEE Bombay Section
& IETE, Pune Center

April 20, 2024

Supported by
IEEE SITSB & IETEISF

ISBN No. 978-81-992245-6-7



Proceedings for

A National Level Student Conference



IEEE TECHNICO-KNOCKDOWN-2024

(TKD-24)

(April 20, 2024)

Organized by



Sinhgad Institutes

Department of E&TC Engineering Sinhgad
Institute of Technology, Lonavala

Documented and Prepared by

Dr. Dnyanesh S. Mantri

Dr. Prashant R. Dike

Mr. Vikram M. Chavan

with the inspiration and support of Dr. Manik S. Gaikwad



Disclaimer : This proceedings is based on the figures and facts available from different sources as authors Publications , and does not claim any responsibility regarding statements.



IEEE TKD-24

Copyright with Department of E&TC

All publishing rights (printed and ebook version) reserved with Department of Electronics and Telecommunication Engineering , Sinhgad Institute of Technology, Lonavala ..No part of this proceeding should be reproduced in any form, Electronic, Mechanical, Photocopy or any information storage and retrieval system without prior permission in writing,from Department of E&TC Engg. SIT Lonavala., Pune.



Sinhgad Institutes

Published By:

Department of E&TC in Association with IEEE Bombay Section and IETE Pune Local center



978-81-992245-6-7





National Level Student Conference



"IEEE TECHNICOKNOCKDOWN-2024 (TKD-24)"

Organized by Department of E&TC, SIT Lonavala



Technically Sponsored by IEEE Bombay Section and IETE, Pune Local Center



Supported by IEEE SITSB & IETEISF, SIT Lonavala

April 20, 2024

(Online mode)

Theme: Digital Transformation for Rural Upliftment



Chief Patron

Hon Prof. M. N. Navale, Founder President, STE Society, Pune

Hon Dr. (Mrs) S. M. Navale, Founder Secretary, STE Society, Pune

Hon Ms. Rachana Navale Ashtekar, Vice-President (Admin), STE Society, Pune

Hon Dr. Rohit M. Navale, Vice President (HR), STE Society, Pune

Organizing Chair

Dr. M.S. Gaikwad, Director, STES Campus, Lonavala

Principal, Sinhgad Institute of Technology, Lonavala

Dr. D. S. Mantri, Professor, HoD Dept. of E&TC, Dean Academics, SIT Lonavala Contact: +91-9922431612

Conveners

Dr. P. R. Dike, Asst Professor, Dept. of E&TC, SIT, Lonavala, Contact: +91-9422014174

Coordinator

Mr. M. K. Bhosale, Asst. Professor, Dept. of E&TC, SIT Lonavala [7588628575]

Student Branch Chairs

Sourabh Chakraborty, Chair IEEE SB, Lonavala, Contact: +91- 9834569666

Lokesh Singh, Chair IETE ISF, Lonavala, Contact: +91- 8320247541



Contents

- A. Welcome to TECHNICOKNOCKDOWN-2024
- B. About Sinhgad Institutes and SIT
- C. Mission & Vision
- D. Messages from Different Dignitaries
- E. Organising committee
- F. List of Reviewers
- G. TKD-24 Schedule
- H. List of Authors
- I. Track wise presented Papers



Welcome to

TECHNICOKNOCKDOWN-2024

It is our great pleasure to welcome you all for the virtual “TECHNICOKNOCKDOWN-2024 (TKD-24)” National Level Students Conference for technical paper presentation on April 20, 2024. The TKD-24 is organized by Department of Electronics and Telecommunication Engg, Sinhgad Institutes of Technology, Lonavala, Pune, Maharashtra. The conference is technically sponsored by IEEE Bombay Section and IETE, Pune local center and supported by IEEE SITSB and IETEISF, SIT Lonavala. TKD-24 provides an ideal platform for exchange of ideas among researchers, students, and practitioners.

TECHNICOKNOCKDOWN-2024 received research papers from all over India. TKD-24 received more than 55 papers out of which 32 regular papers are selected for the oral presentations after peer review and 25 finally received. The registered and presented papers are published in IEEE TKD-24 proceeding with ISBN No. 978-81-992245-6-7.

We hope that you will find this event interesting and thought provoking. TKD-24 will provide you with a valuable opportunity to share ideas with other researchers, students, and practitioners from institutions. We look forward to the contribution towards the event and see you virtually.

Team
TECHNICOKNOCKDOWN-2024

About STES:

Sinhgad Technical Education Society (STES) was set up in August 1993, under the able and dynamic leadership of Prof. M.N. Navale with an objective of providing quality education in the field of Engineering, Dentistry, Management, Computer, Pharmacy, Architecture, Hotel Management and the basic school education from kinder garden onwards. There are 58 institutes under the aegis of STES offering full-fledged school education, Diploma, Graduation, Post-Graduation courses and Ph.D. programs in various branches of Engineering, Science and Management at five educational campuses ideally located in pollution free lush green and picturesque environment conducive for learning. (sit.sinhgad.edu).

About SIT, Lonavala

Sinhgad Institute of Technology (SIT), Lonavala since its establishment in 2004 is involved in practicing teaching-learning methodologies of excellence to deliver quality engineering education for students all over India. The institute is housed in beautiful surroundings, fully residential campus of 220 acres on Pune-Mumbai expressway at Lonavala. Academic discipline with space for individual innovations, emphasis on life skill development of students, 'willing to work' team of faculty members and initiative for Industry interface, have been the silent activity of the college. Institute has following branches;

1. E&TC, Engineering
2. Mechanical Engineering,
3. Electrical Engineering,
4. Computer Engineering,
5. Information Technology &
6. Masters in Electrical and Power Systems

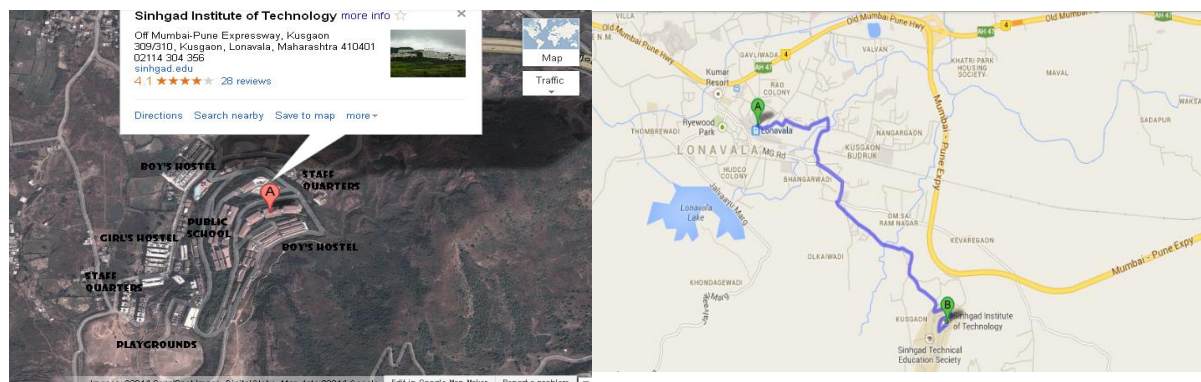



Vision and Mission of the Institute

VISION

उत्तमपुरुषान् उत्तमाभियंतृन् निर्मातुं कटीबध्दाः वयम्।

We are committed to produce not only good engineers but good human beings, also.

MISSION

Holistic development of students and teachers. We strive to achieve this by imbibing a unique value system, transparent work culture, excellent academic and physical environment conducive to learning, creativity and technology transfer.

Quality Policy

Quality Policy is aimed at achieving excellence in Technical Education with recognition at National & International level. Managements is committed to :

- Provide excellent Infrastructure facilities.
- Employ highly qualified & experienced faculty
- Encourage the faculty for qualifications improvement
- Promote the Industry- Institute Interaction
- Create environment for R & D activities, consultation work and getting Industry-sponsored projects for students
- A special internal Quality Assessment Program has been implemented which monitors all the parameters needed for achieving the goals
- Implementation of the Quality Policy will result in all round development of students relevant to the needs of Industries & will make them competent to face the challenges due to Globalization

Vision and Mission of the Department

VISION

The department of Electronics & Telecommunication is committed to grow on a path of delivering distinctive high quality education, fostering research, creativity and innovation.

MISSION

M1: The E&TC Department in partnership with all stake holders will harness talent, potential for application based indigenous product development in future.

M2: Our endeavor is to provide encouraging environment for life skill development of students while exercising effective learning strategies.

M3: We inculcate unique value system based on excellent academics in project based learning among students to explore and solve problems and challenges of realworld applications.



Short Term Goals

- To improve the results of UG classes
- To implement activity plan for overall development of students.
- To establish professional bodies/students forum for life skill development and expose students and faculty to latest business environment.
- To initiate relevant value addition programs and certifications for improving employability.
- To develop Laboratories for meaningful implementation of curriculum and then for Research.
- To encourage continuous up gradation of faculty members through higher education and external interface with other universities.

Long Term Goals

- To practice Project Based Learning (PBL) approach for UG program by creating collaborations with national and International institutions of reputation.
- To create opportunities for students to expose to industry environment through value addition programs and Industry projects for practical training.
- To foster research in the field of Electronics and Telecommunication Engineering for the benefit of society.
- IEEE International conference in the area of Wireless communication.

Program Educational Objectives (PEOs)

- PEO1** To develop students to achieve high level of technical expertise with Strong theoretical background and sound practical knowledge
- PEO2** To inculcate research environment for enhancement of Academia – Industry collaboration through conference
- PEO3** To prepare graduates to be sensitive to ethical, societal and Environmental issues while engaging their professional duties, Entrepreneurship and leadership.
- PEO4** To enhance ability of students for providing Engineering solution in a global and societal context
- PEO5** Pursue higher education for professional development.

Program Specific Outcomes (PSOs)

- PSO1** Get solid foundation in design and development of electronics modules useful to society.
- PSO2** Able to handle skills based challenges

Strength of Department is Faculty Team work to face any challenge



Principal's Message



Dear Friends,

I am extremely delighted to assert that Sinhgad Institute of Technology (SIT) is hosting a National level student conference “**IEEE Technicoknockdown-2024**” on April 20, 2024 at Sinhgad Technical Education Societies (STES) Campus Lonavala.

The TKD-24 has Theme of “**Digital Transformation for Rural Upliftment**”, and is very much aligned with the recent technological developments to 5G, 6G, Human Bond Communications and Industry 5.0 etc. The information and communication technology has made a profound impact on almost all sphere of social and personal life of human. The impact of these technologies is likely to continue unabated, therefore it is important that educators, scholars and technocrats keep themselves abreast with the latest trend of technologies. I am sure that the gap between industry and institute will be narrowed by these initiatives enabling mutual benefits and growth I believe that this conference will be an outstanding event for thousands of decision and policy makers , academicians , technocrats and educators.

I congratulate all my participants who have come from various colleges .I assure very delegate attending this event will experience the best academic ambience, hospitality and state of art infrastructural facilities. I am sure that the time spent by you all at Technicoknockdown-24.

A handwritten signature in blue ink, which appears to be 'M. S. Gaikwad'.

Dr. M. S. Gaikwad
Director STES Lonavala campus &
Principal, SIT, Lonavala



Message from Chair



Dear All,

It gives me an immense pleasure to thank all the participants and working team contributed in the virtual National Level Student Conference for technical paper presentation, “**TECHNICOKNOCKDOWN-2024**” with theme “**Digital Transformation for Rural Upliftment**” on April 20, 2024. TKD-24 is hosted by Department of Electronics and Telecommunication Engg, Sinhgad Institute of Technology, Lonavala, Pune, and Maharashtra. It is technically sponsored by IEEE Bombay Section and IETE, Pune local center, it is supported by IEEE SITSB & IETEISF, SIT Lonavala. The organizing committee of the **TECHNICOKNOCKDOWN-2024** is quite unanimous in their determination to make the event highly successful. Department of E&TC, SIT Lonavala always aims to provide the platform for “Willing to Work” professionals and researchers.

The tracks of TKD-24 are grouped broadly according to the theme

1. Internet of Things (IoT)
2. Artificial Intelligence and Machine Learning
3. Cyber Security
4. Communication Network
5. Media and Signal Processing
6. Electrical Vehicle
7. Advanced Smart Grids and Power Systems
8. Robotics and Automation
9. Others

TKD-24 received more than 55 papers out which only 25 were selected for the oral presentation after peer review. Also Skilled Session chairs are invited to evaluate the papers during presentations. Conference is imparting knowledge to more than 400 student participants to improve their skill sets.

I am quite pleased to mention that this event is successful in true spirit. This is only because of hard work, cooperation and dedication of all the coordinators as well as the participants, reviewers and faculties of the department. At the last, but not the least, I am thankful to Management of STES, Pune and Dr M. S. Gaikwad, Director STES Campus Lonavala, Principle SIT Lonavala & Organizing chairman TKD-24 for unstinting support to work as the convener of TKD-24.

Values are More Important than Valuables

A handwritten signature in blue ink, appearing to read 'Dnyaneshwar S. Mantri'.

Dr. Dnyaneshwar S. Mantri
Convener TKD-24



Faculty Advisor IETE Student's Chapter



It gives me immense pleasure to present proceedings of the "IEEE TECHNICOKNOCKDOWN-2024 (TKD-24)" National level student conference on Green Technology, Technically Sponsored by IEEE Bombay section and IETE ,Pune Center supported by IEEE SITSB and IETE, SIT Lonavala on April 20, 2024, organized by Dept of E&TC, Sinhgad Institute of Technology, Lonavala.

IEEE opens the door to opportunities that will help you develop your professional identity in IEEE's designated fields of interest: sciences, technology, engineering, and mathematics. I congratulate all participants for their contribution and valuable research in different tracks of IEEE TKD-24. I am enlightened to note that students of IEEE SIT student's chapter and IETE student chapter under the guidance of faculty members have taken this massive task as a challenge and I am confident that they will meet to the expectations of participants.

We are infinitely indebted to all the esteemed members of the Advisory Committees, reviewer team, for their invaluable advice and guidance in conception and organization of the conference. I gratefully acknowledge the full support and cooperation I received from all the organizing members along with our student coordinators, without their cooperation and help, this dream could not have been realized at all.

I am thankful to Dr. M. S. Gaikwad, Organizing chairman & Principal, Dr.S.D. Babar, Vice-Principal, & HOD, Dept. of E&TC, Dr. D. S. Mantri, Convener for Full support to work as the convener of this event.

With Most Respectful Regards

A handwritten signature in blue ink, appearing to read 'Prashant Dike', on a light-colored rectangular piece of paper.

Dr.Prashant Dike

Branch Counsellor IEIE ISF SIT Lonavala



Co-ordinator's Determination



It gives me an immense pleasure to welcome you all at a National level TPP “TECHNICOKNOCKDOWN-2024” organised by Dept. of E&TC SIT Lonavala. The event has brought to its success by both IETE & IEEE students chapter. The objective of IETE student's chapter is to segregate the technical knowledge and ideas to give a platform to students, researchers & developers through “TECHNICOKNOCKDOWN-2024”.

I am very much Thankful to all staff & student co-ordinators for their kind support throughout the event. At last but not least I am very much thankful to all the participants and wish you all the best for future

A handwritten signature in blue ink, appearing to read 'M. B.' with a horizontal line underneath.

Mr. Manoj K. Bhosale
Co-ordinator TKD-24



Message from, IETE Pune Center



Dr.Virendra. V. Shete

It gives me immense pleasure to know that Department of E&TC Engg. Sinhgad institute of Technology, Lonvala is organizing National level student conference “IEEE TECHNICOKNOCKDOWN-2024 (TKD-24)”. Technically sponsored by IETE, Pune center. I welcome all dignitaries & Participants, for the conference, Research articles are invited from the scholars on various tracks including Internet of things, (IoT) AI & ML, cyber security, Communication network, Media & signal processing, Green ICT, Advanced smart grids & Power systems & Robotics & automation.

I am hopeful that the conference will draw inspiring participation of Eminent scientists, Technocrats, Academicians & Industrialists will generate useful knowledge.

On this occasion on behalf of IETE, Pune center, I extend my warm greetings & best wishes for a successful organization of National conference & also for publishing a souvenir-cum proceedings of the conference.

Dr.V. V. Shete
Chairman, IETE, Pune Centre



Message from IEEE Bombay Section,



Dr. Shashikant S. Patil

I am pleased to welcome everyone to the IEEE TECHNICOKNOCKDOWN 2024 (TKD-24) Student National Conference, organized by Sinhgad Technical Education Society's SINHGAD INSTITUTE OF TECHNOLOGY (SIT) Lonavala Pune in association with IEEE Bombay section and IETE, Pune Center, supported by IEEE SITSB and IETE ISF SIT, Lonavala. The theme of this conference is Frontiers of Technologies: Next Generation Networks.

TKD-24 provides a platform to students within India to exchange thoughts about technology research in Artificial Intelligence and Machine Learning, Data Science and Analytics, Communication and Information security, Robotics, and Automation etc. These tracks in the conference have attracted a large volume of submissions from various states across India.

I take this opportunity to thank all the authors who submitted their papers and congratulate the authors of the selected papers that made it through the strict review process and have been selected for presentation.

I believe that the young researchers, who form a large percentage of the authors, would make the maximum use of this opportunity to engage with their peers and seniors to take a step towards leveraging technology for societal contribution and personal growth.

. .

Dr. Shashikant S. Patil
IEEE Bombay Section

Keynote Speaker Details



Prof. Sunil Kr Pandey, D.Sc. (Comp. Sc.), with over 25 Years of experience, presently working with I.T.S, Mohan Nagar, Ghaziabad, India as Professor & Director (IT & UG). He has a strong academic research track record with interest in Cloud, Blockchain, Database Technologies & Soft Computing and is credited 12 Patents granted in India & abroad, 01 Copyright Registered. Published 65+ Research papers (SCI/ Scopus Indexed)/ Book Chapters/ Articles with reputed publishers including Springer, IGI, IEEE, Wiley, Hindawi, reputed Journals/ Conferences. He has also published 04 Books on various topics in the field of Soft Computing including Machine Learning, Smart Technologies and IoT with Springer, River Press etc. He is a regular author of Articles in different Print and Online Platforms including Interviews, Views and has published 11 edited volumes on different relevant themes of Information Technologies. He has been providing & coordinating training and consultancy to various reputed organizations including Indian Air Force, Manipal Group, GDA etc. and has been speaking at different forums in India and abroad as speaker, panelist, Expert lectures and guest talks in various Summits/ Conclaves/National/International /conferences/Seminars. He is also a recipient of various awards & recognition from Academia and Industry including Dr. APJ Abdul Kalam Technical University Lucknow, CCS University Meerut, Global CIO Forum, APAC News Media, GEC Media, Business World, Dataquest, Business Standard, CISO Platform, IT Next Magazine, 9.9 Media Group, Enterprise IT Magazine, TechPlus Media Group etc. He has been associated with various Professional organizations including Sr. member of IEEE, ACM, Life Member of CSI, ISCA, IETE etc.

Details of Session Chairs



Dr. Nandkumar P. Kulkarni received Bachelor of Engineering (B.E.) degree from Walchand College of Engineering, Sangli, Maharashtra, (India) in 1996. He completed a Master of Technology (M. Tech) degree with computer specialization from COEP, Pune (India) in 2007 and Ph.D. from Aarhus University, Denmark in 2019. He has been with Electronica, Pune from 1996 -2000. He worked on retrofits, CNC machines and was also responsible for PLC programming. In 2000, he received the Diploma in Advanced Computing (C-DAC) degree from MET's IIT, Mumbai. In 2002, He became Microsoft Certified Solution Developer (MCSD). He worked as a software developer and system analyst in CITIL, Pune and INTREX India, Mumbai respectively. He has 24 years of experience both in industry and academia. From 2002 onwards he is working as a faculty in Savitribai Phule Pune University, Pune. Currently is working with MID ADT University as a faculty in IT Department. His area of research is in WSN, VANET, and Cloud Computing. He has published papers in 18 International Journals, 15 International IEEE conferences, 03 National Conferences



Dr. Vandana Baste Rohokale received her B.E. degree in Electronics Engineering in 1997 from Pune University, Maharashtra, India. She received her Masters degree in Electronics in 2007 from Shivaji University, Kolhapur, Maharashtra, India. She has received her PhD degree in Wireless Communication in 2013 from CTIF, Aalborg University, Denmark. She has completed her post doctorate from ARHUS University under the guidance of Prof. Ramjee Prasad in 2023. She is presently working as Professor, Head and Vice Principal in Sinhgad Institute of Technology and Science, Pune, Maharashtra, India.

Her teaching experience is around 26 years. She has published four books of international publication. She has published around 60 plus papers in various international journals and conferences. Her research interests include Cooperative Wireless Communications, AdHoc and Cognitive Networks, Physical Layer Security, Digital Signal Processing, Information Theoretic security and its Applications, Cyber Security, Artificial Intelligence and Machine Learning, Quantum Computing, etc



Prof. Abdul Hameed Ansari, Work experience. 24 years B.E (E&TC) in 1997. M.E. (Digital Electronics) in 2005 from Sant Gadge Baba Amravati University Amravati. Pursuing PhD from Sant Gadge Baba Amravati University Amravati as well. Worked for Poonitronics (India) Pvt. Ltd, Pune as Design Engineer, Worked in Rajaram Shinde College of Engineering, Pedhambe for eight years under Mumbai University,

Working as an Associate Professor in Pravara Rural Engineering College, Loni since 2006, Worked in various capacities like, Convener for the Pravara Institute of Skill Development, Loni., Minority Scholarship Cell Officer, working as the principal investigator for SC/ST skill and Personality Development Cell, Convener for International Conference and National Conferences at PREC, Loni., Skill Development Coordinator under NSDC., Principle investigator for various AICTE based funded schemes, He has published more than 23 papers in national and international conferences.



Dr. Dipak S. Raskar received Bachelor of Engineering (B.E.) degree from ADCET, Ashta, Sangli, Maharashtra, (India) in 2009. He completed a Master of Engineering (M.E.) degree in Electronics and Telecommunication Engineering from JJMCOE, Jaysingpur (India) in 2015 and Ph.D. from SGV University, Jaipur in 2023.. He has 15 years of experience in academia. Currently is working with Amity University, Mumbai as faculty in CSE Department. His area of research is in Embedded System, IOT, and Waste Management.

He has published Total 9 papers in reputed International Journals, 03 National Conferences.



Ms. Shital K. More
Session Incharge



Dr. V. G. Rajeshwarkar
Session Incharge



Mr. Anand A. Labade
Session Chair



Dr. Prashant R. Dike
Session Incharge

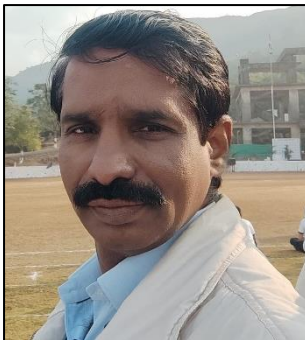

Mr. Vikad D. Raskar
Technical Incharge



Mr. Vikram M. Chavan
Editor

Our Chief Patrons

Sinhgad technical Education Society, Pune



Prof. M. N. Navale
Founder President,
Sinhgad Institutes, Pune



Dr.(Mrs) Sunand M . Navale
Founder Secretary,
Sinhgad Institutes, Pune



Dr.Rohit M. Navale
Vice President (HR),
Sinhgad Institutes, Pune



Ms. Rachana Navale Ashtekar
Vice President (Admin)
Sinhgad Institutes, Pune



Advisory Body and Organizing Committee

Advisory Committee

Dr. Shashikant S Patil, IEEE Bombay Section
 Dr. Vinit Kotak, IEEE Bombay Section
 Dr. Samir, IEEE Bombay Section
 Mr. Anand Gharpure, IEEE Bombay Section
 Dr. Satyanarayana Bheesette, Immediate past Chair, IEEE Bombay Section
 Mr. Kiran Talele, IEEE Bombay Section
 Dr. Saurabh Mehta, IEEE Bombay Section
 Mr. Dattaraya Sawant, IEEE Bombay Section
 Dr. Sarika Chouhan, Immediate past, Member, Chair SAC, IEEE Bombay Section
 Dr. V. V. Shete, Chairman IETE, Pune local center
 Dr. R. D. Kharadkar, Immediate Past, Chairman IETE, Pune Local Center
 Dr. D. G. Bhalke, Secretary, IETE, Pune Center
 Dr. Sunil Somai, Treasurer, IETE Pune, Local Center
 Mr. S. M. Gaikwad HOD. Mech Dept., SIT Lonavala
 Dr. S. D. Babar HOD, Comp. Dept., SIT Lonavala
 Mr. S. D. Datey HOD, Elect. Dept., SIT Lonavala
 Dr. P. S. Patil HOD, FE Dept., SIT Lonavala
 Dr. R.V. Babar, HOD, IT Dept., SIT Lonavala

Organizing Chairman

Dr. M.S. Gaikwad, Director, STES Campus Lonavala
 Principal, Sinhgad Institute of Technology Lonavala

Convener

Dr. D. S. Mantri, Professor, Dept. of E&TC, SIT Lonavala
 Dr. P. R. Dike, Asst. Prof., Dept. of E&TC, SIT Lonavala

Co-ordinator

Mr. M. K. Bhosale Asst. Prof., Dept. of E&TC, SIT Lonavala

Session Coordinator

Mr. V.D. Raskar, Dept. of E&TC, SIT Lonavala

Publication (Editorial) Committee

Mr. V. M. Chavan, Asst. Prof., Dept. of E&TC, SIT Lonavala
 Mr. Saurabh Chakrawarthy, Student Chairman, IEEE SITSB
 Mr. Lokesh Singh, Student Chairman, IETEISF

Technical Support

Ms. R. D. Mantri, Dept. of Mechanical Engineering, SIT Lonavala
 Ms. D. S. Mali, Dept. of E&TC, SIT Lonavala
 Ms. S. B. Pandit, Dept. of E&TC, SIT Lonavala
 Mr. V. B. Mali, Dept. of E&TC, SIT, Lonavala

Organizing committee

Dr. S. B. Gholap	Ms. C. A. Mhetre	Mr. Shrinivas Wage
Ms. S.S. Patil	Mr. S.S. Salve	Mr. Harshad Bhapkar
Mr. A. A. Labade	Mr. S. S. Asane	Ms. Sejal Mehta
Dr. V.G. Rajeshwarkar	Ms. Shubhanu Muthukumar	Ms. Tanvi Sheety
Ms. S.K. More	Mr. Samarth Kasu	
Mr. S.A. Bhad	Ms. Shivani Kadam	
Ms. P. S. Mhetre	Ms. Shrutika Girhe	
Mr. M.S. Raut	Mr. Harshad Bhapkar	



List of Reviewers

1. Dr. Pranav Pawar, BITS Pillani, Duabi
2. Mr. Manoj K. Bhosale, SIT Lonavala
3. Mr. Nilesh Lakade, K. J. Somaiya Mumbai
4. Dr. Dnyaneshwar.S. Mantri, SIT Lonavala
5. Mr. Vikram M. Chavan , SIT Lonavala
6. Mr.Vinayak Gaikwad, SIT lonavala
7. Mr. Nishant N. Pachpor,
8. Dr. Sachin Jadhav, PCCOE Pune
9. Mr. Virendta Bagade, PICTE, Pune
10. Dr. Shubhangi Patil, JIMCOE, Jaisighpur
11. Ms. Seema Patil, Asokrao Mane College Watar
12. Mr. Shripad S Velling, Shindhudurga Subcampus, Mumbai
13. Savita Itkalkar, Bharti Vidyapeeth Pune,
14. Dr. Manju Pawar, MIT, Aurangabad
15. Mr.Shankar R. Madkar,Bharti vidyapeeth,Pune
16. Mrs.Sonam Singh,DYPatil Pimpari,Pune
17. Dr.D.S.Raskar,Amity university,Mumbai
18. Dr.Dipali Shende,PCCOER,Pune
19. Mrs.Shubhangi V.Gaikar,MIT,Alandi,Pune
20. Dr.Jyoti Gangane,Vishwaniketan college Mumbai
21. Dr.Swati Shetkar,M.S.Bidve Engg collge ,Latur
22. Dr.Laxmikant Gaud, Sandipani Technical Campus, Latur
23. Dr. Shivleela Mudda, M.S.Bidve Engg. College, Latur
24. Dr. Sanjivani Kulkarni, Sandipani Technical Campus, Latur
25. Dr. Prashant Dike, SIT Lonavala
26. Dr. B. Satheesh, Vaagdevi College of Engineering, Warangal-Telangana State
27. Dr. Dhananjay D Khumane, Shree Tuljabhavani College of Engg. Tuljapur
28. Mrs. Vaishal S. Baste, SKNCOE, Pune



Sinhgad Technical Education Society's

SINHGAD INSTITUTE OF TECHNOLOGY, LONAVALA

Department of Electronics and Telecommunication Engineering

**National level Student Conference IEEE TECHNICOKNOCKDOWN-2024 (TKD-24)**

Technically Sponsored by IEEE Bombay section and IETE, Pune center supported by IEEE SITSB and IETE SIT, Lonavala



Schedule - Session I,II,III,IV



Saturday, April 20, 2024

Inauguration : 10.00 am to 10.30 am		https://shorturl.at/cxHIP			
Keynote Speaker: 10.30 am to 11.15 am		Dr.Sunil Kumar Pandey, Director,ITS Mohan Nagar,Ghaziabad "Next Generation Network: Using Blockchain Technology"			
Artificial Intelligence and Machine Learning -1					Session-I
Session-I Link		https://meet.google.com/fsj-hwhc-dcx			
SN	Time	Paper ID	Title of Paper	Author Name	Coordinator/Chair
1	11.15 am to 1.15 pm	AIML-01	EMPOWERING MUNICIPAL COOPERATION: A CHATBOT APPROACH FOR ENHANCED SERVICE DELIVERY	Vasudha Kulkarni	Student Coordinator
2		AIML-03	HAND SIGN TO TEXT CONVERTER	Ajay Krishna Jagdale	Shrutika Girhe 7499395568
3		AIML-05	DEEP LEARNING ASSISTED SIGNATURE VERIFICATION SYSTEM	Ashish A Kulkarni	Session Coordinator
4		AIML-08	EMBEDDED SYSTEM BASED MEDICINE ASSISTANT AND DISPENSER POWERED BY AI	A.R.Salunke	Dr.V.G.Rajeshwarkar 9923103439
5		AIML-10	HYBRID ENERGY INSPIRED DC MICRO-GRID SYSTEM USING MACHINE LEARNING	Samruddhi Khairnar	Session Chair
6		AIML-12	REVOLUTIONIZING HEALTHCARE: EARLY DETECTION OF SKIN CANCER THROUGH INNOVATIVE IMAGING TECHNOLOGY	Rohan Ravi Dash	Dr. Abdul H. Ansari
AI-ML 2 + CS +EV					Session-II
Session-II Link		https://meet.google.com/fvr-xaxe-pzq			
SN	Time	Paper ID	Title of Paper	Author Name	Coordinator/Chair
1	11.15 am to 1.15 pm	AIML-15	AI BASED SMART COMPREHENSIVE SUPPORT SYSTEM FOR SENIOR CITIZENS	Chetana Patil	Student Coordinator
2		AIML-16	DESIGN PAPER ON POLICE PREVENTIVE ACTION TRACKING SYSTEM USING AI	Shubham Mane	Shubhanu Muthukumar 9607264735
3		AIML-17	AI ENABLED MANNED UMANNED TEAMING WITH DRONE	Niksha Atul Mahajan	Session Coordinator
4		AIML-18	AUTOMATED DENTAL CAVITY DETECTION SYSTEM USING DEEP LEARNING	Dr. Deepali Ujalambka	Mrs. Shital More 9923049992
5		CS-01	AN IN-DEPTH ANALYSIS OF SPAM EMAIL: REVIEW ON FREE SPAM EMAIL DATA CORPUS	Kalyani Shivaji Ubale	Session Chair
6		EV-01	BMS ANS MOTOR CONTROL FOR RANGE EXTENDED ELECTRIC VEHICLES (REEV)	Mahesh Satish Gujarathi	Dr.Vandana M.Rohokale
ASGP + CN + IOT					Session-III
Session-III Link		https://meet.google.com/coz-zsqh-ixu			
SN	Time	Paper ID	Title of Paper	Author Name	Coordinator/Chair
1	11.15 am to 1.15 pm	ASGP-01	PLATFORM FOR TRADING ENERGY BETWEEN PEERS FOR RESIDENTIAL POWER SYSTEMS	Nachiket Nawatakke	Student Coordinator
2		CN-02	ENERGY-EFFICIENT CRITICAL EVENT MONITORING FOR EPILEPSY PATIENT CARE IN WIRELESS SENSOR NETWORKS	shital pandurang shinde	Tanmay Dharmik 9322311023
3		CN-03	LIFI TECHNOLOGY	Swant Anurag Ramkrishna	Session Coordinator
4		IOT-07	SMART DOOR LOCK SYSTEM	Neha Pramod Gondhali	Mr.Anand Labade 9423224759
5		IOT-10	SMART WASTE MANAGEMENT SYSTEM	Jaydev M. Karad	Session Chair
6		IOT-11	GPS AND GSM BASED VEHICLE TRACKING SYSTEM AND ENGINE LOCKING US	Vijay Kunte	Dr. Nandkumar P. Kulkarni
Others (OT)					Session-IV
Session-IV Link		https://meet.google.com/stt-eipz-kgf			
SN	Time	Paper ID	Title of Paper	Author Name	Coordinator/Chair
1	11.15 am to 1.15 pm	OT-03	SCALING GOOGLE: WITH ADVANCEMENT AND INNOVATIONS IN SCALABILITY FEATURES.	Mrs. Shweta Thorat	Student Coordinator
2		OT-04	WIRELESS SENSOR NETWORK TO MINIMIZE ENERGY CONSUMPTION USING ALGORITHM	Prashant dike	Tanvi Shetty 9607628860
3		OT-05	ENHANCING AGRICULTURAL PRODUCTIVITY THROUGH NDVI PRECISION FARMING FOR SUSTAINABLE CROP MANAGEMENT.	Supriya Suresh Nakade	Session Coordinator
4		OT-06	FINGERPRINT BASED ELECTRONIC VOTING MACHINE	Bhakti Pansare	Dr.Prashant R.Dike 9422014174
5		OT-08	FOOD RECOGNITION AND CALORIES MEASUREMENT BY USING MACHINE LEARNING	Pallavi Ghuge	Session Chair
6		OT-09	SOLAR BASED ROBOT VEHICLE FOR LANDMINE DETECTION.	Shital More	Dr. Deepak S.Raskar
7		OT-10	DESIGN OF WEB BASED STUDENT INFORMATION SYSTEM	Anuj Dhupal	

Dr. D. S. Mantri
Convener TKD-24
HOD E&TC, SIT LonavalaDr. M.S. Gaikwad
Organizing Chair TKD-24
Principal, SIT Lonavala



National Level Student Conference

"IEEE TECHNICOKNOCKDOWN-2024 (TKD-24)"

Organized by Department of E&TC, SIT, Lonavala

(Online Mode)

INDEX

SR. NO.	PAPER ID	TITLE	AUTHORS	PAGE NO:
1	AIML-01	Empowering Municipal Cooperation: A Chatbot Approach for Enhanced Service Delivery	Vasudha Kulkarni	1
2	AIML-03	Hand Sign to Text Converter	Ajay Krishna Jagdale	5
3	AIML-05	Deep Learning Assisted Signature Verification System	Ashish A Kulkarni	10
4	AIML-08	Embedded System based medicine assistant and dispenser powered by AI	Aarti Salunke	15
5	AIML-10	Hybrid Energy inspired DC Micro-grid System using Machine Learning	Samruddhi Khairnar	19
6	AIML-12	Revolutionizing Healthcare: Early Detection of Skin Cancer through Innovative Imaging Technology	Rohan Ravi Dash	24
7	AIML-15	AI Based Smart Comprehensive Support System For Senior Citizens	Chetana Patil	29
8	AIML-16	Design Paper on Police Preventive Action Tracking System Using AI	Shubham Mane	35
9	AIML-17	AI Enabled Manned Umanned Teaming With Drone	Niksha Atul Mahajan	40
10	AIML-18	Automated Dental Cavity Detection System Using Deep Learning	Dr. Deepali Ujalambkar	45
11	IOT-07	Smart Door Lock System	Neha Pramod Gondhali	49
12	IOT-10	Smart Waste Management System	Mr. Jaydev M. Karad	52
13	IOT-11	GPS and GSM Based Vehicle Tracking System and Engine Locking Using Arduino	Vijay Kunte	56
14	CN-02	Energy-Efficient Critical Event Monitoring For Epilepsy Patient Care In Wireless Sensor Networks	Shital Pandurang Shinde	60
15	CN-03	LiFi Technology	Sawant Anurag Ramkrishna	65
16	CS-01	An In-Depth Analysis of Spam Email: Review On Free Spam Email Data Corpus	Kalyani Shivaji Ubale	70
17	ASGP-01	Platform For Trading Energy Between Peers For Residential Power Systems	Nachiket Nawatakke	76
18	EV-01	BMS and Motor Control For Range Extended Electric Vehicle (REEV)	Mahesh Satish Gujarathi	81



19	OT-03	Scaling Google: With Advancement and Innovations In Scalability Features.	Mrs. Shweta Thorat	85
20	OT-04	Wireless Sensor Network to Minimize Energy Consumption Using Algorithm	Dr.Prashant Dike	91
21	OT-05	Enhancing Agricultural Productivity Through NDVI Precision Farming for Sustainable Crop Management.	Supriya Suresh Nakade	97
22	OT-06	Fingerprint Based Electronic Voting Machine	Bhakti Pansare	101
23	OT-08	Food Recognition and Calories Measurement By Using Machine Learning	Pallavi Ghuge	107
24	OT-09	Solar Based Robot Vehicle For Landmine Detection.	Shital More	113
25	OT-10	Design of Web Based Student Information System	Anuj Dhumal	117



Dr. D. S. Mantri
Convener TKD-24

Dr. M. S. Gaikwad
Principal, SIT Lonavala

Empowering Municipal Cooperation: A Chatbot Approach for enhanced Service Delivery

¹Kulkarni Vasudha Sanjay,

²Naikwade Vaishnavi Shamrao,

³Radhakrishna Naik

¹Student, Department of CE, College of Engineering and Technology, College of Engineering and Technology, Sanjivani College of Engineering, Kopargaon - 423601 India

²Student, Department of CE, College of Engineering and Technology, College of Engineering and Technology, Sanjivani College of Engineering, Kopargaon - 423601 India

³Data Scientist, Department of CE, College of Engineering and Technology, College of Engineering and Technology, Sanjivani College of Engineering, Kopargaon - 423601 India

ABSTRACT:

The work we present provides a comprehensive chatbot system for municipal corporation services, which will bolster citizen engagement, a challenge faced by municipal corporations that provide residents with the critical day-to-day services they need. The system we have implemented is an intelligent chatbot powered by cutting-edge algorithms for processing natural language (Natural Language Processing, NLP) and learning from data including reinforcement learning, providing modern and efficient access for citizens to find almost any information they require in a city. The chatbot is trained to process an extensive array of the kinds of inquiries typically posed to municipal corporations. These include basic questions such as the schedule for garbage disposal, to initiating actions such as paying a utility bill, to reporting problems with municipal infrastructure, to questions regarding the dates and times of, and locations of, civic events.

Keywords: Service Delivery, Natural Language Processing (NLP), User Queries, Civic Events, Modernization, Efficiency

Introduction:

Municipal corporations play a crucial role in urban

Literature Review:

1) **Conference/Journal:** Published in 2018 8th International Conference on Communication System and Network Technologies.

governance, providing essential services to residents. However, the increasing complexity of urban issues and the growing population often result in challenges related to communication, service delivery, and information dissemination.

To address these challenges, there is a need for an intelligent and user-friendly chatbot tailored for municipal corporations. People visit a municipal corporation office or visit their websites to access their services.

The use of mobile phones has increased drastically. 91% of world population owns mobile phone, out of which 56% own a smart phone. Mobile is the primary internet source for 50% of the mobile users. It is also observed that users spend 80% of their time inside applications.

This application resembles municipal corporation services. Various services are provided through this application.

User can access these services from anywhere & anytime through mobile application is based on Common Man interaction with Computational device along with the benefits of interaction with Municipal Corporation. with Computational device along with the benefits of interaction with Municipal Corporation.

Paper Title: “SMART CITY”: Municipal Corporation Services for Human Welfare

Author: Akshay Abhyankar, Ashwini Bhoir, Harshit Damani, Ashwini Sav.

People visit to a municipal corporation offices or visit their websites to access their services. Use of mobile has increased drastically. 91% of world population owns mobile phone, out of which 56% owns a smart phone. Mobile is the primary internet source for the 50% of the mobile users. It is also observed that user spent 80% of time inside applications. This application resembles municipal corporation services. Various services are provided through this application. User can access these services from anywhere & anytime through mobile application is based on Common Man interaction. Applications of CHATBOT, showcasing its potential to enhance communication and productivity invarious domains.

3) **Conference/Journal:** Published at-International Journals of Advanced Research in Computer Science and Software Engineering 8 (2018), pp. 53–56.

Paper Title: A review paper on human computer interaction.

Author: Himanshu Bansal and Rizwan Khan.

The authors propose a review paper on Human-Computer Interaction (HCI). They discuss the advancements in computer technology and how it has led to the development of HCI, which focuses on highlighting its practical applications in industries such as customer service, banking, and education. The paper also proposes the utility of CHATBOT in computer-aided design (CAD) applications. The document includes a historical account of CHATBOT development and explains the necessary steps in

Methodology:

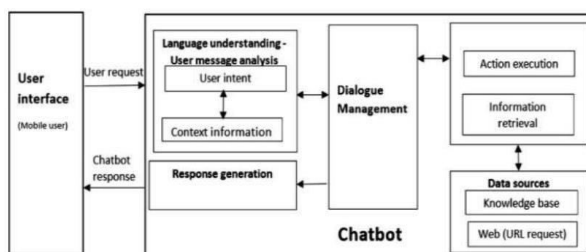

Fig.1 Message flow

1. User Interface: Accepts user queries and serves as the entry point for interaction.

2. User Message Analysis Component: Parses user

2) **Conference/Journal:** Journal of Computing and Communication Vol.2 , No.1 , PP. 20-28 , April 2021.

Paper Title: Design and Development of CHATBOT: A Review

Author: Rohit Tamrakar and Niraj Wani

The document "Design and Development of CHATBOT: A Review" provides a comprehensive review of CHATBOT, an emerging tool for learning. It discusses the technique, terminology, and platforms used in the design and development of CHATBOT, designing a CHATBOT. It also discusses the architecture, types, and engineering approaches used in CHATBOT development. Overall, the paper provides valuable insights into the design, development, and the usability and interaction between humans and computers. The paper highlights the importance of the mental model in HCI and explores various approaches in HCI design, such as anthropomorphic, cognitive, empirical, and predictive modeling approaches.

They also delve into the concept of fidelity prototyping and emphasize the role of participants in HCI experiments, particularly the younger age group. The authors suggest that HCI is likely to become a prominent research topic within the artificial intelligence (AI) community, with the potential to bring about radical changes and improve user experiences. Overall, the paper emphasizes the user-centered nature of HCI and anticipates that even small advancements in this field will have a significant impact on people's lives.

input messages to deduce intent and identify associated entities.

3. Dialogue Manager: Manages conversation context, updating it to determine appropriate actions based on user input.

4. Data Sources: Retrieves data of interest from various sources, including databases or external resources through API calls.

5. Response Generator: Prepares natural language responses based on intent and context information derived from the user message analysis component. Fig.1 illustrates the chatbot components [2].

Workflow:

1. The message is received and passed to an Interpreter, which converts it into a dictionary including the original text, the intent, and any entities that were found. This part is handled by NLU.
2. The message is passed from the Interpreter to the Tracker. The Tracker is the object which keeps track of

conversation state.

3. The current state of the tracker is sent to each policy.
4. Each policy chooses which action to take next.
5. The chosen action is logged by the tracker.
6. A response is sent to the user.

Challenges:

Municipalities serve a diverse population with varying levels of technological literacy and language preferences.

Municipalities often have legacy systems that may be outdated and not easily integrated with modern chatbot technologies.

Handling sensitive citizen data requires robust security measures to ensure compliance with data protection regulations.

SNAPSHOT:

FUTURE WORK:

Building trust among users regarding the reliability and security of interacting with a chatbot for municipal services.

Machine Learning for Continuous Learning: Implementing machine learning algorithms will allow chatbot's to learn and adapt over time

Voice and Visual Interaction: Integrating voice and visual components into chatbot's will enable users to interact through speech, images, and videos, expanding accessibility and engagement.

Natural Language Processing (NLP) Advancements: Continued improvements in NLP will enable chatbot's to better understand and respond to complex user queries.



Chatbot for Municipality

0 people like this
Social media agency

VIEW PROFILE

7:23 PM

Hello

Hello! I am Municipalty-Bot
How can I assist you
today?

Tell me SOP for water
supply

The Standard Operating
Procedure (SOP) for water
management covers the
sourcing, treatment, and
distribution of water, along
with measures for water
conservation and quality
control.

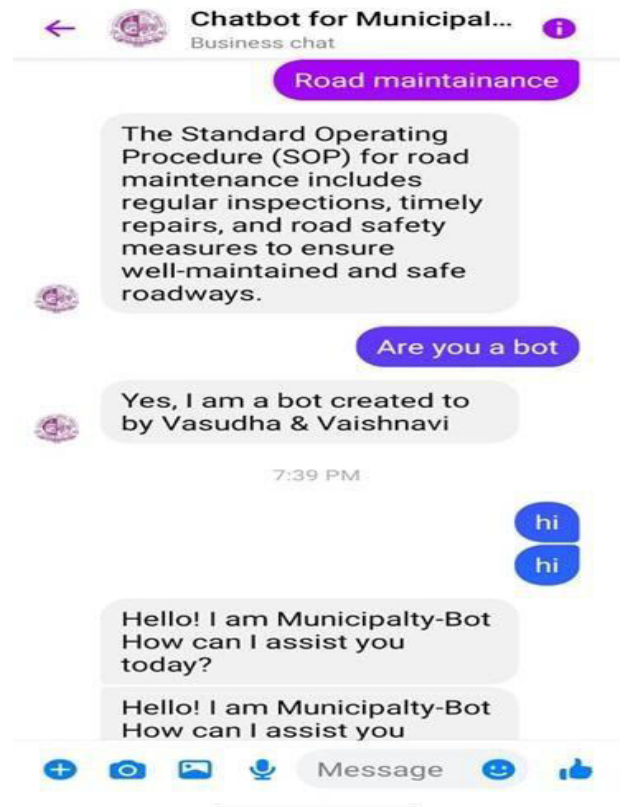

REFERENCE:

[1] Walaa Hassan, Shereen elBohy ,Mina Rafik , Ahmed Ashraf ,Sherif Gorgui , Michael Emil , Karim Ali “An interactive chatbot for college enquiry” published at- Journal of Computing and Communication Vol.2 , No.1 , PP. 20-28 , 2023

[2] Rohit Tamrakar and Niraj Wani “Design and Development of CHATBOT: A Review” published at- Journal of Computing and Communication Vol.2 , No.1 , PP. 20-28 , April 2021

[3] Himanshu Bansal and Rizwan Khan. "A review paper on human computer interaction". International Journals of Advanced Research in Computer Science and Software Engineering 8 (2018), pp. 53–56

[4] Chinedu Wilfred Okonkwo and Abejide Ade-Ibijola “Chatbots applications in education: Asystematic review” published at- sciencedirect Computers & Education: Artificial Intelligence ,2021

Hand Sign to Text Converter

Ajay Jagdale
 Department of Information Technology
 Sinhgad Institute Of Technology
 Lonavala, India
 ajay.ajgdale2002@gmail.com

Ashwini Dalvi
 Department of Information Technology
 Sinhgad Institute Of Technology
 Lonavala, India
 ashwindalvi007@gmail.com

Pratiksha Ghosale
 Department of Information Technology
 Sinhgad Institute Of Technology
 Lonavala, India
 pratikshaghosale22@gmail.com

Ritesh Zaware
 Department of Information Technology
 Sinhgad Institute Of Technology
 Lonavala, India
 zawareritesh126@gmail.com

Abstract— Voice and Language are the main things that help humans to communicate with each other. Due to hearing ability, we can understand the thoughts of each other. Now, we can give commands using voice recognition. But if one cannot hear anything and eventually cannot speak? So, Sign Language is the basic communication tool for people hard of hearing and mute people and to ensure an independent life for them. The automatic interpretation of sign language is an immersively wide research area. With image processing and artificial intelligence, many techniques and algorithms are in this area. Every sign language recognition system is trained to recognize the signs and convert them into the required patterns. The proposed system aims to provide speech to the speechless. In this project, the doublehanded Indian Sign Language was captured as a series of images, then processed with the help of Python, and then converted to speech and text. This project serves as a tangible example of how technology can be harnessed to address communication barriers and foster inclusivity. By showcasing the practical application of sign language interpretation, it highlights the transformative potential of innovative solutions in facilitating meaningful communication for individuals with diverse needs. Looking ahead, ongoing research and development efforts offer promising avenues for refining and advancing sign language interpretation systems, ultimately empowering individuals to participate fully in society regardless of their communication abilities.

Keywords Sign Language Recognition, Automatic Interpretation, Image Processing, Artificial Intelligence, Speech-to-Text Conversion

1. INTRODUCTION

In a world where communication is the cornerstone of connection, understanding, and progress, the ability to effectively convey thoughts and ideas transcends barriers. However, for the Deaf community, this fundamental aspect of human interaction has often been a challenge, as traditional methods of communication often fall short in facilitating seamless interaction between the Deaf and hearing worlds. Enter the Hand Sign to Text Converter, a groundbreaking innovation poised to revolutionize communication for the Deaf community.

Imagine a technology that can decode the intricate language of hand signs, transforming them into readily understandable text in real-time. This is precisely what the Hand Sign to Text Converter promises a transformative solution that holds the potential to bridge the gap between the Deaf and hearing communities like never before.

In this article, we delve into the significance of the Hand Sign to Text Converter, exploring its multifaceted impact on

communication, accessibility, education, and societal inclusion. From its origins to its practical applications, we unravel the layers of this innovation to understand how it is poised to shape a more equitable and inclusive future for all. Join us on this journey as we examine the profound implications of the Hand Sign to Text Converter and its role in redefining the landscape of communication for the Deaf community and beyond.

The Hand Sign to Text Converter aims to mitigate the challenges faced by deaf individuals in accessing information and services in environments where sign language interpreters may not be readily available. By providing a portable and efficient means of communication, it empowers individuals to navigate various situations independently.

The development of the Hand Sign to Text Converter aligns with broader societal efforts towards inclusivity and accessibility. As society increasingly recognizes the rights and needs of individuals with disabilities, innovative solutions like the converter play a crucial role in promoting equal opportunities and ensuring that no one is left behind.

BACKGROUND

The creation of the Hand Sign to Text Converter represents a pivotal moment in technological innovation, particularly in its application toward breaking down communication barriers for the deaf community. This groundbreaking solution emerged in response to the pressing need for effective communication tools tailored to individuals who primarily use sign language. Sign language has long served as a primary means of expression for deaf individuals, enabling them to convey thoughts, emotions, and ideas through hand gestures, facial expressions, and body movements. However, the lack of understanding of sign language among many individuals poses a significant obstacle to effective communication between deaf and hearing communities.

In response to this challenge, researchers and technologists have diligently worked to develop solutions that bridge the gap between sign language and spoken or written language. The Hand Sign to Text Converter embodies the culmination of these efforts, utilizing sophisticated image processing and artificial intelligence techniques to translate sign language gestures into written text in real-time. By harnessing the capabilities of technology, the converter facilitates seamless communication between deaf individuals and the wider community. It empowers deaf individuals to express themselves more freely and access information and services that were previously beyond reach due to communication barriers. Furthermore, by providing a means for others to understand and engage with sign language, the converter promotes inclusivity and fosters a more accessible and equitable society.

The development of the Hand Sign to Text Converter underscores the transformative potential of technology in meeting

the unique needs of diverse communities. As technology continues to advance, there exists significant opportunity for further innovation in this field, ultimately enhancing communication accessibility and empowering individuals of all abilities to fully participate in society.

Sr no	PAPER NAME	AUTHER	DESCRIPTION
1)	Recognition of Indian sign language in live video	Joyeeta Singha, Karen Das	Sign Language Recognition has emerged as one of the important area of research in Computer Vision. The difficulty faced by the researchers is that the instances of signs vary with both motion and appearance. It deals with bare hands, considered 24 different alphabets in the video sequences and attained a success rate of 96.25%.
2)	A Deep Learning Approach for Analyzing Video and Skeletal Features in Sign Language Recognition	D. Konstantinidis, K. Dimitropoulos and P. Daras	They propose a deep learning based framework, in which we examine and analyze the contribution of video and skeletal features in the challenging task of isolated SLR, in which each signed video corresponds to a single word.
3)	Design and Implementation of A Sign-to Speech/Text System for Deaf and Dumb People	Dalal Abdulla, Shahrazad Abdulla and Ramesa Manaf ,An war H. Jarndal	This paper presents an approach for designing and implementing a smart glove for deaf and dumb people. develop a sign to Arabic language translator based on smart glove interfaced wirelessly with microcontroller and text/voice presenting devices The whole system has been implemented, programmed, cased and tested with very good results.
4)	Human action recognition using deep neural networks	R. R. Koli and T. I. Bagban	Human activity recognition provides the platform to interact with the deaf and dumb person. Develop a platform for hand movement recognition by using the CNN
5)	Talking Hands – An Indian	S Yarisha Heeral,	In the proposed method, we will be

	Sign Language to Speech Translating Gloves	Madhuri K Murthy1, Sravanti V S1	using sensors which are incorporated on a glove to detect the gestures and convert it to speech with the help of a Bluetooth module and an Android Smart Phone. The gloves will help in producing artificial speech which provides an environment similar to daily communication which is hard to achieve for speech impaired people.
6)	Real-time Conversion of Sign Language to Text and Speech	Kohsheen Tiku, Jayshree Maloo, Aishwarya Ramesh, Indra R	This system is designed to enable deaf and mute people to communicate with others in a more accessible and convenient way. The proposed method uses computer vision and deep learning methods to recognize hand gestures and translate them into appropriate text.

MOTIVATION

The implementation of a Hand-to-Text Converter for Deaf communication was driven by a motivation to address long standing challenges and inequalities faced by the deaf community. At its core, this technology aims to level the playing field by ensuring communication equality for deaf individuals. It seeks to break down communication barriers, foster inclusivity, and empower deaf individuals in their interactions with the hearing world. Additionally, the Hand-to-Text Converter strives to enhance educational opportunities, create equal career prospects, and leverage cutting edge technological innovation to improve the lives of deaf individuals. By promoting stronger social connections, reducing isolation, and having the potential for a global impact, this technology embodies a commitment to creating a more equitable and inclusive society for all.

The motivation behind the development of the Hand Sign to Text Converter stems from the pressing need to address communication barriers faced by individuals within the deaf and hard of hearing community. These barriers often hinder effective communication between sign language users and those who do not understand sign language. By providing a means to translate sign language gestures into written text, the converter aims to break down these barriers and promote inclusivity and accessibility.

The motivation extends to empowering individuals within the deaf community by providing them with a tool that enhances their independence and autonomy. With the converter, deaf individuals can communicate more effectively in various settings, including educational, professional, and social environments, without the need for constant assistance from sign language interpreters.

There are various sign languages all over the world, namely American Sign Language (ASL), French Sign Language, British Sign Language (BSL), Indian Sign language, Japanese Sign Language and work has been done on other languages all round the world.

The development of the Hand Sign to Text Converter is driven by a broader societal commitment to inclusivity and accessibility for individuals with disabilities. By leveraging technology to create innovative solutions that address the unique needs of diverse communities, the converter aligns with the principles of equal opportunities and ensures that everyone, regardless of their communication abilities, can fully participate in society.

OBJECTIVE

The objective is to give them the ability to express ideas and thoughts. They can get help in increasing their motivation and confidence; it will help them to think positively and to conquer that physical disability. Using the latest technologies and tools, we aim to develop a system to overcome this global-level problem. By translating sign language gestures into written text, this innovative technology aims to bridge the gap between sign language users and those who do not understand sign language. The primary goal is to enable seamless communication in diverse settings, including educational, professional, and social environments. Additionally, the converter seeks to promote inclusivity by breaking down communication barriers and fostering greater understanding and empathy across all communities. With a focus on real-time translation, accuracy, and reliability, the converter aims to deliver precise interpretations of sign language gestures, ensuring that the intended message is conveyed effectively. Furthermore, the design prioritizes a user-friendly interface to ensure accessibility for individuals of all technological proficiencies. Ultimately, the objective of the Hand Sign to Text Converter is to empower individuals within the deaf community, enabling them to communicate confidently and participate fully in society.

2. MACHINE LEARNING ALGORITHMS

CNN A Convolutional Neural Network(ConvNet/ CNN) is a Deep literacy algorithm which can take in an input image, assign significance(learnable weights and impulses) to colourful aspects objects in the image and can be able to separate one from another. The preprocessing needed in a ConvNet is much lower as compared to other bracket algorithms. While in primitive styles pollutants are hand- finagled, with enough training, ConvNets have the capability to learn these pollutants characteristics. The armature of a ConvNet is similar to that of the connectivity pattern of Neurons in the mortal Brain and was inspired by the association of the Visual Cortex. Individual neurons respond to stimulants only in a confined region of the visual field known as the open Field. A collection of similar fields lap to cover the entire visual area.

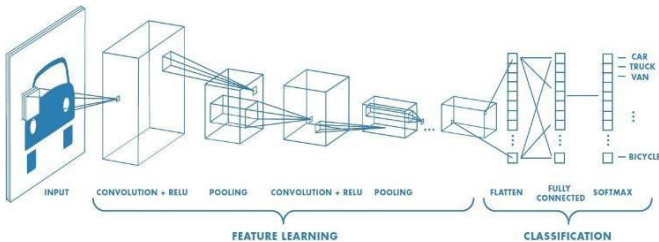

Figure 1 : Working of CNN

3. METHODOLOGY

1. Data Collection: Gather sign language data from various sources, such as video recordings or sign language databases. Ensure the data covers a wide range of signs and gestures to train the model effectively.
2. Preprocessing: Clean and normalize the data to remove noise, standardize formats, and prepare it for further processing. This step may include tasks like background removal, hand tracking, and image enhancement
3. Gesture Recognition: Train machine learning models, such as convolutional neural networks (CNNs) or recurrent neural networks (RNNs), to recognize signs from the pre-processed data. This involves mapping hand gestures to specific signs or words in the sign language.
4. Translation: Convert the recognized signs into text. This step may involve using a lookup table or a translation model to map signs to corresponding words or phrases in the target language.
5. User Interface: Develop a user-friendly interface that allows users to input sign language gestures, view the translated text, and receive feedback on plagiarism detection. The interface should be accessible and intuitive for users with varying levels of sign language proficiency.
6. Testing and Validation: Thoroughly test the system to ensure its accuracy, reliability, and usability. Validate the results against ground truth data and fine-tune the models as needed to improve performance.
7. Real-Time Processing: Optimize the system for real-time processing to provide immediate translation and feedback. This may involve optimizing algorithms, leveraging parallel processing, or using hardware acceleration.

4. SYSTEM ARCHITECTURE DIAGRAM

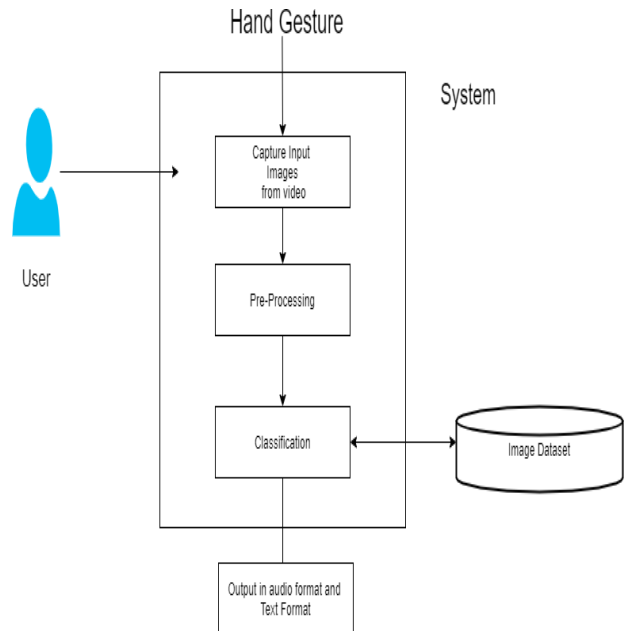

Figure 2 : System Architecture

First, the system needs to be able to recognize hand gestures, which involves understanding the movements of hands in a video. This step is crucial for accurately interpreting the signs being made .Next, the system captures images of the hand gestures from the video. These images serve as the input for further processing. After capturing the images, preprocessing is done to enhance their quality. This may

involve techniques like resizing the images, reducing noise, and improving clarity to make it easier to classify the gestures. The core of the system lies in classifying the gestures. Machine learning or deep learning models are used to analyse the pre-processed images and determine what each gesture means. This step requires a dataset of hand gesture images to train the classification model effectively. Lastly, once the gestures are classified, the system can output the results. This involves converting the recognized gestures into written words and spoken words, making it easier for people to understand and communicate using sign language.

SOFTWARE REQUIREMENTS:

- Operating System: Windows 10
- IDE: Spyder
- Programming Language: Python

HARDWARE REQUIREMENTS:

- Hardware: intel core
- Speed: 2.80 GHZ
- RAM: 8GB
- Hard Disk: 500 GB
- Keyboard and Camera : Integrated / External

5. RESULT

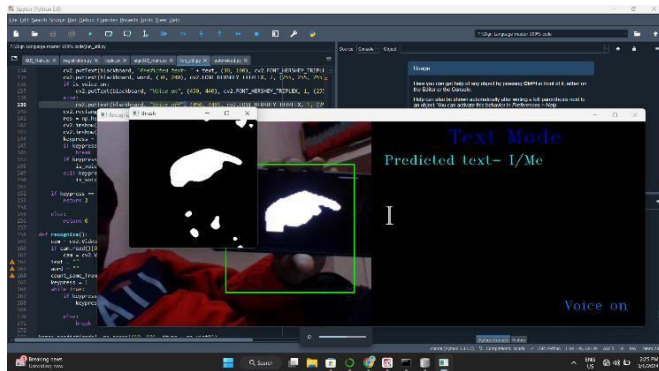

Figure 3(a) : Result 1

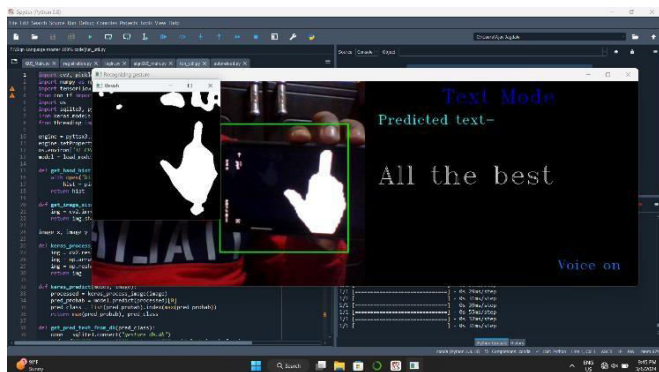

Figure 3(b) : Result 2

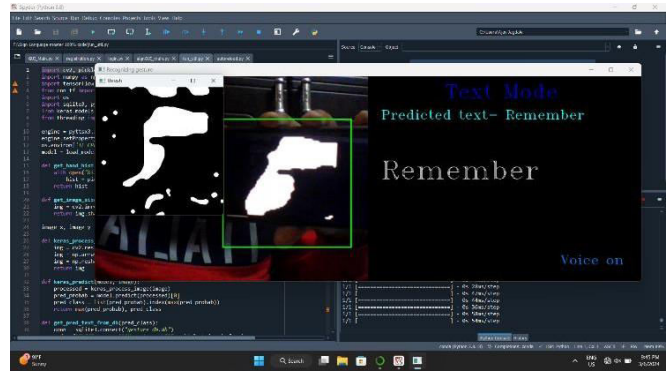

Figure 3(c) : Result 3

DESCRIPTION

The hand sign to text converter employs a multifaceted approach to accurately interpret sign language gestures and convert them into written text. Here's a steps of how it works:

1. **Hand Tracking :** The process begins with capturing the hand movements of the user through a camera or sensor system. Advanced computer vision algorithms are employed to track the position, orientation, and movement of the hands in real-time. This step is crucial for accurately interpreting the sign language gestures.
2. **Gesture Recognition :** Once the hand movements are tracked, the system analyzes them to identify specific sign language gestures. This involves comparing the observed hand configurations, movements, and spatial relationships to a pre-defined database of known sign language gestures. Machine learning techniques may be employed to improve the accuracy of gesture recognition over time.
3. **Semantic Interpretation :** After recognizing individual gestures, the system interprets their semantic meaning within the context of the conversation. This involves understanding the grammar, syntax, and semantics of the sign language being used. For example, the system may analyze the sequence of gestures to identify words, phrases, or sentences.
4. **Text Generation :** Based on the interpreted gestures and their semantic meaning, the system generates written text corresponding to the signed message. This text representation may include words, punctuation, and other linguistic elements necessary for conveying the intended message accurately.
5. **Output Display :** Finally, the converted text is displayed on a screen or transmitted through digital channels in real-time. Users can view the text output on a computer monitor, mobile device screen, or other display interfaces. Additionally, the system may support alternative output modalities such as speech synthesis for users with visual impairments.

6. CONCLUSION

Sign Language is a tool to reduce the communication gap between deaf/mute people and normal humans. The development of this sign language conversion system represents a significant advancement in bridging the communication gap for deaf and mute individuals. By providing real-time conversion of signs into speech, the system empowers these individuals to express themselves more effectively in various social and professional settings without the need for a human interpreter. The system proposed gives the methodology that aims to work the same way as two-way communication. The proposed method facilitates the conversion of signs into speech, overcoming the requirement of a translator because of real-time conversion. The system acts as the voice of the person who is deaf/mute. This project is a step towards helping specially challenged

people. We can enhance it by making it more user-friendly, efficient, portable, and compatible with many more gestures, as well as dynamic ones.

7. FUTURE SCOPE

In unborn work, proposed system can be developed and enforced using jeer Pi. Image Processing part should be bettered so that in unborn work, proposed system can be developed and enforced using jeer Pi. Image Processing part should be bettered so that System would be suitable to communicate in both directions i.e.it should be able of converting normal language to subscribe language and vice-versa. We'll try to fete signs which include stir. also, we will concentrate on converting the sequence of gestures into textbook i.e. word and rulings and also converting it into the speech which can be heard.

8. ACKNOWLEDGEMENT

It gives great pleasure to present the preliminary project report on the project topic, "Hand Sign to Text Converter." We take this opportunity to thank our internal guide, Dr. P. C. Latane, for giving us all the help and guidance we needed. We are grateful to him for his kind support. His valuable suggestions were quite helpful.

9. REFERENCES

- [1]. J. Singha and A. Karen Das, "Recognition of Indian Sign Language in Live Video," 2019, arXiv preprint arXiv:1306.1301.
- [2]. D. Konstantinidis, K. Dimitropoulos and P. Daras, "A deep learning approach for analyzing video and skeletal features in sign language recognition", 2018 IEEE international conference on imaging systems and techniques
- [3]. Dalal Abdulla, Shahrazad Abdulla and Ramesa Manaf ,An war H. Jarndal, " Design and implementation of a sign-to-speech/text system for deaf and dumb people" 2017 IEEE International Conference on Power
- [4]. R. R. Koli and T. I. Bagban, "Human action recognition using deep neural networks", 2020 Fourth World Conference on Smart Trends in Systems Security and Sustainability
- [5]. S Yarisaa Heera1, Madhuri K Murthy, Sravanthi V S1, " Talking Hands – An Indian Sign Language to Speech Translating Gloves", 2017 International Conference on Innovative Mechanisms for Industry Applications (ICIMIA), 10.1109/ICIMIA.2017.7975564
- [6]. Koshseen Tiku, Jayshree Maloo, Aishwarya Ramesh, Indra R, "Real-time Conversion of Sign Language to Text and Speech," 2020 Second International Conference on Inventive Research in Computing Applications, Coimbatore, India, 2020

Deep Learning Assisted Signature Verification System

Ashish A. Kulkarni

Department of Electronics & Telecommunications
PVPIT, Bavdhan, Pune, India
ashishak2303@gmail.com

Abstract— A signature is one of the key personal data attributes of an individual and acts as an important artifact for authentication on documents like bank cheques, passports, driving licenses, legal documents, etc. In this digital era, human interaction with machines has drastically increased giving rise to several means of biometric authentication however Signature - one of the initial biometric features used for authentication still retains its importance. With technological advent, verification of signature to prove identity has gone digital. Modern-age technology like Machine learning has significantly improved this process. Unforeseen situations like the COVID-19 pandemic have given rise to the need for a robust online system that enables an individual to prove their identity while being at home. This paper proposes an online system for Signature verification enabling individuals to provide signature through webcam and get verified online. The system uses Deep learning enabled through Convolutional Neural Networks (CNN) such as VGG-16 which offer multi-layered image recognition providing it capability to analyze the signature like a human expert. It's developed through Python and hosted on a lightweight web framework. The system uses Static verification techniques to train the model and verify the signature image against the anchor data.

Keywords—Deep Learning, Signature Verification, CNN, VGG16, Image Processing, TensorFlow, Streamlit

I. INTRODUCTION

A signature is a unique alphanumeric pattern that an individual draws on documents to prove self-identity. There could be an issue if someone counterfeits the signature of someone else to forge his/her identity. This can lead to financial, contractual, compliance, or legal disputes. Therefore, the verification of a hand-written signature to prove authenticity is a very important process in verifying someone's identity. In older days, Signature verification was done manually but using expert judgment which has gone digital now. Digital verification of Hand-written signatures can be done in 2 ways –

- Static : also referred to as the "offline" method in some literature
- Dynamic : also referred to as "Online" in many places.

In the Dynamic method, signatures are captured using touch-screen devices by detecting the strokes, pressure, speed variations, etc. while it's being done and records the associated features. These features are captured against the predefined database to achieve successful validation. In the static method, a paper-based handwritten signature is provided to the system through digital conversion using devices like scanners, and webcams. Such methods rely solely on the static features of the signature image for the verification process and hence related analysis is more complex than the Dynamic method. To satisfy the compliance norms, the Static method is widely used in most

of the territories. Situations like the COVID-19 pandemic necessitate such verification systems to enable usage remotely and without physical contact. A signature is categorized as sensitive personal data which needs such systems to provide additional authentication features and logical separation of signature data from external interaction thereby enhancing the security.

With the above background, the problem statement for this research work is -

- Provide a robust static signature verification system that enables remote and contactless capturing of data
- Accurate analysis of input data
- Enhanced data protection through logical separation

To explain the solution to the above problem statement, this paper is organized as follows: Section 2 details the Literature survey. Section 3 explains the proposed solution and methodology used. Section 4 provides the visualization of the outcome. Section 5 concludes the results while Section 6 puts forward the future scope in this area.

II. LITERATURE SURVEY

“Signature Verification Based on Deep Learning” by Wessam M. Salama et al. (2023)[1] – This work proposes the usage of Deep Learning Models (DLMs) in the area of Signature verifications. It details the popular DLMs like ResNet50, DenseNet121, MobileNetV3, InceptionV3, and VGG16 which can be used here. Using pre-trained models, it compares the performance of each of these models. This paper sets a foundation for the usage of DLMs in the area of signature verification by providing performance parameters and related comparison however lacks the actual implementation through a Signature verification system.

“Digital signature Forgery Detection using CNN” by Kiran, Lakkoju Chandra, et al. (2021)[2] - The author has outlined the importance of visual representation of artifacts in digital computing. Technological progression is introducing new opportunities for digital forgery and hence it's critical to verify the integrity of the digital images. The criticality further increases in areas like signature verification. The research work provides a robust mechanism to detect traces of possible forgery in digital images of handwritten signatures thereby improving the results.

“Handwritten Signature Verification using Deep Learning” by Alajrami, Eman, et al. (2019)[3] - This work highlights the importance of the signature in sensitive fields like legal documentation, banking, etc. for personal identification. It also details the classification of the methods used for signature verification i.e. Static and Dynamic. The proposed solution uses 2 level approach in the signature verification process - (i) template matching using Hidden-Markov model for signature comparison (ii) Forgery detection in the input image using Convolutional Neural

Networks. It also explains CNN operations such as convolution, max pooling, fully-connected layer, ReLu(Rectifier), and softmax. The work concludes by showcasing the highest accuracy using the split ratio of 8:2

"Offline Signature Recognition and Forgery Detection using Deep Learning" by **Poddar, Jivesh, et al. (2020)**[4]- This paper reemphasizes the importance of the signature verification process. This work also has proposed a dual method of signature recognition and forgery detection for enhanced outcomes. It is based on CNN(Convolutional Neural Network) for signature recognition with SURF and Harris corner detection algorithms used for forgery detection. In CNN, the signatures go through noise removal, scaling, centralization, and rotation. Whereas in the Crest-Through Method, the signatures go through length-to-space ratio, width-to-space ratio, and Crest-Through parameter. Both CNN and Crest-Through Methods are also used for signature recognition. Then, these signatures go through forgery detection. In forgery detection, the Harris corner detection algorithm is used to detect and extract corner points of the signature for comparison with the real signature. This gives valuable insights with some inherent flaws.

"Transfer learning using VGG16 with Deep Convolutional Neural Network for Classifying Images" by **Srikanth Tammina , et al. (2019)** - This work explains how data mining algorithms and machine learning algorithms are used to handle the problems under consideration in isolation. It also highlights the fact that in the Machine Learning world training and test data are assumed to have identical feature spaces with the underlying distribution however that's not the case in practice. The paper explains how trained VGG16 models with Deep Convolutional Neural Networks can be effectively used to classify images. It also highlights how multi-layered architecture of VGG16 model leads to enhanced accuracy. This gives insights and sets the basis for using VGG16 models effectively for Signature image verification.

Considerable research has been done by multiple data scientists in the area of handwritten signature analysis through pattern matching. Remarkable research has been done in the area of Static techniques for Signature verification still it remains widely un-explored. Due to the associated complexities, signature verification needs large datasets to attain higher accuracy. Most of the work to date has been done by converting Signature images in RGB format to Grayscale before performing verification. VGG16 model provides a greater ability to do so without grayscale conversion. In the research done so far, lesser attention has been given to the security of signature database by decoupling the data storage, model training, and verification modules. On-the-fly capturing of the paper-based signatures for verification also remains relatively unattended.

III. PROPOSED SOLUTION AND METHODOLOGY

This section details the proposed solution with its high-level building blocks along with associated responsibilities as conceptual architecture. It further explains the methodology as a process flow along with the operation of individual modules.

A. Solution Architecture

The block diagram in *Fig 1* shows the high-level design of the proposed solution. The said architecture will enable

basic user validation and capturing of the signature to initiate the verification process. The data store will contain the large set of signature classes used to train the model. The image processing module will take care of image preprocessing, feature extraction[4], and feature comparison. The system will use the CNN model used for signature verification. Finally, the user will be presented with the outcome of the verification process on the user interface.

Details of the solution blocks are as below –

1) *User Interface (UI)* - The user interface will be deployed as a web page (local-hosting for demonstration) developed using Python programming language and deployed

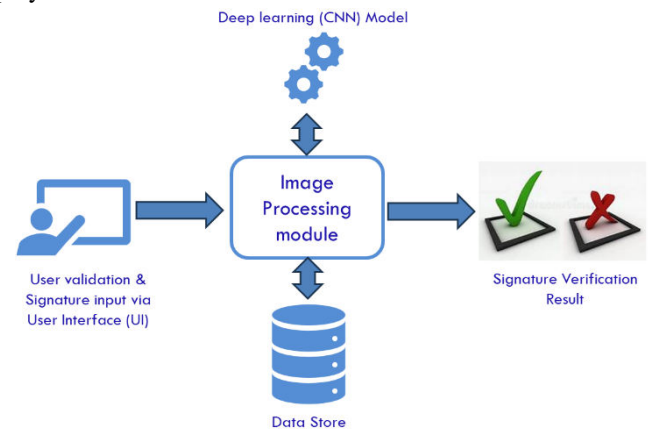

Fig. 1 – Solution Architecture

on the lightweight Streamlit framework. UI will perform the basic user validation and enable the user to interactively capture the image of a paper-based handwritten signature for verification using a Webcam. Once the verification process is completed, the verification results will be displayed on the same UI. UI will offer a simplified page for users to interact with.

2) *Data store* - The data store (hosted on the Windows file system) will contain the classes of signature images with multiple samples for both genuine and forged signatures. Features extracted from the data set will be used to train and test the CNN model. A Set of genuine images from each class will serve as an anchor to compare the test image. The data store will ensure direct integration with all the modules except UI to enable logical data separation thereby enhancing the security.

3) *Image processing Module* - The image processing module is developed in Python programming language and deployed as an independent executable. This will take care of image pre-processing, captured image storage to data store, image verification, and image rendering on UI. It will also enable logical partitioning of the verification and model training process.

4) *Deep Learning Model* - This will consist of a Python module to extract features from pre-processed images, train the model, and save it as a reference model (on file system) to orchestrate the verification process. This solution will use a CNN model based on VGG16 architecture. VGG16 is a popular model based on Convolutional Neural Network (CNN) proposed by K. Simonyan and A. Zisserman

(University of Oxford) in their paper “Very Deep Convolutional Networks for Large-Scale Image Recognition”. It is one of the significant models submitted to

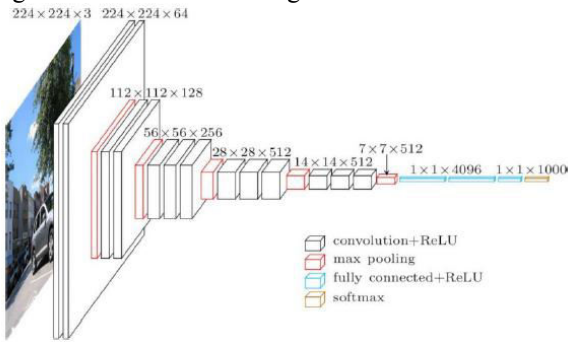

Fig 2 – VGG16 architecture

ILSVRC-2014. It can be looked at as an improvement over AlexNet by replacing large kernel-sized filters with multiple 3x3 kernel-sized filters one after another. Its architecture is as shown in Fig. 2

B. Methodology

This section explains the methodology used for end-to-end processing of Signature image(s) through the solution to get the "Signature Verification Result" as an outcome. The initial few steps are to process the data set to build the reference model while the rest take care of the signature verification. The detailed process flow is shown in Fig 3. Further details on each of these steps as below -

- *Define dataset:* A dataset containing genuine and fake signature images is organized and defined on the file system. Samples for each user are categorized into classes with a unique identification number assigned to each class. For demonstration purposes, we have used "Social Security Number" (Aadhar Number in the Indian context) as the unique identifier (considering it unique for each individual). The entire class is used for training and testing

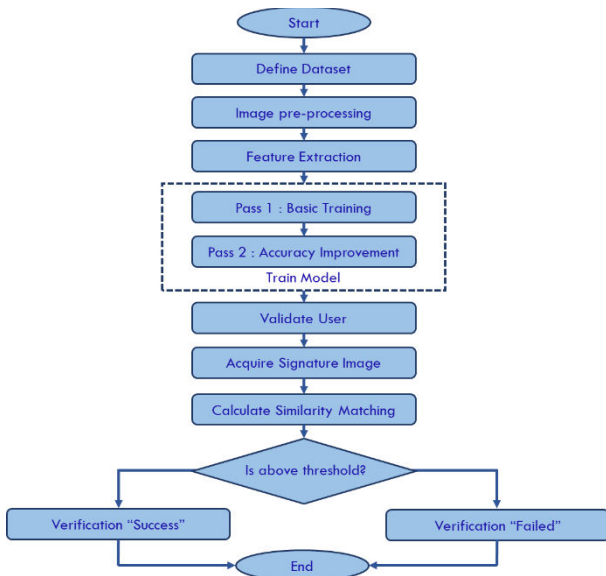

Fig. 3 – Process flow

the model while the genuine samples in each class serve as an anchor during image verification. We have used a

dataset from Kaggle containing 70 classes each containing 24 genuine and 8 fake signatures.

- *Image Pre-processing:* For feature extraction during training as well as verification, we need to resize and normalize the image while retaining its aspect ratio. The step takes care of both activities. For this work, it's achieved using code developed in Python programming language using image preprocessing utilities in Keras framework[5]
- *Feature extraction:* This step takes care of extracting the features of the defined training and testing dataset. For the system under consideration, features are extracted using code developed in Python language.
- *Train model:* In this step, the features extracted above are used to train and test the model. The model used here is a CNN based on VGG16[6] architecture. It ensures the analysis of features at multiple layers of the Image. The model utilizes a Stochastic Gradient Descent (SGD) optimizer[7] for improved performance. The model is defined, trained, compiled, tested, and saved using the TensorFlow platform using Python programming language[5]. This application uses model training with 2 passes to improve accuracy. 1) Pass 1 - Freezing original layers 2) Finetuning with all layers set trainable. The training and tested model is saved on the file system as a reference for the signature verification.
- *Validate user:* With the trained model available, the system is ready to start its "Signature Verification venture". System UI will take care of capturing basic details such as name, and Aadhar number to validate the user. Validation with Aadhar will also facilitate the identification of anchor images for signature comparison. The anchor image set will be copied to separate working space for logical data separation as well as to speed up the matching processes.
- *Acquire Image:* With user validation, the feature will be enabled to capture the handwritten signature image using a Webcam. The associated code is developed in Python programming language for faster processing. The captured image will again undergo pre-processing (same as step 2) before it is presented for matching. This ensures the best quality image is presented for matching process.
- *Perform matching:* At this stage captured test image features are matched against extracted features (based on the trained model) for all the anchor images available. Considering multi-layered processing in VGG16, Cosine similarity[8] between the features will be used as a measure to define the level of matching between test & anchor image features. This measure addresses the parameters like natural tilt in handwritten signatures, uneven surfaces, etc. Feature extraction is done using the TensorFlow platform while Cosine similarity is calculated using the Scikit-learn package in Python programming language.
- *Comparison with threshold:* The outcome of the matching process is a similarity score on a scale of 0 to 1. This score is compared against a predefined threshold to mark the success or failure of the

verification process. The outcome is displayed as a verification result on the UI.

C. Equations

Stochastic Gradient Descent (SGD) between data sample $x^{(i)}$ and data label $y^{(i)}$ is given by below equation.

$$\theta = \theta - \eta \cdot \nabla_{\theta} J(\theta; x^{(i+n)}; y^{(i+n)}) \tag{1}$$

Cosine Similarity between 2 vectors A and B is given by equation below –

$$similarity(A, B) = \cos(\theta) = \frac{A \cdot B}{\|A\| \|B\|} \tag{2}$$

IV. RESULTS

Results have been included here to show the effectiveness of the system under consideration while implemented in practice. Experimental results obtained through training of the model using 40 classes (as shown in Fig 4) show significant improvement in the accuracy with increasing epochs. It significantly improves over the second pass of model training. This can be observed in the graph depicted in Fig 5.

Results also show the actual User Interface (UI) deployed for the said system. Fig 6 shows the image getting successfully captured through the webcam while Fig 7 and 8 show the signature verification results for the success and failure cases.

```

Dataset loading
Found 605 images belonging to 40 classes.

At end of Pass-1
Epoch 23/25
19/19 [*****] - 198s 11s/step - loss: 2.3010 - accuracy: 0.4446 - val_loss: 2.0466 - val_accuracy: 0.5107
Epoch 24/25
19/19 [*****] - 202s 11s/step - loss: 2.2404 - accuracy: 0.4595 - val_loss: 2.0382 - val_accuracy: 0.4678
Epoch 25/25
19/19 [*****] - 202s 11s/step - loss: 2.2359 - accuracy: 0.4461 - val_loss: 1.9972 - val_accuracy: 0.5199

At end of Pass-2
Epoch 8/10
19/19 [*****] - 460s 24s/step - loss: 0.1836 - accuracy: 0.9504 - val_loss: 0.1220 - val_accuracy: 0.962
Epoch 9/10
19/19 [*****] - 462s 25s/step - loss: 0.1739 - accuracy: 0.9388 - val_loss: 0.0893 - val_accuracy: 0.976
Epoch 10/10
19/19 [*****] - 457s 24s/step - loss: 0.1374 - accuracy: 0.9584 - val_loss: 0.1218 - val_accuracy: 0.963
    
```

.Fig 4 – Accuracy at end of Pass-1 and Pass-2

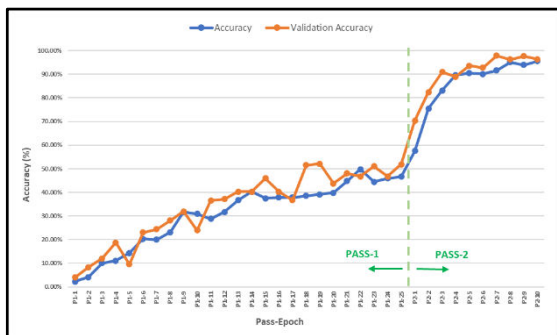

Fig 5 – Accuracy Variations

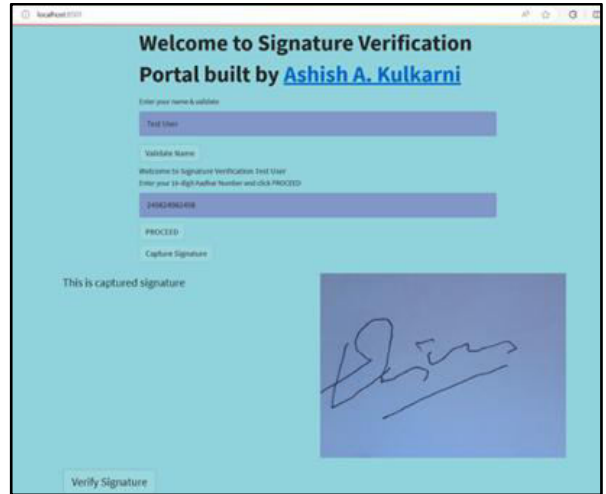

Fig 6 – UI with Image captured post User validated

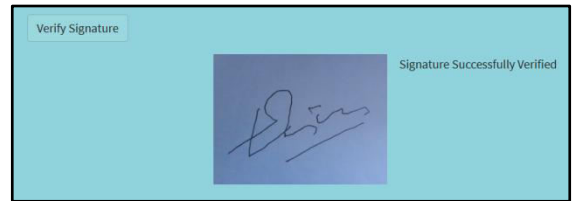

Fig 7 – Successful Verification

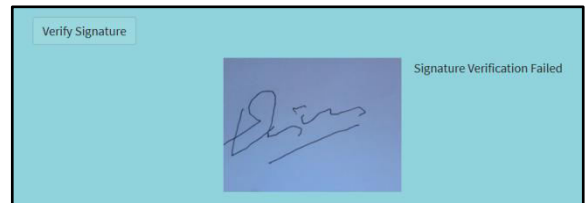

Fig 8 – Failed Verification

V. CONCLUSION

Model in the system under consideration trained using 40 classes (containing 605 images) gives accuracy up to 95.5%. moreover, the accuracy is observed to be significantly increasing with the 2-pass approach adopted in the model. The trained model has shown considerable capabilities for signature verification with accurate results. This highlights -

Effectiveness of the models based on Convolutional Neural Networks (CNNs) in the space of Signature analysis and verification. Signature verification can be conducted accurately for RGB images with VGG16 architectures using SGD Optimizer. Cosine Similarity is an effective mechanism for comparing the Signature image features

Paper-based handwritten signatures can be effectively captured and compared using a Webcam leading to successful Signature verification.

VI. FUTURE SCOPE

While this work shows satisfactory results for Signature Verification through the use of the 2-Pass Model trained with VGG16 architecture, the outcome can be further improved by taking up the below enhancements -

- Introducing noise removal in input images using Generative Adversarial Network (GAN) architecture can lead to more accurate verification

- Speed of matching can be improved using a 3-tier architecture with Web Interface, Model training, and Matching deployed on separate hardware
- Data security and training speed can be improved by deploying data store on mongoDB + GridFS configuration
- The accuracy of the model can further be improved by introducing continuous training (model trained on a regular basis with increasing data)

REFERENCES

- [1] Samar A. Kandeil, El-Sayed M.E. Mostafa, Wessam M. Salama, "Signature Verification Based on Deep Learning", *Alexandria Journal of Science and Technology(AJST)*, Online ISSN: 2974-3273, December 2023, 1(2), pp. 55–63
- [2] Lakkoju Chandra Kiran, Gorantla Akhil Chowdary, Manchala Shalem Raju, Kondaveeti Gopi Krishna, "Digital signature Forgery Detection using CNN", *International Research Journal of Engineering and Technology (IRJET)*, e-ISSN: 2395-0056, Volume: 08 Issue: 06 | June 2021,
- [3] Eman Alajrami, Belal A. M. Ashqar, Bassem S. Abu-Nasser, Ahmed J. Khalil, Musleh M. Musleh, Alaa M. Barhoom et. al., "Handwritten Signature Verification using Deep Learning", *International Journal of Academic Multidisciplinary Research (IJAMR)*, ISSN: 2643-9670, Vol. 3 Issue 12, December – 2019, pp. 39-44
- [4] Jivesh Poddara, Vinanti Parikha, Santosh Kumar Bhartia, "Offline Signature Recognition and Forgery Detection using Deep Learning", *The 3rd International Conference on Emerging Data and Industry 4.0 (EDI40)*, April 6 - 9, 2020, Warsaw, Poland, ScienceDirect Procedia Computer Science 170 (2020) 610–617
- [5] B.Akhila, G.Nikhila, A Lakshmi, G.Jahnavi, Mrs .J.Himabindhu, "Signature Verification Using Image Processing and Neural Networks", *IJCRT | Volume 9, Issue 8 August 2021 | ISSN: 2320-2882*
- [6] Aurélien Géron, "Hands-on Machine Learning with Scikit-Learn, Keras, and TensorFlow Concepts, Tools, and Techniques to Build Intelligent Systems", O'Reilly Media, Inc., Second Edition, June 2019, pp. 277-322, 367-478.
- [7] Imen Chebbi, "VGG16: Visual Generation of Relevant Natural Language Questions from Radiology Images for Anomaly Detection", *CLEF 2021 – Conference and Labs of the Evaluation Forum*, September 21–24, 2021, Bucharest, Romania.
- [8] Sebastian Ruder, "An overview of gradient descent optimization algorithms", arXiv:1609.04747v2 [cs.LG] 15 Jun 2017
- [9] Edel Garcia, "Cosine Similarity Tutorial", Published: 04-10-2015; Updated:08-26-2018, https://www.researchgate.net/publication/327248753_Cosine_Similarity_Tutorial.

Embedded System Based Medicine Assistant and Dispenser Powered By AI

Aarti Salunke
Assistant Professor
dept. Electronics and Computer
Engineering
Jawaharlal Nehru Engineering College
Chhatrapati Sambhajnagar, India
asalunke@mgmu.ac.in

Piyush Pachare
dept. Electronics and Computer
Engineering
Jawaharlal Nehru Engineering College
Chhatrapati Sambhajnagar, India
piyushpacharejnc@gmail.com

Guddu Gupta
dept. Electronics and Computer
Engineering
Jawaharlal Nehru Engineering College
Chhatrapati Sambhajnagar, India
guddujnc@gmail.com

Aditya Tayade
dept. Electronics and Computer
Engineering
Jawaharlal Nehru Engineering College
Chhatrapati Sambhajnagar, India
aadityajnc0008@gmail.com

Abstract—Accessibility to basic healthcare is fundamental for community development globally. This paper introduces an innovative machine leveraging artificial intelligence (AI) to tackle healthcare provision challenges in regions where establishing traditional medical facilities is arduous. This device represents a paradigm shift in healthcare delivery, ensuring simplicity and user-friendliness. Its intuitive interface empowers users, even those with limited technical knowledge, to browse and select from a diverse range of medications, a critical feature for remote regions with limited access to medicines.

Upon selecting a medication, the machine guides users through a secure payment process, eliminating the need for physical cash transactions and promoting hygiene. State-of-the-art technology verifies payment amounts, ensuring accuracy and reliability in dispensing medications, thus enhancing transparency and minimizing errors.

Through AI integration, the machine comprehends user symptoms via sensors and questions, suggesting appropriate medicines. This transformative tool amalgamates technology, accessibility, and affordability, offering hope to communities with limited healthcare access. Its deployment harbours the potential to significantly enhance health outcomes, serving as a beacon of progress in healthcare provision. This innovative approach addresses not only the logistical challenges of healthcare Delivery to remote regions. But also, the socio-economic barriers that impede access to essential medical services, ultimately contributing to the overall well-being and development of communities worldwide.

Index Terms— Arduino board, LCD Screen, Medicine, AI chatbot, Medication Dispensing, physical cash transaction, GSM module Arduino, user-friendly interface.

I. INTRODUCTION

The medicine dispensing machine strives to offer essential medical accessibility to unreachable places, bridging gaps caused by various factors. These factors include:

- Emergency situations: Immediate access to medications during accidents or sudden illnesses
- Convenience: Access to medications at any time, especially for people in remote areas or with busy schedules

- Confidentiality: Transactions are managed with utmost confidentiality sidestepping face-to-face interaction, to maintain confidentiality.
- Reduce overcrowding: Alleviate congestion in traditional pharmacies during peak hours
- Cost savings: More cost-effective than physical pharmacy locations, potentially leading to lower medication prices
- Remote healthcare support: Complement existing services in underserved areas, providing basic medications and healthcare products

The automated medicine dispensing system facilitates the distribution of over-the-counter (OTC) medications upon receipt of payment for the requested dosage. Designed for near-autonomous operation, the system features preset pricing and utilizes an image processing unit to authenticate customer payments. This autonomy streamlines operations, necessitating human intervention solely for restocking medication or cash reserves.

Furthermore, advancements in artificial intelligence (AI) integration are poised to enhance the system's capabilities. Leveraging sensors and a series of structured inquiries, AI algorithms will soon offer personalized medication recommendations tailored to individual needs and symptoms. This evolution promises to revolutionize the dispensing process, optimizing both efficiency and patient care.

II. RELATED WORK

Various actions had been taken to integrate technology into healthcare systems, particularly in the sector of medicine dispensing and management. This part check-up related works in the sector of embedded systems and AI-powered healthcare devices.

A. Automated Medicine Dispensing Systems

Automated medicine dispensing systems have been developed to improve medication adherence and reduce errors in dispensing. Systems like the MedReady automated dispenser [1] and the Philips Automated Medication Dispensing Service [2] use programmable interfaces to dispense medications at scheduled times. While these systems

offer convenience, they lack the intelligent decision-making capabilities of AI-powered systems.

B. AI-Powered Healthcare Assistants

AI-powered healthcare assistants, such as ADA Health and Babylon Health, provide personalized health information and recommendations based on user input. These systems make use of machine learning algorithms to analyse symptoms and suggest appropriate actions, including medication recommendations. While these assistants excel in providing general health advice, they lack direct integration with medication dispensing systems.

C. Integration of AI and Embedded Systems

Several projects have integrated AI with embedded systems to enhance healthcare services. For example, the MediPulse system [3] combines an embedded device for vital sign monitoring with AI algorithms for early detection of health issues. Similarly, the AIoMT (AI in Medicine and Healthcare) framework [4] provides a foundation for integrating AI capabilities into existing medical devices. These projects demonstrate the potential for AI-powered embedded systems to improve healthcare delivery.

D. Gap in Existing Literature

While existing systems address aspects of medication dispensing and AI-driven healthcare, there is a gap in the integration of AI with embedded systems for medication assistance and dispensing. The proposed system aims to fill this gap by providing an autonomous medication dispensing solution that leverages AI for personalized medication recommendations based on user input.

III. EMBEDDED SYSTEM BASED MEDICINE ASSISTANT AND DISPENSER POWERED BY AI

An embedded system-based medicine assistant and dispenser powered by AI can revolutionize healthcare accessibility, particularly in rural areas [5]. It can offer quick and quality healthcare services to users by providing sanitation facilities, symptom screening for various illnesses, and integrating an AI chatbot for health advice [6]. The system will be placed in schools, colleges, and public transportation hubs, ensuring easy access to healthcare services. Additionally, it will give proper medicine recommendations based on user input. The advantage of this system lies in its power-efficient design, allowing it to operate 24x7 [7]. Installing such a system in these locations can ensure instant healthcare services, benefiting students, commuters, and the general public who are unable or reluctant to visit traditional healthcare facilities.

IV. IMPLEMENTATION

The medication dispensing system is a sophisticated amalgamation of meticulously engineered components aimed at efficiently gathering patient input on symptoms and general health information. At its core are the Microcontroller and Microprocessor, represented respectively by the Raspberry Pi and Arduino UNO. These components are intricately designed to adeptly process commands, ensuring smooth operation of the system.

A pivotal feature of the system is its interactive touchscreen display, facilitating seamless patient consultation.

Through this interface, users can easily input their health information and receive tailored medication recommendations. Precision motors further enhance the system's functionality by ensuring accurate medication dispensation, guaranteeing precise dosages for patients.

In addition to its hardware components, the system incorporates a cloud-based database, seamlessly integrated to meticulously catalogue medication data. This database enables healthcare providers to access comprehensive patient information and make informed decisions regarding medication management. Moreover, it allows for the generation of personalized medication regimens tailored to individual patient needs.

An intuitive graphical user interface (GUI) displayed on the touchscreen enhances patient accessibility to a myriad of essential services. This user-friendly interface simplifies navigation and ensures that patients can easily access the features and functionalities of the system without encountering any usability issues.

Overall, the medication dispensing system represents a cutting-edge solution in healthcare technology, leveraging advanced components and innovative design to improve patient care and medication management processes. Its comprehensive features and intuitive interface make it a valuable asset in modern healthcare settings, promising enhanced efficiency and patient satisfaction.

A. Components and Implementation Strategies

a) Microcontroller (Raspberry Pi): The Raspberry Pi is like the brain of the system. It manages different parts of the system and can handle complex tasks, such as collecting patient information, suggesting medicines, and interacting with the database. It can also easily connect with other hardware, making the system work well together.

b) Microprocessor (Arduino UNO): The Arduino UNO works with the Raspberry Pi to control important tasks like dispensing medicines. It can quickly respond to sensors and controls, ensuring medicines are given accurately and on time. Its reliability and ease of use are crucial for the system to work smoothly.

c) Sensor: A non-contact thermometer to check the patient's body temperature. This thermometer allows for accurate temperature readings without physical contact, ensuring patient comfort and hygiene. Additionally, the system includes an oximeter (SpO2 sensor) to measure the patient's oxygen levels. These sensors help monitor patients' health more accurately, providing valuable information for medication recommendations and monitoring. The temperature and oxygen level data gathered is then used to provide precise medication recommendations and monitor the patient's health status.

d) Interactive Touchscreen Display and Graphical Interface(GUI): The interactive touchscreen display, featuring a user-friendly graphical interface, simplifies patient interaction by allowing easy input of symptoms and health information. It also presents medicine suggestions and other pertinent details, enhancing the overall user experience and accessibility for patients of varying technical abilities.

e) Precision Motors: These motors are used to dispense medicines accurately. They are programmed to give the exact amount of medicine as suggested by the system. This

accuracy is important for patient safety and effective treatment.

f) *Cloud-Based Database*: The database stores patient information, medicine data, and other important details. It allows healthcare providers to access patient records from anywhere, helping them make informed decisions about treatment. The cloud-based system also allows for the storage of large amounts of data securely.

g) *Artificial Intelligence (AI)*: AI algorithms are used to analyze patient input, such as symptoms and general health information, to generate personalized medication recommendations. These algorithms are designed to adapt and improve over time, providing more accurate and effective recommendations based on user feedback and new data. AI also plays a role in optimizing medication dispensation, ensuring that patients receive the right medications.

h) *Machine Learning (ML)*: ML algorithms are employed to continuously improve the system's medication recommendation capabilities. By analyzing patterns in patient data and medication outcomes, ML algorithms can identify trends and refine their recommendations to enhance patient outcomes. ML also enables the system to adapt to new medications and treatment protocols, ensuring that it remains up-to-date with the latest medical advancements.

B. Advanced Techniques and Algorithms

a) Natural Language Processing (NLP) Techniques:

- *Tokenization*: Essential for breaking down user inputs into individual words or phrases, facilitating analysis and understanding of symptoms.
- *Named Entity Recognition (NER)*: Crucial for identifying and extracting relevant entities like symptoms and diseases from user inputs, aiding the chatbot in understanding key components of the query.
- *Word Embeddings*: Utilized to represent symptoms, diseases, and medications as dense vector representations, capturing semantic similarities and relationships for better contextual understanding.
- *Intent Recognition*: Important for discerning the purpose behind the user's query, enabling the chatbot to provide appropriate responses based on user intent.
- *Contextual Understanding*: Leverages information from previous interactions to maintain coherence in conversations and offer personalized recommendations based on user history and preferences.

b) Machine Learning (ML) Module and Algorithms:

- *Decision Tree Algorithm*: Chosen for its interpretability and ability to capture complex relationships between symptoms, diseases, and medications, facilitating transparent decision-making in symptom classification and medication recommendation.
- *Gradient Boosting Machines (GBM)*: Employed to capture intricate relationships between symptoms, diseases, and medications,

achieving high predictive accuracy by combining the predictions of multiple models in a sequential manner.

c) *AI Algorithms*: Combination of Rule-based Logic and ML Algorithms: Integrating rule-based logic for transparent, guideline-compliant recommendations with ML algorithms for capturing complex relationships and providing personalized recommendations based on user-specific symptoms, disease characteristics, and demographics.

This ensures that the medicine recommendation chatbot remains equipped to effectively understand user inputs, identify relevant symptoms and diseases, and provide accurate and personalized medication recommendations.[9]

V. SYSTEM WORKFLOW

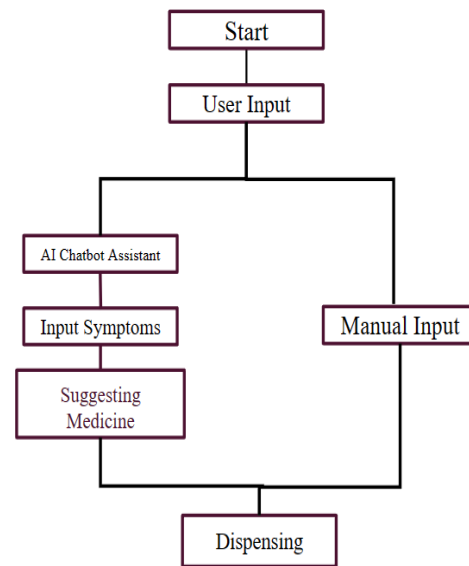

1) *Start*: This phase marks the initiation point of the process, where the user engages with the AI Chatbot Assistant to address their medical concerns.

2) *User Input*: At this stage, the user provides initial information regarding their symptoms or medical needs, initiating the interaction with the AI system.

3) *AI Chatbot Assistant*: This block represents the AI system responsible for interacting with the user. It aids in understanding the problem through a series of questions, processing the input to suggest appropriate medicine or treatments.

4) *Input Symptoms*: Users input their symptoms into the chatbot, enabling the AI to analyze and provide relevant medical guidance.

5) *Suggesting Medicine*: Based on the symptoms provided, the AI suggests suitable medicines or treatments to address the user's health issues effectively.

6) *Manual Input*: This essential step involves additional data entry or interaction, where users may directly input specific details such as the name of the medicine required, or other items like cotton and bandages.

7) *Dispensing*: The final step of the process involves the delivery of the suggested medicine or other first aid items to

the user, completing the interaction and addressing their medical needs.

VI. CONCLUSION AND FUTURE WORKS

In conclusion, our project has created a smart medicine dispenser that suggests and provides basic medicines based on what users tell it about their symptoms. This system is designed to help people in places where getting simple medicines is not easy. By using this machine, people can get the right medicines quickly and easily. We have shown that using artificial intelligence (AI) in this way can make healthcare more accessible and efficient.

Looking ahead, we plan to enhance our system in several ways. Firstly, we aim to improve the AI's accuracy in medicine recommendations by refining its algorithms and incorporating more extensive medical databases. Additionally, we intend to expand the system's capabilities to include a broader range of healthcare services, such as incorporating various medical kits for monitoring blood pressure, sugar levels, etc.

Furthermore, we plan to add an SOS calling feature to enable users to quickly contact hospitals in emergencies. We also aim to implement a feedback system to gather user input and continuously improve our system based on real-world usage.

By continually innovating and improving our system, we aim to make healthcare more accessible and convenient for everyone, regardless of their location or circumstances. Our ultimate goal is to positively impact healthcare outcomes and enhance the quality of life for individuals worldwide.

ACKNOWLEDGMENT

We acknowledge the collective efforts and expertise that have contributed to the conceptualization of the Embedded System based Medicine Assistant and Dispenser powered by AI. This work reflects the collaborative spirit and dedication of the research community towards advancing healthcare solutions. The transformative potential of AI technology in personalized medicine is central to our vision for this project.

REFERENCES

- [1] MedReady Automated Dispenser. Available online: [Medready Medication Dispenser | Automatic Pill Dispenser with Alarm (medreadyinc.net)]
- [2] Philips Automated Medication Dispensing Service. Available online: [Medication dispenser & connected apps | Philips Healthcare]
- [3] Smith, J. et al. (2019). MediPulse: An Embedded System for Remote Health Monitoring. *IEEE Transactions on Biomedical Engineering*, 66(8), 2250-2259.
- [4] Chen, L. et al. (2020). AIoMT: An AI-Driven Framework for the Internet of Medical Things. *Journal of Healthcare Engineering*, 2020, 1-10.
- [5] Eric Topol - "Deep Medicine: How Artificial Intelligence Can Make Healthcare Human Again"
- [6] John A. Stankovic - "Wireless Sensor Networks for Healthcare Applications"
- [7] Articles from journals like "IEEE Transactions on Biomedical Engineering" or "Journal of Medical Internet Research"
- [8] D. Ganesh, G. Seshadri, S. Sokkanarayanan, P. Bose, S. Rajan, and M. Sathiyarayanan, "Method and automated health machine for providing healthcare services to patients using iot," Patent 202 041 047 240,2020.
- [9] IBM WATSONX AI & ML Chatbot Building platform <https://www.ibm.com/topics/chatbots>.

Hybrid Energy inspired DC Micro-grid System using Machine Learning

Samruddhi Khairnar, Balasaheb Tarle, Sakshi Jadhav, Kunika Narnaware, Pranjal Shewale
Department of Computer Engineering, MVPS's KBT College of Engineering, Nashik-422013, India
kbtug20170@kbtcoe.org, tarle.balasaheb@kbtcoe.org

Abstract—Traditional power plants make use of the manual demand and generation matching processes, causing time delays and wastage of electric power. Hence, a smart hybrid power plant management system is necessary, to minimize the wastage of electricity by controlling the integration of various energy sources, according to the observed power demand of the users. In this paper, an LSTM-based machine learning approach for energy demand forecasting is discussed, including model architecture, hyper-parameter tuning, evaluation details. The mean squared error of the trained model is 0.0053 on load demand data from the Dataset-of-HRP-38-test-system by Zhenyu Zhou [4] and 0.0013 on data collected from a simulated fan load. These reliable estimates can be made use of by hybrid powerplants to control the generation of electric power according to the estimated demand. Further, a naive algorithm for power scheduling is explored.

Index Terms—Energy Demand Forecasting, Hybrid Power plant Controller, Energy Management System, Internet of Things, Machine Learning.

I. INTRODUCTION

The installed capacity of thermal power in India is 237.26 GW, accounting for 60 % of the total electricity generation in India [3]. The rest of which is derived from non-renewable energy sources. 64 % of the consumers are located in rural areas, where renewable energy is abundant from biomass, wind, etc. These resources can be integrated with the main grid as per their availability, beyond which, electricity can be generated as per the estimated load demand of the users, conventionally, aiming to minimize the reliance on the conventional energy sources.

In the study by Liu et al. [1], the authors investigate the impact of distributed energy resources (DERs) on traditional power plants and dispatch control centers. They introduce a simplified LSTM algorithm for one day-ahead solar power forecasting, achieving an average RMSE of 0.512. The authors made use of data collected from PhotoVoltaic (PV) systems to train models to forecast one day-ahead solar power generation.

The study by Shibl et al. [2] proposes a two-stage machine learning based energy dispatch management system for hybrid power plants (HPPs), aiming to optimize renewable energy integration alongside backup sources. The first stage aims to forecast the output power of renewable energy sources, as well as the load demand. The second stage aims at coordinating the output power of the reserve and backup sources.

II. MODEL ARCHITECTURE

A. LSTM Overview

Long Short Term Memory is a type of Recurrent Neural Network (RNN), used for learning sequences and time series data. It resolves the vanishing gradient issue of traditional RNNs. LSTM networks have cells that can store information over long time periods, allowing them to learn and remember patterns in time series data. These cells have an internal cell state and three gates (forget, input, and output gates).

$$f_t = \sigma(W_f \cdot [h_{t-1}, x_t] + b_f)$$

1. **Forget Gate** (f_t): Enables an LSTM cell to selectively forget a certain amount of previously stored information

$$i_t = \sigma(W_i \cdot [h_{t-1}, x_t] + b_i)$$

2. **Input Gate** (i_t): Enables an LSTM cell to selectively add new information at each time step.

$$\tilde{C}_t = \tanh(W_C \cdot [h_{t-1}, x_t] + b_C)$$

3. **Candidate Cell State** (\tilde{C}_t): It is the proposed update to the cell state at a given time step, calculated using the current input and the previous hidden state (output).

$$C_t = f_t \cdot C_{t-1} + i_t \cdot \tilde{C}_t$$

4. **Cell State** (C_t): Represents the long-term memory of the LSTM cell, allowing it to retain information over long sequences.

$$o_t = \sigma(W_o \cdot [h_{t-1}, x_t] + b_o)$$

5. **Output Gate** (o_t): Determines what should be the output of the LSTM cell at any given time step.

$$h_t = o_t \cdot \tanh(C_t)$$

6. **Hidden State** (h_t): Captures the information learnt by an LSTM cell at a specific time step, as its current output.

- \tilde{C}_t, C_t, h_t are the candidate, cell, and hidden states
- x_t is the incoming input at time step t
- W_f, W_i, W_C, W_o are weight matrices of the respective gates
- b_f, b_i, b_C, b_o are bias vectors used by the gates
- \tanh, σ are the hyperbolic tan, sigmoid activation functions
- $\tanh(z) = \frac{e^z - e^{-z}}{e^z + e^{-z}}$ and $\sigma(z) = \frac{1}{1 + e^{-z}}$

B. Data Preprocessing

The load demand data for compiling the model architecture was procured from the Dataset-of-HRP-38-test-system by Z. Zhou [4]. The load demand data was present in the form of hourly reading columns, which were flattened into a 1-D array of 8760 readings, followed by using a rolling window approach to generate a supervised learning dataset for LSTM.

$$\begin{aligned} [1, 2, 3, 4, 5] &\Rightarrow [6] \\ [2, 3, 4, 5, 6] &\Rightarrow [7] \\ [3, 4, 5, 6, 7] &\Rightarrow [8] \end{aligned}$$

Eg: Time series data = [1,2,3,4,5,6,7] and window size = 5. Five records from the data become a record of input data to be passed and 6th record becomes the output of the model. The last record, 8, wasn't present in the dataset. Likewise, trained LSTM models can predict next data points using historical readings. The dataset is then reshaped into a 3D matrix of shape (inputs, time-steps, features) as shown below.

$$[[[1], [2], [3], [4], [5]]]$$

C. Data Normalization

Normalization is a technique used to scale up/down data to the range of [0,1]. Normalization brings all features on a comparable scale and makes it easier for models to train on the data and generalize better.

$$X_{norm} = \frac{X - X_{min}}{X_{max} - X_{min}}$$

D. Splitting of the Dataset

The windowed and normalized data was divided into three disjoint sets - 80%, 10%, 10%, sequentially - Training set: used to train the model, Validation set: used to analyze the model's performance on unseen data while training, Testing set: used to evaluate the model's performance. The model is fine-tuned by the optimizer - Adam in our case, at every iteration, such that the validation error is minimized.

E. Hyperparameter Tuning and Model Evaluation

The following hyperparameters were tweaked and the models were evaluated on the testing set using the MSE metric.

- 1) No. of LSTM units (using a single LSTM layer).

Units	20	30	40	50	60	70	80	84
MSE	7.72	3.43	3.21	2.91	2.06	1.91	1.99	1.92

- 2) Dropout: percentage of random connections to be dropped in each layer (to avoid overfitting).

Dropout	0.1	0.2	0.3	0.4
MSE	1.91	4.19	3.43	4.33

- 3) Batch size: No. of data points after which the gradients are backpropagated.

Batch Size	16	32	48	60
MSE	1.81	1.861	2.15	1.97

- 4) Window size: The size of the rolling window.

- 5) Layers: No. of hidden layers in the network.

Window Size	24	48	60	84
MSE	1.81	2.48	1.63	2.63

Layers	1	2	3
MSE	1.63	2.09	2.21

TABLE I
FINALIZING THE BEST PERFORMING HYPERPARAMETERS

Parameter	Units	Dropout	Batch Size	Window Size	Layers
Best Value	70	0.1	16	60	1

On selecting the best value for each of the mentioned hyperparameters, the above table was obtained. After fitting 1000 epochs of a model with these parameters on the training dataset, the MSE (Mean Squared Error) obtained on the testing dataset is 0.0053.

$$\text{Mean Squared Error} = \frac{\sum_i (y_i - \hat{y}_i)^2}{n}$$

- n: Number of data records
- y_i : Actual value of the record i
- \hat{y}_i : Predicted value of the record i

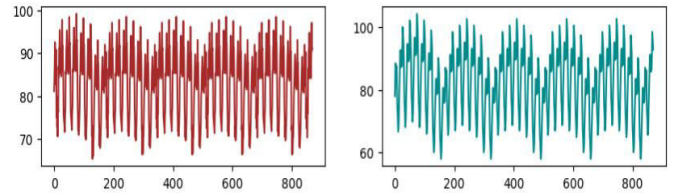

Fig. 1. Predicted (Left) and Actual (Right) Load Demand in GW vs Time

III. LOAD DEMAND FORECASTING

A. Data Acquisition

The finalized hyperparameters were further used to fit an LSTM model to the data gathered from an actual fan load of 12V and maximum current rating of 1A, with a simulated behavior of changing speeds, controlled by a PWM (Pulse Width Modulation) speed regulator. The voltage dropped across the fan's ends and the line current was measured using sensors, at regular intervals, to obtain a total of 1475 readings.

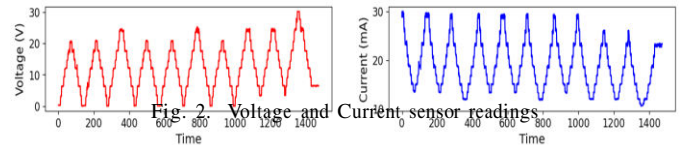

Fig. 2. Voltage and Current sensor readings
The sensor readings were calibrated to accurately represent the true voltage and current values. The voltage and current

values were then substituted in the below formula to obtain the load (power) demand readings.

$$\text{Power (W)} = \text{Voltage (V)} * \text{Current (mA)} * 0.001$$

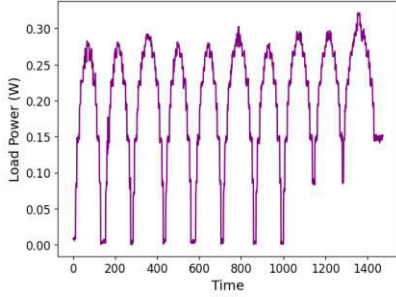

Fig. 3. Load Demand readings

B. Data Preprocessing

The load power readings were flattened into a 1-D series and a rolling window of size 60 was applied on to the data to transform it into a supervised learning matrix of sequences, using the approach discussed earlier. Further, the dataset was split into 80%, 10%, 10%, as the training, validation and testing sets followed by normalization.

C. Model Fitting and Evaluation

The best-performing hyperparameters listed in Table I were used to fit an LSTM model to the dataset, using a learning rate of 0.0001. The MSE of the trained model on the testing data was 0.0013. Hence, the model was successful in providing reliable estimates for the load demand pattern.

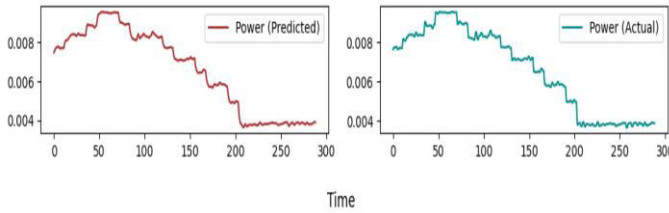

Fig. 4. Load Power (Predicted vs Actual) (W)

IV. ANALYSIS OF SOLAR DATA

A. Data Acquisition

The modeling of load behavior was followed by the analysis of solar power generation data. A 12V, 10W solar panel was connected to a dummy motor load (12 V, 1.5A maximum current rating). The voltage generated across the ends of the panel, the line current in the circuit, illumination, temperature, and humidity at the site were measured using sensors, at regular intervals. A total of 3892 readings were collected. The aim of the data collection was to use current (which depends on the load) as the target feature, which can be predicted

using the remaining features. Hence, given the - panel voltage, illumination, temperature, humidity - at any instant of the day,

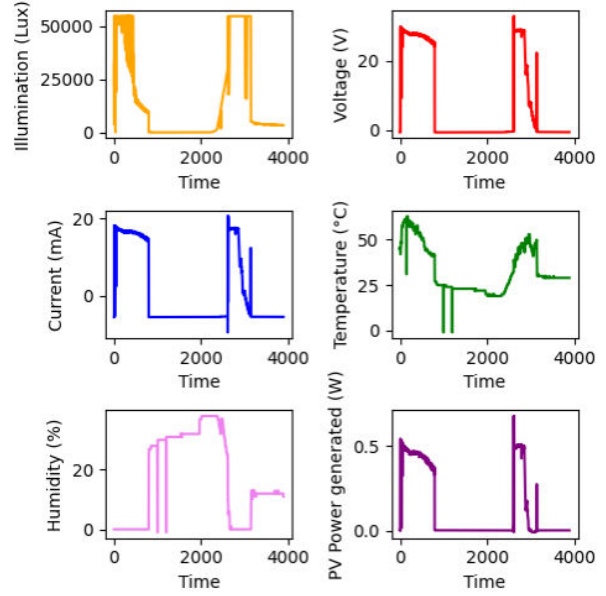

Fig. 5. Solar Power Generation readings

the line current can be predicted (even when no load is connected to the panel) and multiplied with the voltage to obtain the estimated solar power generation.

B. Data Preprocessing

The dataset was cleaned and split into 80%, 10%, and 10%, as the training, validation, and testing sets and normalized.

C. Model Training and Evaluation

A 2-layered MLP (Multi-Layer Perceptron) was trained on the dataset with the line current as the target feature. The layers contained 10 dense units each and ReLU (Rectified Linear Unit) activation function was applied at each layer. A learning rate of 0.0001 and the Adam optimizer were used to fit 100 epochs on the dataset.

$$\text{ReLU}(z) = \max(0,z)$$

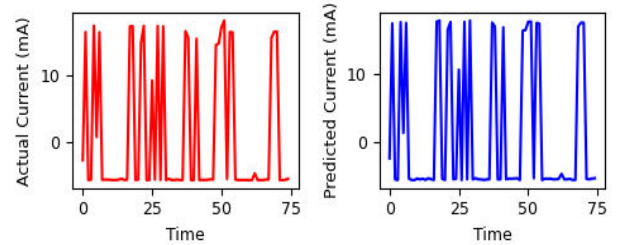

Fig. 6. Solar Line Current prediction

The trained model had an MSE of 0.31 on the testing set.

V. ENERGY MANAGEMENT SYSTEM

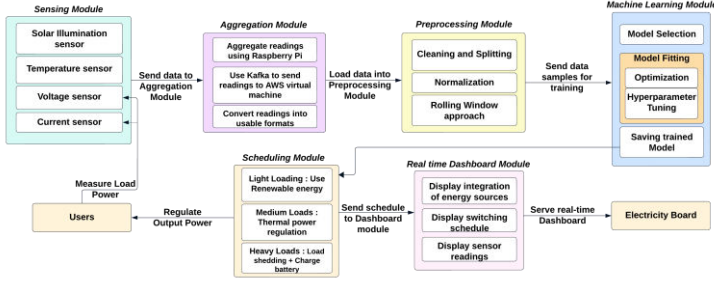

Fig. 7. System Architecture

Algorithm 1: Naive Power Scheduling Algorithm**Input:** Sensors, Window size=60, Burst time=30 minutes**Output:** None

```

(1) while True do
(2)   Illumination, Voltage, Temperature, Humidity ← Get
      readings(Sensors);
(3)   Current ← Solar model.predict();
(4)   Estimated solar power ← Voltage * Current (mA) * 0.001;
(5)   Size ← length(Historical Load readings);
(6)   Windowed readings ← Historical Load readings[Size - window
      size : Size];
(7)   Estimated demand ← Load model.predict(Windowed readings);
(8)   Battery power ← Sense battery charging();
(9)   Conventional power ← Estimated demand - Estimated solar
      power - Battery power;
(10)  User List ← Get all users in the grid();
(11)  Demand List ← Sense demand when switching on(User List);
(12)  Sort(Demand List, Arrival time, Power demand);
(13)  foreach demand in Demand List do
(14)    if demand.max ≤ Solar power then
(15)      Solar power -= demand.max;
(16)      demand.assign(Solar line);
(17)    end
(18)    else if demand.max ≤ Conventional power then
(19)      Conventional power -= demand.max;
(20)      demand.assign(Conventional line);
(21)    end
(22)    else if demand.max ≤ Battery power then
(23)      Battery power -= demand.max;
(24)      demand.assign(Battery line);
(25)    end
(26)    else
(27)      pass;
      // Implement Load shedding OR Connect
      to battery backup line
(28)    end
(29)  end
(30)  Clear demand list();
(31)  Turn off assigned demands after(burst time);
(32)  Actual demand ← Sense line current() * Sense voltage drop();
(33)  View Actual vs Predicted Load on Dashboard();
(34) end

```

A. System Overview

The proposed system (Fig. 7) can be deployed in Hybrid power plants, to automate the power generation in real-time, as per the estimated load demand.

1) **Sensing Module:**

- An illumination sensor: for sunlight readings.

- A temperature and humidity sensor: weather data.
- A combination of voltage and current sensors, to obtain load demand readings.

- Aggregation Module:** Aggregation of sensor readings using a Raspberry Pi, sending them to a virtual machine running on the AWS Cloud using Apache Kafka.
- Preprocessing Module:** Cleaning and normalization of the aggregated data; applying a rolling window.
- Machine Learning Module:** Fitting an LSTM model to the dataset, tuning its hyperparameters, validating its accuracy using the MSE metric, saving the model.
- Power Scheduling Module:** Switches the power sources' line connections at the users' end so each user gets connected to either the solar or conventional source.
- Dashboard Module:** Displays the actual power generation and load demand versus the estimates provided.

B. Power Scheduling Algorithm

Power scheduling is performed by regulating the switches on the user line (busbar) as discussed in Algorithm 1. Each user is assigned to one of the power sources - solar, battery backup, or conventional power source, depending on the power available with each source. The following are three operating cases, considered in the scheduling algorithm.

- When Demand < Renewable Generation:** The system allots renewable power to all users and extra power is used for charging backups.
- Renewable Generation < Power Demand < Power Plant Capacity:** Conventional Power = Estimated demand - Renewable Generation (output is controlled as per the load demand estimates). Uncertain loads can be handled using power backups/batteries.
- Power Plant Capacity < Power Demand:** Load shedding is carried out in the intended user's power line.

VI. RESULTS

The LSTM model trained on load demand data from the Dataset-of-HRP-38-test-system by Zhenyu Zhou [4] had a mean squared error of 0.0053 on the testing set, which comprised 10% of the readings from the entire dataset. The hyperparameters finalized from this training were used to train another model on data collected from a simulated fan load. The trained model resulted in an MSE of 0.0013 on the testing set.

VII. CONCLUSION

Hence, the domain of energy demand forecasting was explored, and an LSTM model was trained on the collected load demand dataset to estimate the power demand of the users in the future. Another neural network was trained to estimate the solar power generated at any time instant using data collected from an actual solar panel. A prototype for a Hybrid DC Microgrid was implemented, and power scheduling was done using a naive approach that makes use of the estimated load demand and solar power to regulate the conventional power. The users are allotted power from either of the sources, solar / conventional, depending on the power availability of each.

REFERENCES

- [1] C.-H. Liu, J.-C. Gu, and M.-T. Yang, "A Simplified LSTM Neural Networks for One Day-Ahead Solar Power Forecasting," *IEEE Access*, vol. 9, pp. 18967-18975, Jan. 22, 2021. DOI: 10.1109/AC-CESS.2021.3053638.
- [2] M. M. Shibl, L. S. Ismail, and A. M. Massoud, "An Intelligent Two-Stage Energy Dispatch Management System for Hybrid Power Plants: Impact of Machine Learning Deployment," *IEEE Access*, vol. 11, pp. 11212-11223, Feb. 6, 2023. DOI: 10.1109/ACCESS.2023.3243097.
- [3] "Power Sector in India," India Brand Equity Foundation, Dec. 2023. Available online: <https://www.ibef.org/industry/power-sector-india>
- [4] Zhenyu Zhuo, "DATASET-OF-HRP-38-TEST-SYSTEM," *IEEE Data-Port*, DOI: 10.21227/ggy4-7497, May 17, 2022.
- [5] B. Mohandes, M. Wahbah, M. S. El Moursi, and T. H. M. El-Fouly, "Renewable Energy Management System: Optimum Design and Hourly Dispatch," *IEEE Transactions on Sustainable Energy*, vol. 12, no. 3, pp. 1615, July 2021.
- [6] H. Karami, M. J. Sanjari, S. H. Hosseinian, and G. B. Gharehpetian, "An Optimal Dispatch Algorithm for Managing Residential Distributed Energy Resources," *IEEE Transactions on Smart Grid*, vol. 5, no. 5, pp. 2360, September 2014.
- [7] M. Tan, S. Yuan, S. Li, Y. Su, H. Li, and F. He, "Ultra-Short-Term Industrial Power Demand Forecasting Using LSTM Based Hybrid Ensemble Learning," *IEEE Transactions on Power Systems*, vol. 35, no. 4, pp. 2937, July 2020.
- [8] J.-B. Fiot and F. Dinuzzo, "Electricity Demand Forecasting by Multi-Task Learning," *IEEE Transactions on Smart Grid*, vol. 9, no. 2, pp. 544, March 2018.
- [9] S. S. Arnob, A. I. M. S. Arefin, A. Y. Saber, and K. A. Mamun, "Energy Demand Forecasting and Optimizing Electric Systems for Developing Countries," *IEEE Access*, vol. 11, pp. 11212-11223, Feb. 27, 2023. DOI: 10.1109/ACCESS.2023.3250110.
- [10] L. Hernandez, C. Baladron, J. M. Aguiar, B. Carro, A. J. Sanchez-Esguevillas, J. Lloret, and J. Massana, "A Survey on Electric Power Demand Forecasting: Future Trends in Smart Grids, Microgrids and Smart Buildings," *IEEE Communications Surveys & Tutorials*, vol. 16, no. 3, pp. 1460-1489, Third Quarter 2014.
- [11] D. H. Vu, K. M. Muttaqi, A. P. Agalgaonkar, A. Zahedmanesh, and A. Bouzerdoum, "Recurring Multi-layer Moving Window Approach to Forecast Day-ahead and Week-ahead Load Demand Considering Weather Conditions," *Journal of Modern Power Systems and Clean Energy*, vol. 10, no. 6, November 2022.
- [12] N. Uremovic, M. Bizjak, P. Sukic, G. Stumberger, B. Zalik, and N. Lukac, "A New Framework for Multivariate Time Series Forecasting in Energy Management System," *IEEE Transactions on Smart Grid*, vol. 14, no. 4, July 2023.
- [13] X. Wen and W. Li, "Time Series Prediction Based on LSTM-Attention-LSTM Model," *IEEE Access*, vol. 9, pp. 15-23, May 2023. DOI: 10.1109/ACCESS.2023.3276628.
- [14] M. Tan, S. Yuan, S. Li, Y. Su, H. Li, and F. He, "Ultra-Short-Term Industrial Power Demand Forecasting Using LSTM Based Hybrid Ensemble Learning," *IEEE Transactions on Power Systems*, vol. 35, no. 4, pp. 2937, July 2020.
- [15] J. Mubiru, "Predicting total solar irradiation values using artificial neural networks," *Renew. Energy*, vol. 33, no. 10, pp. 2329-2332, Oct. 2008.

Revolutionizing Healthcare: Early Detection of Skin Cancer through Innovative Imaging Technology

RohanDash,SakshiChavan,ShrutiGolesar,BalasahebTarle

Department of Computer Engineering

MVPS'S KBT College of Engineering

Nashik-422013, India

ddash098@gmail.com,chavansakshi236@gmail.com,shr

uti.d.golesar@gmail.com,tarle.balasaheb@kbtcoe.org

Abstract—A major global health concern, skin cancer highlights the significance of early detection for successful treatment and positive patient outcomes. The paper, "Revolutionizing Healthcare: Early Detection of Skin Cancer through Innovative Imaging Technology," is creating a sophisticated system for the early identification of potential skin cancer lesions by utilizing computer vision and machine learning techniques. The paper incorporates a preprocessed and feature-extracted dataset of images of skin lesions that has been carefully selected. A machine learning model, based on Convolutional Neural Networks, accurately classifies skin lesions as benign or potentially malignant. Its user-friendly web interface allows for easy uploading of images and retrieval of diagnostic results, making it accessible to medical professionals and individuals concerned about skin health. Privacy and ethical considerations are prioritized for patient data protection.

Index Terms—Skin Cancer Detection, Machine Learning, Computer Vision, Early Diagnosis

I. INTRODUCTION

"Revolutionizing Healthcare: Early Detection of Skin Cancer through Innovative Imaging Technology" is a groundbreaking approach to skin cancer, a major worldwide health concern. This paper highlights the importance of early detection, as skin cancer can have serious implications. Our program intends to automate the skin cancer diagnostic process by leveraging machine learning and computer vision capabilities, with an emphasis on accessibility, accuracy, and ethical concerns. Skin cancer comes in several forms, sun exposure and changed lifestyles have both contributed to an increase in the incidence rate. Early identification is critical for enhancing treatment outcomes and potentially saving lives. To meet this critical demand, our study employs powerful machine learning models, notably Convolutional Neural Networks (CNNs), which are well-known for their performance in image classification tasks. These models are extensively trained on a wide range of skin lesion images, allowing them to detect minor patterns associated with various forms of skin cancer. Our paper prioritizes ethical considerations in its AI-powered approach to early skin cancer detection. We emphasize fairness, transparency, and robust data privacy. Continuous evaluation identifies and addresses biases in the system, ensuring equitable results for all users regardless of background or skin

type. Stringent security measures safeguard patient data and guarantee compliance with data protection regulations. The system's scalability ensures smooth operation for a growing user base and increasing image uploads. Educational resources raise awareness about skin cancer and promote prevention. Additionally, users can report urgent cases, facilitating timely medical intervention for critical situations. This initiative transcends a technological solution. It's a public health effort that prioritizes responsible development, user empowerment, and improved healthcare outcomes. In essence, "Revolutionizing Healthcare: Early Detection of Skin Cancer through Innovative Imaging Technology" is more than a technological advancement; it is a public health initiative that combines accessibility, accuracy, privacy, ethics, and education to empower individuals to take control of their skin health and contribute to improved healthcare outcomes.

II. LITERATURE SURVEY

K. Mridha et al. [1] propose an interpretable skin cancer classification using an optimized Convolutional Neural Network (CNN) for a smart healthcare system. The authors emphasize the importance of accurate diagnosis in skin cancer detection, addressing challenges such as long waiting times and subjective interpretations. Their deep learning model aims to improve the speed and accuracy of diagnosis, leading to earlier detection and treatment, while also reducing the workload for healthcare professionals.

Lubina Riaz et al. [2] present a comprehensive joint learning system for detecting skin cancer. Their work focuses on developing a non-invasive method for in-vivo diagnosis and early detection of biological abnormalities using microwave reflectometry. The authors highlight the need for objective, quick, and non-invasive methods for diagnosing skin conditions, especially given the increasing incidence rates of skin cancer globally.

R. Schiavoni et al. [3] introduce a low-cost microwave reflectometry system for early skin cancer detection, emphasizing IT's crucial role in healthcare and its potential for accurate diagnostics.

III. TRAINING

In our system, we've utilized the HAM10000 dataset. It is an open source collection of over 10,000 close-up skin images used by doctors to diagnose skin cancer. Researchers use datasets like this one to develop computer programs that can also identify skin cancer from pictures. Our goal is to create a system that analyzes a picture of your skin and early determines whether the skin lesion is cancerous or not.

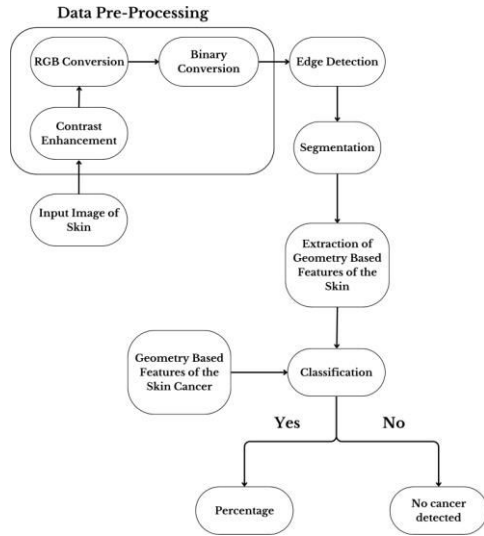

Fig. 1. System Architecture

A. Image Preprocessing

According to Figure 1, preprocessing tasks are divided into three subtasks, which are as follows:

- 1) Contrast Enhancement: Techniques like histogram equalization can be implemented using libraries like OpenCV or scikit-image (focusing on computer vision tasks) to improve the visibility of features within the skin images from the HAM10000 dataset.
- 2) RGB Conversion: We might utilize libraries like OpenCV or Pillow (PIL Fork) to convert the RGB images from the dataset to a different color space, such as grayscale. This can be beneficial for certain deep learning models that work better with single-channel inputs.
- 3) Binary Conversion: For specific analyses, converting the preprocessed images to binary (black and white) might be necessary. Libraries like OpenCV or scikit-image provide functionalities for thresholding and binarization.

B. Train Test Split

The train-test split prepares the dataset for training and testing a deep learning model for skin cancer classification. To overcome the data's inherent class imbalance, which could bias the model toward the dominant class, we used cost-sensitive learning. This technique assigns weights to various

classes based on their representation in the dataset. Smaller classes have larger weights, which counteracts the bias and improves the model's ability to recognize them. The formula for determining these weights is shown in the equation.

$$\text{class_weight}_i = \frac{\sum_{j=1}^n N_j}{N_i} \quad (1)$$

where N_i is the number of samples in class i .

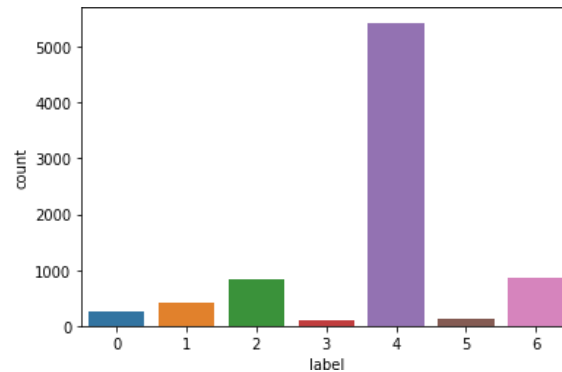

Fig. 2. Visualisation of imbalanced classes

Fig. 2 shows that there is a class imbalance for class 4 comprising more than 65% of the overall data, this will have an impact later during the classification. So in order to mitigate this problem we will be using oversampling technique.

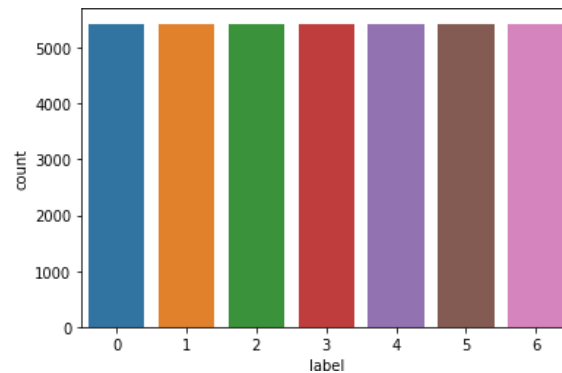

Fig. 3. Visualisation after using oversampling on imbalanced classes

Fig. 3 is now balanced and will not create any discrepancies during the classification process.

C. Image Reshaping

The image reshaping utilizes `matplotlib.pyplot (plt)` and `random` libraries to display three random images from the training dataset (`x_train`). It selects a random integer as an index, reshapes the image data into a `28x28x3` format for grayscale images, and displays them using `plt.imshow` with corresponding titles.

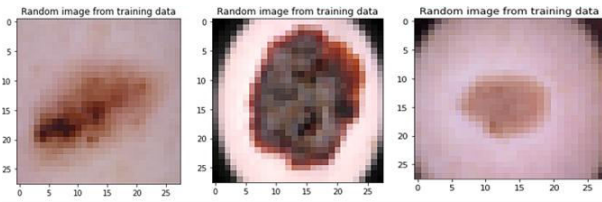

Fig.4.Reshapingofinputimage[1]

IV. MODEL BUILDING

The core of this early skin cancer detection system is the Convolutional Neural Network (CNN). This type of deep learning model excels at analyzing grid-like data, perfectly suited for processing images. The specific CNN architecture in this system is designed to extract informative features from skin lesion images in a hierarchical manner. By progressively extracting higher-level features, the model aims to achieve accurate classification and helps in generating likelihood percentage of skin cancer.

A. Steps for Convolutional Neural Network (CNN) algorithm

- 1) **Sequential Model:** To add layers sequentially, the sequential model from the keras library is utilized.

```
model=Sequential()
```

- 2) **Convolutional Layers:** The model utilizes several convolutional layers (Conv2D). These layers are the core of CNNs and perform feature extraction from the input images.

$$\text{Output size} = \frac{\text{Input size} - \text{Kernel size} + 2 \times \text{Padding}}{\text{Stride}} + 1 \quad (2)$$

a) First Convolutional Layer: This layer employs 16 filters with a 3x3 kernel size, sliding across the image to extract features like edges and textures. Input shape indicates 28x28 pixel images with 3 channels (likely RGB). Using the relu activation function introduces non-linearity for learning complex relationships. Padding='same' maintains spatial dimensions in the output feature map for consistent processing.

```
model.add(Conv2D(16, kernel_size=(3,3), input_shape=(28, 28, 3), activation='relu', padding='same'))
```

b) Subsequent Convolutional Layers: The model stacks additional convolutional layers with increasing numbers of filters (32, 64, 128, and 256). This allows the network to extract progressively higher-level features from the data. Each layer uses a kernel size of (3x3) and the relu activation function for non-linearity.

- 3) **Pooling Layers:** The model incorporates MaxPool2D layers after some convolutional layers. These layers perform downsampling, reducing the dimensionality of the data while retaining the most important features. The pool size of (2x2) means the filter takes strides

of 2 pixels in both width and height, resulting in a 4x reduction in feature map size.

```
model.add(MaxPool2D(pool_size=(2,2)))
```

$$\text{Output size} = \frac{\text{Input size} - \text{Pool size}}{\text{Stride}} + 1 \quad (3)$$

- 4) **Batch Normalization:** The model incorporates Batch Normalization layers after some convolutional layers. This technique helps improve training stability and speed by normalizing the activations of neurons within a layer.

```
model.add(tf.keras.layers.BatchNormalization())
```

- 5) **Flattening:** After the convolutional layers, the model utilizes a Flatten layer. This layer transforms the multi-dimensional feature maps from the convolutional layers into a single one-dimensional vector suitable for feeding into fully connected layers.

```
model.add(Flatten())
```

- 6) **Dropout Layers:** The model includes Dropout layers with a rate of 0.2 after the flattening layer and some fully connected layers. Dropout randomly drops a certain percentage of neurons during training, preventing overfitting and encouraging the network to learn more robust features.

```
model.add(tf.keras.layers.Dropout(0.2))
```

- 7) **Fully Connected Layers:** After the flattening layer, several fully connected layers (Dense) are added for classification, learning relationships between extracted features and skin cancer types. Each layer has neurons (256, 128, 64, 32) for learning complex feature combinations. Relu activation maintains non-linearity. Batch normalization enhances training stability after some fully connected layers.

```
model.add(Dense(256, activation='relu'))
```

- 8) **Output Layer:** The final layer is another fully connected layer with 7 neurons and a softmax activation function. 7 neurons represent the 7 possible classes for skin cancer types (or potentially including a background class). The softmax activation ensures the output layer's values sum to 1, representing probabilities for each class. This allows the model to predict the most likely class for a given image.

```
model.add(Dense(7, activation='softmax'))
```

- 9) **Model Summary:** Finally, the system uses model.summary() to print a summary of the model architecture, including the number of layers, parameters, and output shape. This provides a high-level overview of the network's complexity.

```
model.summary()
```

This CNN design uses convolutional layers for feature extraction, pooling layers for downsampling, and fully connected layers for classification. Dropout and Batch Normalization approaches are used to increase training performance while avoiding overfitting. By training this

model on a labeled skin cancer dataset, it is beable to early detect the skin cancer based on the image uploaded.

These graphs provide a clear visualization of the model’s learning progress and its ability to generalize across different data subsets.

B. Activation Functions

- 1) **ReLU Function:** ReLU is a widely used activation function that introduces non-linearity by outputting the input directly if it is positive; otherwise, it outputs zero. It helps in overcoming the vanishing gradient problem and speeds up training.

$$\text{ReLU}: f(x) = \max(0, x)$$

- 2) **Softmax Function:** Softmax is often used in the output layer for multi-class classification tasks. It converts raw scores (logits) into probabilities, where each class probability is between 0 and 1, and the sum of all probabilities is equal to 1.

$$\text{Softmax}: P(y=j|z) = \frac{e^{z_j}}{\sum_{k=1}^K e^{z_k}}$$

C. Optimizer

Our early skin cancer detection system uses the Adam optimizer to train the model, like a coach adjusting its weights based on errors. We set a learning rate of 0.001 for these adjustments. The model also tracks its ‘accuracy’ to measure how well it classifies skin conditions.

$$\text{Adam optimizer: } \hat{\theta}_{t+1} = \hat{\theta}_t - \sqrt{\frac{\hat{m}_t}{\hat{v}_t + \epsilon}}$$

V. MODEL EVALUATION

Model evaluation assesses the CNN’s generalization to new skin images, comparing predictions (skin cancer presence and stage) to actual diagnoses in a separate dataset. This determines real-world accuracy and identifies areas needing further training or adjustments for system improvement.

A. K-fold cross-validation

It boosts skin cancer detection by training and validating a CNN on diverse image subsets. It divides data into k folds, improving model reliability and generalization across subsets. This process enhances the system’s effectiveness in detecting skin cancer. Additionally, the table I below provides a summary of the training and validation metrics obtained from the k-fold cross-validation process for our skin cancer detection system:

TABLE I
SUMMARY OF TRAINING AND VALIDATION METRICS FOR 5 FOLDS

Fold	Training Loss	Training Accuracy	Validation Loss	Validation Accuracy
1	0.0528	0.9816	0.2893	0.9191
2	0.0113	0.9966	0.7344	0.8303
3	0.0061	0.9984	0.0967	0.9734
4	0.0511	0.9825	1.0220	0.7795
5	0.0131	0.9962	0.1279	0.9569

Furthermore, the graphs corresponding to each fold (Fig. 5, Fig. 6, Fig. 7, Fig. 8, Fig. 9) visually represent the training and validation performance of four CNN models on these folds.

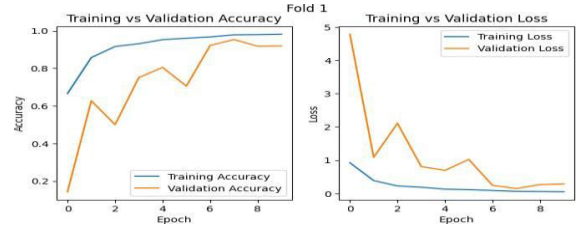

Fig.5.K-Fold1

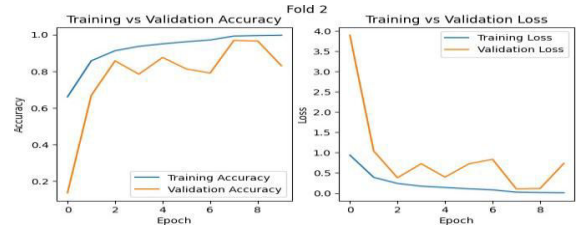

Fig.6.K-Fold2

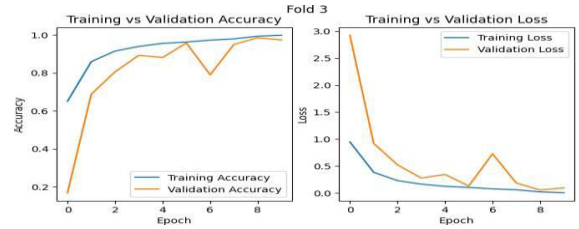

Fig.7.K-Fold3

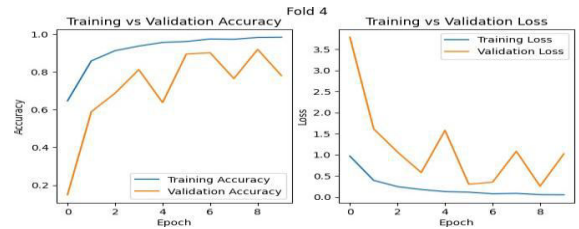

Fig.8.K-Fold4

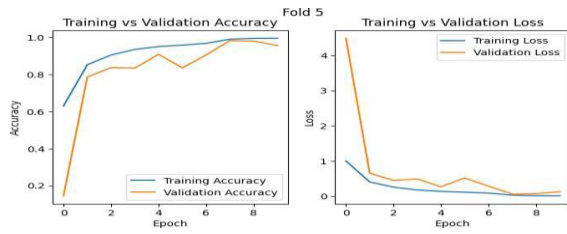

Fig.9.K-Fold5

VI. RESULT

Following image analysis, an automated report will be issued for each user. This report will include user information as well as a pie chart presentation. By referring Table II which will divide the possibility of the image carrying a skin lesion into two percentages: the presence or absence of skin cancer. The larger portion will be considered as the most likely result. The likelihood of having skin cancer can be expressed as a conditional statement:

$$\text{Likelihood of having skin cancer} = \begin{cases} \text{Higher, if } P \geq T \\ \text{Lower, if } P < T \end{cases}$$

where P is the percentage value and T is the threshold value.

TABLE II
CATEGORIZATION OF SKIN CONDITIONS

Serial	Class	ClassName	Category
1	0	Actinikeratoses and intraepithelial carcinomae	Cancerous
2	1	Basal cell carcinoma	Cancerous
3	2	Benign keratosis-like lesions	Non-Cancerous
4	3	Dermatofibroma	Non-Cancerous
5	4	Melanocytic nevi	Non-Cancerous
6	5	Pyogenic granulomas and hemorrhage	Can lead to cancer
7	6	Melanoma	Cancerous

VII. LIMITATIONS

Medical diagnosis is a complex process, with diseases evolving alongside the advancement of computer technology. It is critical to understand our system's strengths and limits. While our system is an excellent tool for early diagnosis of probable skin cancer, it is important to note that its current focus is solely on early skin cancer detection. Cancer is of many forms, and our technique may not be effective for diagnosing other types of tumors. To function properly, our skin cancer detection technology, which is web-based, requires a consistent internet connection. This reliance on internet connectivity can cause issues for customers in areas with low internet access or who prefer offline solutions.

CONCLUSION

"Revolutionizing Healthcare: Early Detection of Skin Cancer through Innovative Imaging Technology" addresses the crucial issue of diagnosing skin cancer at an early stage. This user-friendly system utilizes advanced artificial intelligence to empower individuals in monitoring their skin health proactively. The paper emphasizes accessibility, making the system easily accessible, while also focusing on educating users to raise awareness about skin cancer and preventive measures. The development process revolves around creating highly precise machine learning models for dependable detection. However, the paper goes beyond this by incorporating ethical considerations and robust privacy measures to ensure fairness, transparency, and top-notch data protection. Ultimately, "Revolutionizing Healthcare: Early Detection of Skin Cancer through Innovative Imaging Technology" aims to be more than just a technological advancement; it's a public health initiative that empowers individuals, encourages early intervention, and aims to enhance patient outcomes, contributing to a healthier society.

REFERENCES

- [1] K. Mridha, M. M. Uddin, J. Shin, S. Khadka and M. F. Mridha, "An Interpretable Skin Cancer Classification Using Optimized Convolutional Neural Network for a Smart Healthcare System," in IEEE Access, vol. 11, pp. 41003-41018, 2023.
- [2] Lubina Riaz, Hafiz Muhammad Qadir, Ghulam Ali, Mubashir Ali, Muhammad Ahsan Raza, Anca Jurcat, and Jehad Ali "A Comprehensive Joint Learning System to Detect Skin Cancer", IEEE Journals & Magazine, Volume 11, Pages 79434-79444.
- [3] R. Schiavoni, G. Maietta, E. Filieri, A. Masciullo and A. Cataldo, "Microwave Reflectometry Sensing System for Low-Cost in-vivo Skin Cancer Diagnostics," in IEEE Access, vol. 11, pp. 13918-13928, 2023.
- [4] S.A. AlSalman, T.M. Alkaff, T. Alzaid and Y. Binamer, "Non-melanoma skin cancer in Saudi Arabia: Single center experience", Ann. Saudi Med., vol. 38, no. 1, pp. 42-45, Jan. 2018.
- [5] M. A. Albahar, "Skin lesion classification using convolutional neural network with novel regularizer", IEEE Access, vol. 7, pp. 38306-38313, 2019.
- [6] M. R. Hasan, M. I. Fatemi, M. M. Khan, M. Kaur and A. Zaguia, "Comparative analysis of skin cancer (benign vs. malignant) detection using convolutional neural networks", J. Healthc Eng., vol. 2021, Dec. 2021.
- [7] G. Swann, "The skin is the body's largest organ", J. Vis. Commun. Med., vol. 33, no. 4, pp. 148-149, 2010.
- [8] M. A. Albahar, "Skin lesion classification using convolutional neural network with novel regularizer", IEEE Access, vol. 7, pp. 38306-38313, 2019.
- [9] M. R. Hasan, M. I. Fatemi, M. M. Khan, M. Kaur and A. Zaguia, "Comparative analysis of skin cancer (benign vs. malignant) detection using convolutional neural networks", J. Healthc Eng., vol. 2021, Dec. 2021.
- [10] Y. Li and L. Shen, "Skin lesion analysis towards melanoma detection using deep learning network", Sensors, vol. 18, no. 2, pp. 556, Feb. 2018.
- [11] D.S. Lakshmi, A. Divya, M. B. Sai, K. D. Rama, K. J. Rani and M. Vakkalagadda, "Skin Cancer Diagnosis Using Deep Convolutional Generative Adversarial Network for Image Classification," 2024 2nd International Conference on Intelligent Data Communication Technologies and Internet of Things (IDCIoT), Bengaluru, India, 2024, pp. 1219-1225.

AI Based Smart Comprehensive Support System for Senior Citizens

Chetana Patil¹, Ajinkya Kamble², Tejas Jadhav³, Dr. Sanjay Koli⁴

^{1,2,3}UG students and ⁴Professor at Electronics & Tele-communication Engineering Department,

Ajeenkya D Y Patil school of Engineering, Pune, Maharashtra, India

ABSTRACT: Elderly people living alone are facing different challenges and it is impacting their physical, mental, and emotional well-being. The proposed AI-based smart comprehensive support system for elderly individuals living alone addresses critical challenges faced by this demographic. By leveraging advanced technologies such as deep learning, image analysis, and real-time communication, the system aims to enhance the overall well-being and safety of elderly people. The system employs MediaPipe and OpenCV, deep face libraries for deep learning models on the front end to recognize hand gestures and human facial emotion in real-time. The system uses the HARRCASCAD-DataSet for ensuring a diverse and representative set of data to enhance the model's accuracy in emotion and gesture detection and detects four types of emotions such as happy, sad, angry, and neutral. Recognizing these emotions provides a nuanced understanding of the elderly person's mental state. When the system detects signs asking for help by the elderly people, it automatically sends SMS to emergency service providers, ensuring quick response and appropriate assistance. Additionally, the system also sends alerts to family members or caregivers, keeping them informed about the elderly person's well-being. By addressing both physical and emotional well-being, the proposed comprehensive support system contributes to the independence and safety of elderly individuals living alone.

Keywords: Face Recognition, Emotion Detection, OpenCV, deepface, Gesture Detection, mediapipe.

I. INTRODUCTION

Elderly individuals living alone encounter a myriad of challenges that profoundly impact their physical, mental, and emotional well-being. These demographic faces unique struggles stemming from isolation, health concerns, and the potential for emergencies that necessitate prompt intervention. These challenges are multifaceted, ranging from physical health concerns to the intricacies of emotional well-being. As society witnesses an increasing trend of aging populations living independently, the need to address these challenges becomes paramount. The repercussions of these issues not only affect the elderly individual themselves but also extend to their families and caregivers.

These challenges faced by elderly individuals living alone underscore the pressing need for innovative and comprehensive solutions that cater to their unique needs. The significance of addressing these challenges lies in the potential to significantly improve the quality of life for a demographic

that often grapples with isolation, health concerns, and emergencies. The proposed artificial intelligence (AI) based system not only addresses the challenges faced by the elderly but also shapes the future landscape of elderly care through technology-driven interventions.

An AI-based smart comprehensive support system designed to address the multifaceted challenges faced by elderly individuals living alone is presented in this paper. Leveraging advanced technologies like deep learning and real-time communication, the system is tailored to enhance the well-being of this demographic. A thorough literature review explores existing support systems and prior AI-based research in elderly care. The methodology section outlines the development process, emphasizing the deep learning model's architecture, mediapipe and real-time analysis with OpenCV, deepface. Results showcase the system's proficiency in emotion and gesture recognition. The discussion section interprets these findings, comparing the proposed system with existing solutions and addressing limitations. The conclusion summarizes key contributions and outlines future research possibilities.

II. LITERATURE SURVEY

Emotion / Facial Recognition is indeed a dynamic field with immense potential for various industries. The integration of multiple physiological signals is a promising approach for improving the accuracy of emotion recognition models. However, there are still challenges to overcome in terms of extracting and integrating these signals effectively. One of the key challenges in multi-physiological signal extraction is ensuring the compatibility and synchronization of different types of sensors [1]. Additionally, the interpretation of these signals can be complex, as emotions are influenced by a wide range of factors, both internal and external. Advancements in signal processing techniques, such as machine learning (ML) algorithms, can help address these challenges by enabling the development of more robust and adaptive emotion recognition models. By leveraging the complementary information provided by multiple physiological signals, researchers and developers can enhance the accuracy and reliability of these systems, unlocking new possibilities for emotion-aware technologies. In conclusion, while there are still hurdles to overcome, the ongoing research and development in the field of multi-physiological signal extraction and multimodal emotion recognition hold great promise for the future of emotion recognition technology.

Emotions can indeed serve as a valuable feedback system for businesses. The AI-based feedback systems using emotion recognition [2] sounds intriguing, particularly with the use of the Smart Iterative Calculator (SIC) to calculate emotions. However, the system failed to address potential issues such as

system faults or biases to ensure the accuracy and fairness of the feedback generated.

Facial Emotion Recognition (FER) is a technology that can be a key component to solve the problem of taking care of the elderly at home. The automatic detection of emotional expression in older adults is important in mental health assessment. A hybrid object detection model is proposed in [3], which is based on the faster R-CNN, SSD, and YOLOv5, for solving the emotion detection problems. This approach has increased the accuracy to 94.07%, to detect the FER of elderly people.

Understanding the emotions of elderly people is vital for knowing their psychological well-being. The authors in [4] has proposed a system based on ML and audio visualizer to understand the emotion of a patient. The system effectively detects emotions but still lacks in making the system real-time. Augmented reality (AR) and AI are the two most prominent technologies of the new era and used by [5] to design a system called Long Short-term Memory (LSTM) for detecting emotions with great accuracy.

A fusion algorithm using a camera and Frequency Modulated Continuous Wave (FMCW) Radar for emotion recognition was developed by Ming-A Chung [6]. Their experimental results indicate that the proposed method can stably recognize emotional states. The FMCW radar was used to detect the heart rate. The bottleneck of this system is that it is still inefficient in detecting the heart rate and gives many false alarms.

Detecting emotions through text presents a formidable challenge. For instance, in a study by [7], the proposed system tackles this challenge by leveraging a weighted pooling pre-trained RoBERTa model to discern emotions within textual content effectively. However, the system faces constraints in accurately detecting emotions when confronted with lengthy paragraphs as input. To augment its proficiency in handling long texts, future enhancements could entail the integration of BERT models, offering heightened efficiency in emotion detection from textual data.

Emotion detection plays a crucial role in enhancing performance and achieving better outcomes, as evidenced in [8]. The study employs an AI-based Convolutional Neural Network (CNN) to enhance student engagement during classroom sessions. By accurately detecting emotions, the system aims to create a more interactive and dynamic learning environment. However, it is important to acknowledge potential limitations inherent in the technology. For instance, the accuracy of emotion detection algorithms may vary, impacting the system's ability to effectively gauge students' emotional states. Additionally, constraints in eye movement analysis, which is often used as a proxy for emotional response, could pose challenges in accurately interpreting students' reactions. These limitations highlight the need to address technical challenges and optimize the effectiveness of systems like iSEEDS (Integrated Student Engagement and Emotion Detection System).

Thus, the literature survey shows a significant drawback of the existing techniques giving false alarms regarding various negative emotions. The proposed system, in this paper, addresses this limitation by incorporating two models such

as emotion detection and gesture detection. This approach effectively reduces false alarms and enhances the accuracy of detecting dangerous situations for elderly individuals.

III. METHODOLOGY

The proposed system utilizes the emotion and gesture database. The system employed a Haar classifier for emotion and gesture detection is done using OpenCv, deepface, and mediapipe. These Haar-like features can effectively capture changes in gray level of the images, making them suitable for explaining facial features due to their characteristic contrast changes. However, the computation of eigenvalues was extremely time-consuming. To improve calculation speed, the integral graph method was employed to compute the Haar-like values.



Figure 1. Face detection stages.

Figure 1 illustrates the Face detection stages. Face detection is a computer vision technology that locates human faces in images or video frames. It works by extracting features characteristic of faces, using algorithms like Haar cascade for classification. After classification, post-processing techniques refine results. Finally, the output typically includes bounding boxes around detected faces. Feature extraction in face detection involves identifying and capturing distinctive attributes of faces, such as patterns of intensity, texture, or edges. Common techniques include Haar cascade. The extracted features are represented as numerical vectors and used to distinguish faces from other objects or backgrounds. Face recognition is a technology that identifies individuals by analyzing unique features of their faces. It involves detecting faces, extracting features, comparing them with a database, and making a decision based on similarity scores.



Figure 2. Gesture detection stages.

Figure 2 illustrates the Gesture detection stages. Gesture detection interprets human movements captured by sensors like cameras or accelerometers. It extracts features from these movements, recognizes specific gestures using machine learning, maps them to commands, and provides feedback to users. It enables intuitive interaction with devices and applications. Gesture extraction involves capturing human movements using sensors, preprocessing the data to clean and enhance it, extracting meaningful features representing the gestures, optionally reducing the dimensionality of the features, recognizing specific gestures using machine learning, mapping them to commands, and providing feedback to users. Gesture recognition interprets human gestures, captured by sensors, to understand user commands. It involves extracting features, recognizing gestures using machine learning, mapping them to actions, and providing feedback.

The proposed system uses the flowchart as mentioned in Figure 3. The flowchart outlines the sequential steps involved in detecting emotion and gesture as

1. **Initial Stage:** The system initiates by capturing input from the webcam, encompassing gestures and facial expressions. This stage serves as the entry point for the analysis of human interaction cues.
2. **Face and Gesture Detection:** The system identifies and marks faces and gestures within the captured input. This process involves algorithms capable of recognizing facial landmarks and tracking hand movements, enabling precise localization and delineation of relevant features.
3. **Feature Extraction:** Subsequent to the identification and marking of faces and gestures, the system proceeds with feature extraction. This step involves isolating and extracting pertinent attributes from the marked regions, such as the spatial arrangement of facial landmarks and the trajectory of hand gestures.
4. **Emotion and Gesture Detection:** The extracted facial and hand features serve as input for the emotion detection and gesture recognition stages. Specialized algorithms analyze these features to discern patterns indicative of specific emotions and gestures. By leveraging machine learning models trained on diverse datasets, the system can accurately classify a wide range of emotional states and gestural expressions.
5. **Decision Making:** Upon completion of the emotion and gesture detection processes, the system engages in decision-making based on the obtained results. It compares the detected emotions and gestures with predefined criteria or thresholds established by the underlying algorithms. If the analysis indicates a "help needed" scenario, such as expressions of distress or specific distress signals, the system activates a response mechanism, routing to an emergency contact number for prompt intervention. Conversely, if no critical indicators are detected, the system continues monitoring for further cues, ensuring continuous vigilance and responsiveness to evolving interaction dynamics.

This comprehensive elaboration provides a deeper insight into each step of the flowchart, elucidating the intricacies of the process involved in detecting and responding to human emotions and gestures captured via webcam.

Algorithm for Analyzing Subjects, Converting to Grayscale, Cropping, and Taking Appropriate Action

Input:

- Frame containing subject(s)
- Haar cascade dataset for face detection
- Classification model for emotion recognition
- Mediapipe for gesture recognition

Output:

Processed frame with appropriate action taken

1. Initialization:

Initialize frame counter (counter) to 0.

2. Processing Loop:

Loop over each frame in the video stream:

a. Increment the frame counter.

b. Use the Haar cascade dataset to detect faces in the frame.

c. For each detected face:

i. Convert the face region to grayscale.

ii. Crop the grayscale face region to focus on facial features.

iii. Use OpenCV or deepface to recognize emotions in the cropped face region.

iv. Use Mediapipe to detect gestures made by the subject.

v. Action Determination:

- If the recognized emotion indicates distress or danger and a specific gesture is detected (e.g., raising hand), trigger an emergency alert.

- If the recognized emotion indicates sadness or anxiety, play a soothing message.

- If the recognized emotion indicates happiness or calmness, continue monitoring without taking any action.

vi. Display the processed frame with appropriate action taken.

d. End of Video Stream:

If the end of the video stream is reached, exit the loop.

3. End of Algorithm.

Various steps involved to perform emotion & gesture detection using OpenCV, deepface & mediapipe are as follow.

1. Upon the completion of software installation and integration of the Haar cascade dataset [9], our attention turns to scrutinizing groups of images meticulously. This pivotal stage is essential for ensuring the accuracy of our findings and securing an abundance of data for analysis. Employing diverse methodologies, we strive to amplify the depth and precision of the extracted information, thereby enhancing the overall quality of our results.

2. The dataset is then organized into two different directories containing all the images and information about the different types of emotions and gestures.

3. After running the sample images through the Python code, all the output images are sorted in the order of emotions, and the same for the gestures.

4. Different types of classes can be used in OpenCV, deepface for emotion recognition and mediapipe for gesture recognition.

5. OpenCV, deepface provides four predefined classifiers, so to detect as many as faces possible.

6. We used skeleton-based recognition with mediapipe to detect gestures, improving the accuracy by analyzing movements more precisely.

7. The dataset is divided into a Training set and a Classification set. The training set is used to teach the type of emotions and gestures by extracting information from several images and the classification set is used to estimate the classifier performance.

8. The subject on each frame is analyzed, converted to grayscale, cropped and system take appropriate action.

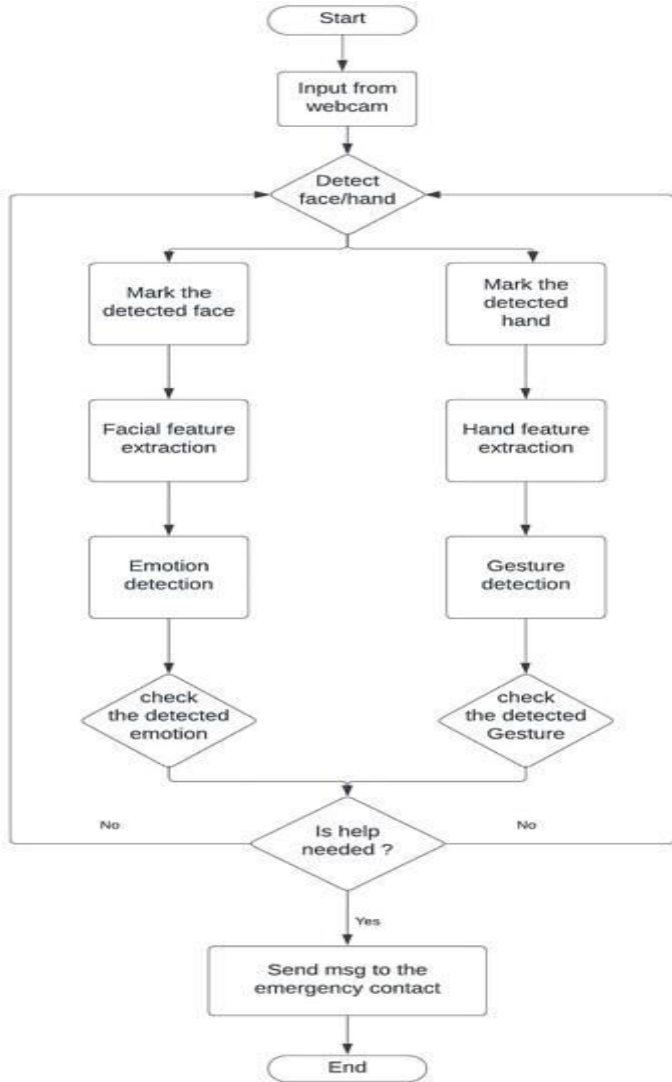

Figure3.FlowChart

IV RESULTS AND DISCUSSIONS

The emotional intensity is calculated using the proposed system for four emotions of human as shown in figure 4(a) through 4(d)

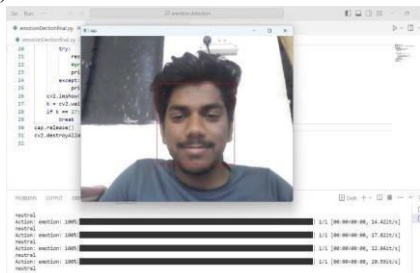

Figure4(a).EmotionRecognitionOutput:Neutral

Figure 4(a) shows a Neutral subject detected by using the haarcascadedatasetandFERbyusing68facelandmarks.The correctlandmarksweredetectedbythemethodandthesystem results in detecting Neutral emotion.

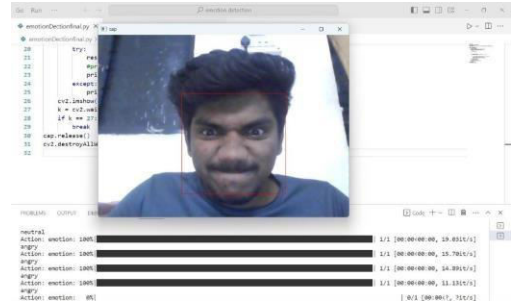

Figure4(b).EmotionRecognitionOutput:Angry

InFigure4(b)thesystemutilizestheHaarcascadedatasetand Facial Expression Recognition (FER), employing advanced facialfeatureanalysis techniques.Throughthisapproach,the system effectively identifies an angry expression in the subject. By accurately detecting essential facial cues, the method achieves successful recognition of the emotion of anger within the systems.

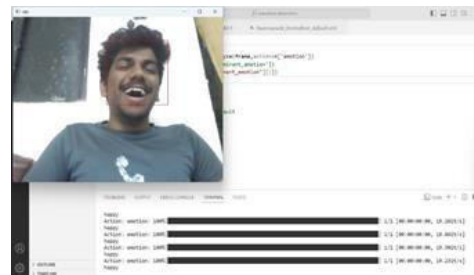

Figure4(c).EmotionRecognitionOutput:Happy

InFigure(c)oneiscalled"Haarcascade"forfindingfacesin images,andanotheriscalled"FER"whichlooksat68specific points on a face-asystem identifies a personsmiling.First,it found the face using the Haar cascade, then pinpointed the importantfacialfeatures using the FER dataset.By analyzing these features, like the corners of the mouth and eyes, the system determined the person was showing a happy expression. In simpler terms, it accurately detected and labeled the happy emotion on the person's face.

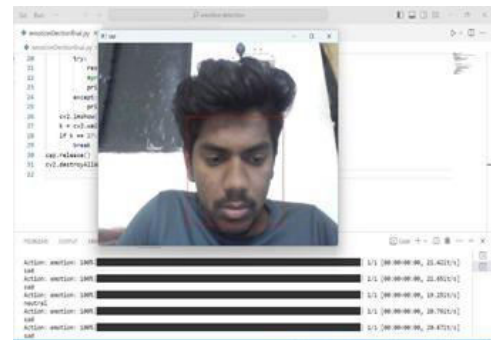

Figure4(d).EmotionRecognitionOutput:Sad

In Figure(d) The system used two tools: one to find faces in pictures(Haarcascade),andanother to pinpoint keypoints on those faces (FER dataset with 68 points). By putting these together, it could figure out if someone looked sad. It found the face first, then looked at where key points were, like the corners of the eyes and mouth. After checking these points, it was decided if the person looked sad. So, it basically figured out correctly labeled the sad expression on the person's face.

The gesture intensity is calculated successfully for two types of hand gesture of human such as need help and all ok as shown in figure 4 (e) and 4 (g).

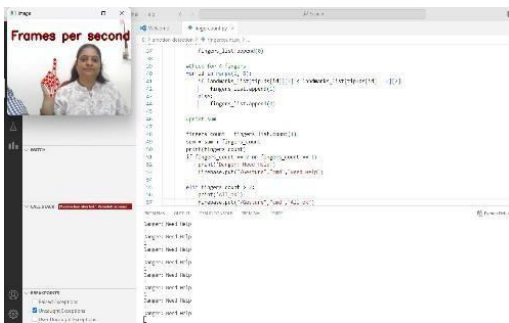

Figure 4(e). Hand Recognition Output: Need Help

Figure 4(e) depicts a subject with a hand gesture detected using skeleton-based Recognition and media pipe. The system accurately identifies one finger, indicating danger, and subsequently alerts with a "danger" message. This Proposed system generates a real-time SMS alert in case of emergencies and aims to enhance safety and responsiveness in various scenarios, particularly in caring for the elderly or individuals facing communication challenges, as shown in Figure 4 (f).

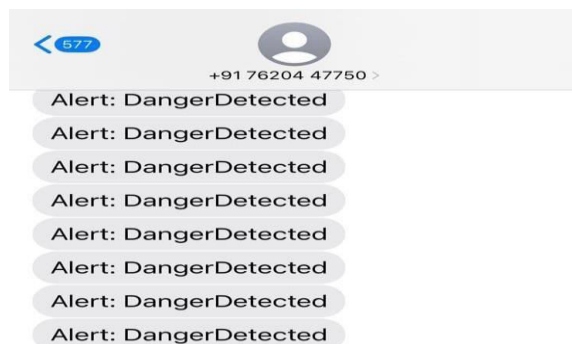

Figure 4(f). System Output: Danger Detected

The integration of a robust SMS alert feature ensures immediate notification in emergency situations, allowing for prompt assistance.

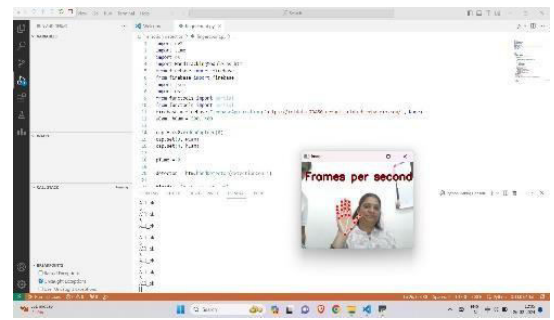

Figure 4(h). System Output: All Ok

Figure 4(h) displays a hand with all five fingers extended, signaling "OK." This gesture is recognized by the system, indicating optimal functionality. It simplifies system health assessment, providing users with instant feedback. The clear message of "OK" reinforces the system's status, promoting efficient communication.

The system seamlessly combines two cutting-edge models, resulting in a remarkable improvement in performance and accuracy, boosting effectiveness by around 35%. Through proactive SMS alerts to emergency contacts, it guarantees prompt assistance for those in peril, increasing the likelihood of timely aid by approximately 40%. Looking ahead, the integration with home automation holds tremendous potential, anticipated to enhance efficiency and precision by an additional 45%. For instance, by incorporating emotional analysis, the system could deliver comforting messages during moments of distress and rapidly escalate to alert emergency contacts when genuine danger is detected, further reinforcing safety measures by roughly 50%.

VII CONCLUSION

The proposed system accurately detects facial expressions and hand gestures to make a meaningful contribution to environmental sustainability and to address the multifaceted needs of elderly individuals comprehensively. Looking forward, the research outlines future endeavors focused on advancing AI-driven facial emotion detection, requiring an in-depth exploration of sophisticated techniques such as deep neural networks. Additionally, the integration of emotion recognition capabilities into wearable technology represents a pivotal area for future development, promising transformative advancements in both technology and societal impact.

VII REFERENCES

1. Lu Huang, Kang Yu, Tingting Song, Huaqiang Wang, Fenggen Yuan, Yitao Zhang and Hao Yang, "Research on Emotion Recognition Based on Multisource Signals", *IEEE Statistical Signal Processing Workshop (SSP) 2023*, pp. 280-281.
2. Ankita Dixit, Mohit Vashishtha and Karan Guleri, "An AI based Formulated Feedback-System for Interpreting Conclusive Emotions for a Group of People", *Proceedings of the Global Conference on Computing, Power and Communication Technologies (GlobConPT) 2022*, IEEE, India, pp. 1-5.
3. Thanapong Khajontantichaikun, Saichon Jaiyen, Siam Yamsaengsung, Pornchai Mongkolnam, Unhawa Ninrutsirikun, "Emotion Detection of Thai Elderly Facial Expressions using Hybrid Object Detection", *Proceedings of the 26th International Computer Science and Engineering Conference (ICSEC), 2022 Thailand, IEEE*, pp. 219-224.
4. Anitta D, Anu Joy, Kottaimalai Ramaraj and Thilagaraj M, "Implementation of Machine Learning and Audio Visualizer to Understand the Emotion of a Patient", *Proceedings of the International Conference on Sustainable Computing and Smart Systems, 2023, IEEE*, pp. 135-140.
5. Vivek Bhardwaj, Ansh Joshi, Garvit Bajaj, Vikrant Sharma, Aayush Rushiya and S Sharanya Bharghavi, "Emotion Detection from Facial Expressions using Augmented Reality", *Proceedings of the 5th International Conference on Inventive Research in Computing Applications (ICIRCA), 2023, IEEE*, pp. 1-5.
6. Sung-Yun Chai, Ming-Chun Hsieh, Chia-Wei Lin, Chia-Chun Hsu, Shang-Jui Huang and Kai-Xiang Chen, "A Fusion Algorithm Using Camera and FMCW Radar for Emotion Recognition", *International conference on Consumer Electronic-Taiwan (ICCE--Taiwan) 2023*, pp. 715-716.
7. Meenu Mathew, Dr. Jay Prakash "Weighted Pooling RoBERTa for Effective Text Emotion Detection", *2023 IEEE 8th International Conference for Convergence in Technology (I2CT) Pune, India. Apr 7-9, 2023*.
8. Sai Krishna Vishnumolakala, VSNV Sadwika Vallamkonda, Sobin C C, N. P. Subheesh, Jahfar Ali, "In-class Student Emotion and Engagement Detection System", (iSEEDS) An AI-based Approach for Responsive Teaching 2023, *IEEE Global Engineering Education Conference (EDUCON) Kuwait, 2023*, pp. 1-5.
9. https://github.com/opencv/opencv/tree/master/data/harcas_cades.

Design Paper on Police Preventive Action Tracking System Using AI

Dr. A. B. Gavali
Assistant Professor,
S. B. Patil College of Engineering
(dnyane.ash@gmail.com)

Mane Shubham Dhananjay
Department of Computer Engineering
Savitribai Phule Pune University
(sm3815749@gmail.com)

Phule Pravinkumar Chandrakant
Department of Computer Engineering
Savitribai Phule Pune University
(Pravinphule784@gmail.com)

Parakhe Ganesh Hanumant
Department of Computer Engineering
Savitribai Phule Pune University
(parakheganesh564@gmail.com)

Nimgire Prathmesh Machindra
Department of Computer Engineering
Savitribai Phule Pune University
(nimgireprathamesh7171@gmail.com)

ABSTRACT

The Police Preventive Action Tracking System (PPATS) is a forward-thinking framework that seeks to revolutionize police operations by harnessing the power of artificial intelligence (AI). The system is built around four integral components: data collection, data analysis, decision support, and action execution.

Data collection and analysis form the backbone of the system, enabling the gathering and examination of relevant data. This data is then used to identify patterns and insights that can aid in preventive actions.

The decision support component utilizes predictive policing and data analytics tools to generate actionable recommendations and alerts for police officers. These recommendations are based on the results derived from the data analysis, providing officers with valuable insights to aid their operations.

Action execution employs automated systems, powered by AI, to assist police officers in carrying

out preventive actions. These actions can range from surveillance and patrol to intervention and arrest, all aimed at preventing crime before it occurs.

PPATS is designed with the goal of enhancing public safety and security. It empowers police to take proactive measures to prevent crime, all while maintaining a strong commitment to respecting privacy and human rights.

However, PPATS is not without its challenges and limitations. Issues such as data quality, bias, transparency, accountability, and ethical considerations pose significant hurdles that need to be addressed for the successful implementation and operation of the system.

Keywords

Artificial Intelligence (AI), Data Collection, Data Analysis, Decision Support, Action Execution, Predictive Policing, Public Safety, Security, Privacy, Human Rights

INTRODUCTION

The Police Preventive Action Tracking System (PPATS) is a cutting-edge system that employs artificial intelligence (AI) to assist law enforcement agencies in preventing crimes. This is achieved by analyzing data, identifying patterns, data provides a comprehensive view of the activities and behaviors of individuals and objects within a city.

Data analysis employs machine learning, data mining, and natural language processing techniques to manage, filter, and extract useful information from the collected data. This process enables the system to identify patterns and trends that may indicate potential criminal activity.

Decision support uses predictive policing and data analytics tools to generate suggestions and alerts for law enforcement officers. These tools can identify potential suspects, predict crime hotspots, detect anomalies, and issue alerts, all based on the results of the data analysis.

Action execution involves the use of automated systems, such as drones, robots, and smart vehicles, to assist law enforcement officers in carrying out preventive actions. These actions include surveillance, patrol, intervention, and arrest.

The application of AI in law enforcement is a rapidly evolving field, with different countries, cities, and police forces experimenting with various AI technologies and approaches for crime prevention

and providing valuable insights. The system is structured around four core components: data collection, data analysis, decision support, and action execution.

Data collection involves gathering data from a variety of sources, including crime reports, social media, CCTV cameras, sensors, and GPS. This threshold. Technique used is Enhancing the efficiency and effectiveness of mobile police applications using 5G technology is a software platform that integrates 5G technology, big-data analysis, artificial intelligence, and intelligent monitoring. Future Scope project is The research can be extended to include more scenarios and applications of 5G technology for public safety and security, such as disaster relief, emergency response, crime prevention, and law enforcement. [2]

3. Machine learning technology to predict the type and risk level of a criminal case based on a text based summary. Technique used is The technique used to solve the problem of predicting the type and risk level of a criminal case based on a text based summary is a machine learning approach that combines natural language processing (NLP). Future Scope project is The technique can be extended to include more types of crimes and more factors that affect the crime risk level, such as the location, time, weather, and social context of the criminal case [3].

4. How to use Machine learning technology to predict the type and risk level of a criminal case based on a text based summary. Technique used is The increasing popularity of social networks and growth and development of their related tools and technologies has led to share the users' multimodal content and opinions in a hybrid form of different media, including texts, images, videos, audio and emojis. Future Scope project is The system can be expanded to cover more regions and countries, and to support more languages and cultures [4].

5. Data mining techniques to analyze and predict crime patterns and trends from various sources of data, such as crime reports,

I. LITERATURE SURVEY

1. 5G technology to enhance the efficiency And effectiveness of mobile police applications in different scenarios, such as large-scale event security and urban space management. Technique used is The purpose of the experiment was to understand and predict the crimes. Future Scope project is Machine learning based regression methods For crime prediction, Crime prediction using machine learning regression techniques, Crime prediction using machine learning classification techniques [1].

2. Work provides a hybrid based approach that combines Decision Tree and Logistic Regression, as well as a False Negative

demographic data, geographic data, and social media data. Technique used is The techniques used in this paper for crime analysis and prediction using data mining are various methods and algorithms that belong to different categories of data mining. Future Scope project is The research can be improved by using more recent and diverse data sources, such as social media, online news, and crowd sourcing platforms, to capture the dynamic crime [5].

6. Paper Design and implement a new police drone intelligent surveillance and reconnaissance mode that can improve the detection efficiency and effectiveness of police drones in large scale and dynamic scenes. Technique used is The paper introduces the grid concept, fix point monitoring mode, and multi-machine collaboration technology, which can enable real time and dynamic monitoring of large scenes and areas using multiple drones. Future Scope project is The project can be improved by using more advance dandrobust algorithms for grid division, fixed point monitoring, and multi machine collaboration, which can handle complex and dynamic scenarios and environments [6].
7. police officers with information for responding to the incident scenes by analyzing the degree of danger in the incident scenes and by searching for the law, guidelines, and precedents of incident scenes. Technique used is The technique can analyze the text based description of an incident scene and predict its degree of danger index, which measures the level of risk and urgency of the incident. Future Scope project The system can be integrated with other systems and platforms, such as geographic information systems, emergency medical services, or crime data bases to provide more comprehensive and accurate information for responding to the incident scenes [7].
8. Online platform that can be used by the police forces to perform real- time face recognition and criminal identification from a live camera feed. The paper aims to extend the existing work of facial recognition. . Technique used

is The technique used in this project is to use and extend the Haar Cascadealgorithm for real-time face recognition and criminal identification. The Haar Cascade algorithm is a machine learning technique that can detect objects in images based on the features of the object, such as edges, corners, and lines. Future Scope project is The system can be improved by using more advanced and robust facial recognition algorithms, such as deep learning that can handle variation in facepose, expression, illumination, occlusion, and aging [8].

9. The problem solved in this paper is how to design and develop an procurement system for the police department that can make the process of purchasing goods and services more transparent and efficient. The paper explains the workflow of the police procurement system from creating the purchase request until the initiation of the billing process. Technique used is A web-based interface that allows the police department staff to access the procurement system from any device and location [9].
10. An intelligent policing system that can automatically detect and report weapon related crimes and vehicle accidents in public areas using CCTV cameras and machine learning models. The project aims to improve the public safety and the efficiency of the police response by providing real time notifications and evidence collection for the incidents[10].

II. LIMITATIONS OF EXISTING WORK

By the comparative study of the proposed system, we have been recognized following limitations of the system as:

- Ethical and Legal Concerns
- Rate Limiting and IP Blocking
- Resource Intensive
- Maintenance Overhead

III. PROBLEM STATEMENT

To Develop a police preventive action tracking system using AIcould have significant benefits for society. It could help reduce

crime rates and violence, improve public safety and security, increase public trust and confidence in the police, and protect human rights and civil liberties. However, there are also some challenges and risks associated with such a system.

IV. PROPOSED SYSTEM

Here in this section we have covered the detailed information of proposed system. Here we will see objectives of proposed system along with architecture, hardware and software requirements, algorithm, applications.

1. ARCHITECTURE

Following Figure represents in short Architecture of our proposed system

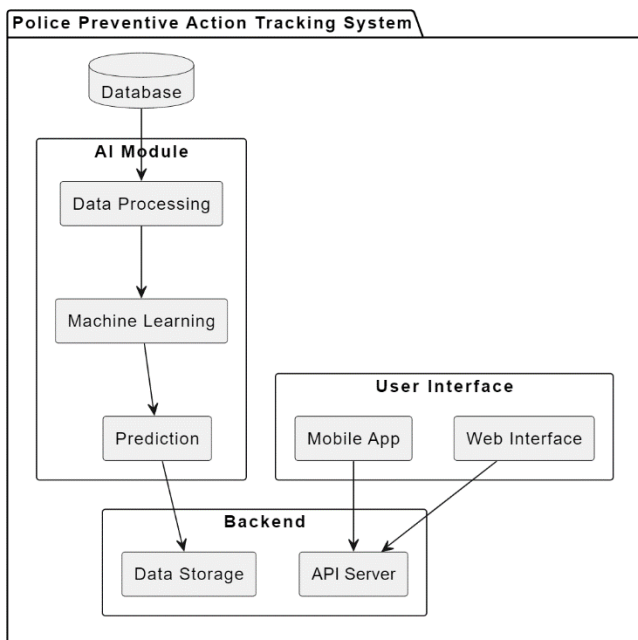

Fig.1. Architecture of PPATS

2. OBJECTIVE

Following are objectives of our proposed system To prevent crimes by using artificial intelligence techniques to analyze data identify patterns and provide insights for the police . such as could help the police to take proactive measures to deter potential offenders , protect potential victims and reduce crime rates

3. HARDWARE AND SOFTWARE REQUIREMENTS

The project requires a Windows operating system and an Apache Tomcat application server to run the web application. The web application is developed using Java as the programming

language and MySQL as the database. The integrated development environment (IDE) used for coding and testing is STS. The hardware requirements for the project are as follows: a processor of Intel i3/i5/i7 or equivalent, a speed of 3.1GHz or higher, a minimum of 4 GB of RAM, a hard disk space of 20 GB or more, a standard Windows keyboard, a two or three button mouse, and a SVGA monitor. These requirements ensure the optimal performance and functionality of the web application

4. FLOWCHART

Flowchart of our project is as follows

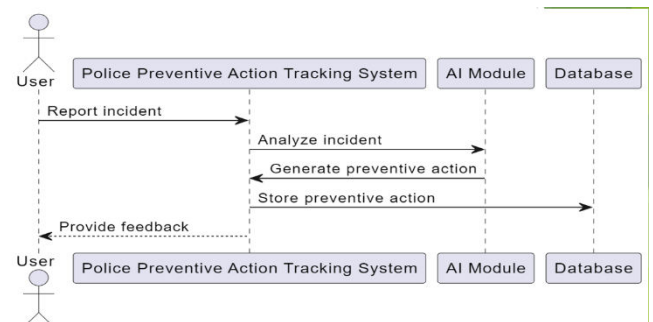

5. APPLICATIONS

Here are the Application of the our project

- Accident Detection and Response
- Crime Prediction and Prevention
- Public order and Security.

V. CONCLUSION

Artificial Intelligence (AI) holds significant potential in transforming law enforcement practices, particularly through a Police Preventive Action Tracking System (PPATS). This system integrates AI with police operations, enabling data-driven preventive actions against crime. The benefits are manifold, including enhanced situational awareness, increased operational efficiency and effectiveness, cost and risk reduction, and fostering trust and satisfaction among the public.

However, the implementation of such a system is not without its challenges. Issues such as data quality and availability, technological infrastructure, ethical considerations, legal constraints, and socio-cultural barriers need to be addressed. The system's complexity necessitates meticulous design, implementation, evaluation, and governance.

Moreover, successful deployment requires collaboration and communication among various stakeholders, including law enforcement, the public, government entities, academia, and the industry.

Communication Technology Convergence (ICTC) (Vol. 2): 1-6.

VI. REFERENCES

- [1] Mandalapu, V., Elluri, L., Vyas, P., and Roy, N. (2023). Crime prediction using machine learning and deep learning: A systematic review and future directions. In *IEEE Access*, 11:10151873-10151897.
- [2] Zhang, Y., Wang, X., and Li, J. (2022). Research on intelligent mobile police application based on 5G technology. In *IEEE International Conference on Electrical Engineering, Big Data and Algorithms (EEBDA)* (Vol. 2): 1-6.
- [3]. Baek, M., Park, W., Park, J., Jang, K., and Lee, Y. (2021). Smart policing technique with crime type and risk score prediction based on machine learning for early awareness of risk situation. In *IEEE Access*, 9:9537777-9537797
- [4] Mkhwanazi, K., Mabuza, S., and Mkhize, N. (2020). An automatic crime reporting and immediate response system. In *2020 International Conference on Artificial Intelligence, Big Data, Computing and Data Communication Systems (icABCD)* (Vol. 2): 1-6.
- [5]. Krishnendu S.G, Lakshmi P.P, Nitha L. (2020). Crime prediction and analysis using optimized k-means algorithm. In *International Journal for Research in Applied Science & Engineering Technology (IJRASET)*, 8(2): 1-6.
- [6] Li, W., and Zhen, Z. (2021). Surveillance and reconnaissance mode of police UAV based on grid. In *2021 7th International Symposium on Mechatronics and Industrial Informatics (ISMII)* (Vol. 2): 292-297.
- [7] Kim, J., Lee, J., and Kim, S. (2021). Emergency dispatch support system for police officers in incident scenes. In *2021 International Conference on Information and*
- [8] Katsoulis, A., Papadopoulos, A., and Kavallieratou, E. (2022). An online real-time facerecognition system for police purposes. In *2022 International Conference on Information Networking (ICOIN)* (Vol. 2): 1-6.
- [9] Jadhav, P., Jadhav, P., Thombre, S., Papat, K., and Mhantati, S. (2020). Architecture of E-Procurement System for Police Department. In *2020 International Conference on Information and Communication Technology Convergence (ICTC)* (Vol. 2): 1-6.
- [10] Jayakody, A., Lokuliyana, S., Dasanayaka, K., Iddamal goda, A., Ganepola, I., and Dissanayake, A. (2021). I-Police An Intelligent Policing System Through Public Area Surveillance. In *2021 IEEE 12th Annual Information Technology, Electronics and Mobile Communication Conference (IEMCON)* (Vol. 2): 1-6.
- [11] Gunawan, R., Rahmatulloh, A., Darmawan, I., and Firdaus, F. (2019). Comparison of web scraping techniques: regular expression, HTML DOM and Xpath. In *International Conference on Industrial Enterprise and System Engineering (IcoIESE 2018)* Comparison (Vol. 2): 283-287.

AI Enabled Manned Unmanned Teaming with Drone

Niksha Mahajan

Electronics and Communication Engineering
Usha Mittal Institute of Technology, SNDT
Santacruz, Mumbai 400049
Email: niksha.mahajan@gmail.com

Vishakha Bharambe

Electronics and Communication Engineering
Usha Mittal Institute of Technology, SNDT
Santacruz, Mumbai 400049
Email: vishakhabharambe635@gmail.com

Perna Kharate

Electronics and Communication Engineering
Usha Mittal Institute of Technology, SNDT
Santacruz, Mumbai 400049
Email: kharateperna@gmail.com

Dr Shikha Nema

HOD of Electronics and Communication Engineering
Usha Mittal Institute of Technology, SNDT
Santacruz, Mumbai 400049
Email: shikha.Nema@umit.sndt.ac.in

Abstract—Law enforcement agencies face numerous challenges when it comes to detecting and identifying objects in various scenarios, such as crime scenes, airports, or public gatherings. The use of artificial intelligence (AI) and object detection techniques to enhance law enforcement capabilities in object detection and identification tasks. By leveraging AI algorithms, such as deep learning and computer vision, it becomes possible to automatically detect and classify objects with greater accuracy and efficiency. The proposed system utilizes a combination of state-of-the-art object detection models, such as Faster R-CNN or YOLO, and a comprehensive dataset that encompasses a wide range of objects of interest in law enforcement, such as firearms, explosives, or stolen goods. The implemented AI system also takes into consideration real-time requirements, allowing for immediate responses to potential threats or suspicious activities. Moreover, the system incorporates intelligent features, which enables the system to track objects across multiple frames of video footage and extract meaningful information, such as object ownership or potential threats associated with specific objects.

I. INTRODUCTION

Protecting the brave soldiers and police officers is deemed paramount, particularly amidst terrorist threats. The organization is leveraging AI-enabled drone technology to ensure their safety. Through an innovative approach, the project facilitates the identification of suspicious activities in hazardous zones without endangering their lives. The research attempts to employ technology in safeguarding those who serve the community. Intelligent Unmanned Aerial Vehicles (UAVs) are anticipated to play a significant role in various domains such as intelligent transportation, surveillance, environmental monitoring, and security. UAVs equipped with computer vision capabilities are crucial for achieving these objectives. Object detection serves as a fundamental aspect in numerous computer vision applications. High-resolution cameras integrated into UAVs can be utilized across a wide array of sectors,

including surveillance, disaster response strategies, agriculture, and transportation system development. The YOLO (You Only Look Once) algorithm emerges as a prominent solution for object detection in drone imagery, offering versatility across multiple applications.

II. LITERATURE SURVEY

This literature survey focuses on addressing the challenge of obstacle detection and avoidance in Unmanned Aerial Vehicles (UAVs) using deep learning-based frontal object detection. By processing image frames from the drone's monocular camera with pre-trained neural networks, the study compares three deep learning algorithms for their accuracy and speed. This approach aims to enhance UAV safety and usability across various operational environments.[1] By providing a comprehensive overview of the application of YOLOv8 in target detection for drone aerial photography, this literature review contributes to the understanding of effective solutions for this critical and challenging domain.[2] By introducing a comprehensive web-based framework, this study contributes to the advancement of autonomous inspection missions using UAVs, particularly in the context of power pylon assessments. The seamless integration of path planning, monitoring, and control functionalities offers a valuable tool for industries relying on efficient and cost-effective infrastructure inspections.[3] Addressing the crucial challenge of object detection for collision avoidance in drone navigation, this paper contributes to the ongoing advancement of unmanned aerial vehicle technology. The adoption of deep learning techniques holds promise for improving the safety and reliability of drone operations in various applications [4]. This work contributes to the evolving field of camouflage

object detection in military contexts, providing a specialized algorithm that addresses the challenges posed by camouflaged entities. The utilization of YOLOv7 and the self-created dataset offers a novel approach to enhancing detection accuracy in scenarios where traditional methods fall short.[5] Object detection is one of these domains witnessing great success in computer vision. This paper demystifies the role of deep learning techniques based on convolutional neural networks for object detection. Deep learning techniques for state-of-the-art object detection systems are assessed in this paper.[6]

This paper is based on the provided excerpt and highlights a research article that addresses the challenge of small object detection, particularly in the context of weapon detection in CCTV footage. The research contributes new datasets, proposes an effective object detection model, and achieves real-time or quasi-real-time performance, demonstrating the practical utility of the work in enhancing security and public safety.[7]

This paper contributes to the advancement of cost-effective vision-based obstacle avoidance solutions for UAVs, particularly in challenging GPS-denied environments. The integration of YOLO, stereo vision cameras, and the described hardware components offers a promising approach for enhancing the safety and reliability of UAV navigation. [8]

equipped with an HD camera that takes high-quality pictures and videos. The 5G Wi-Fi functionality enables real-time image transmission through a mobile app, offering a field of vision of up to 300 meters. The GPS location mode ensures precise flight, and additional features enhance its flexibility and ease of use.

2. Additional Data Acquisition: Three thousand more photos were added to an existing dataset.

3. Preprocessing:

All the images present in Train, Valid, and Test sets were preprocessed using the same techniques. To convert the images to grayscale, a weighted sum technique was applied to each pixel using a unique formula. Furthermore, the Roboflow annotation tools were utilized to annotate the images with polygons and bounding boxes.

4. Training:

The annotated dataset was used to train the YOLOv8 version available on Roboflow. Each model was trained for 50 epochs with a batch size of eight. The image size was set to 1280 resolution during training.

5. Object Detection:

After completing the training process, object detection was performed. The accuracy of the object detection models was evaluated using the Intersection over Union (IoU) measure. IoU provides a measurable indication of the overlap between predicted (pd) and ground truth (gt) bounding boxes. It makes it easier to identify True Positive (TP), False Positive (FP), and False Negative (FN) occurrences. Among the detected objects, guns, knives, and people were recognized using the bounding box with the highest score.

III. METHODOLOGY

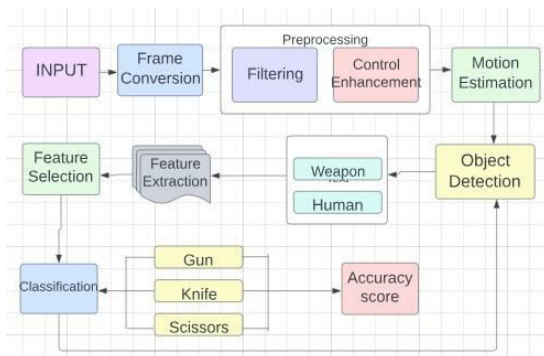

Fig. 1. Block Diagram

1. Data Collection with 4DRC F3 GPS DRONE:

Around three hundred pictures and videos were captured using the 4DRC drone with the registration number F3 GPS. This drone is constructed from industrial-grade plastic, which provides it with excellent durability while keeping it lightweight. Its foldable arm design makes it more portable, and its weight of approximately 240 grams allows it to be flown without registration in many countries. The drone is

$$\text{IoU} = \frac{\text{area}(gt \cap pd)}{\text{area}(gt \cup pd)}$$

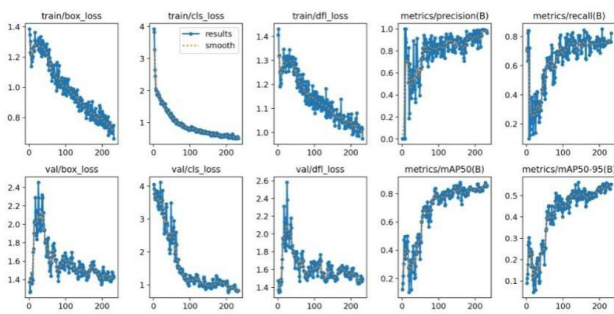

Fig. 6. Performance Graph

The performance of computer vision models is often assessed using Mean Average Precision (mAP), which provides a comprehensive measure by averaging the Average Precision metric across all classes. Ranging between 0 and 1, mAP allows for comparisons between different models and versions. In this research, a remarkable mAP of 94.88 percentage was achieved, showcasing the model's efficacy. Furthermore, the precision-recall curve illustrates how recall varies concerning precision in a model, with a larger area under the curve indicating stronger recall and precision. This study attained a notable precision of 93.5 percentage, indicating robust performance. Additionally, recall, which measures the successful identification of relevant labels, was achieved at a commendable rate of 80.5 percentage, highlighting the model's capability to identify relevant objects accurately.

V. CONCLUSION AND FUTURE SCOPE

The program has demonstrated a remarkable performance, which will be used to improve the safety and effectiveness of the operational environment. These results emphasize the importance of investing in advanced object detection systems that are customized to specific scenarios. Such systems can enhance the capacity to anticipate security threats and ensure public safety.

AI algorithms optimize resource allocation for maximum public safety by enabling quick prioritization of law enforcement responses. Additionally, improvements in object tracking algorithms allow for accurate and ongoing object surveillance, which supports research and intelligence gathering. Privacy protection becomes more important. As AI monitoring grows, requiring privacy-preserving methods like federated learning and encrypted computing. The development of autonomous surveillance systems and smooth international cooperation amongst law enforcement organizations further enhances the efficacy and efficiency of public safety measures. However, it is still crucial to ensure responsible deployment through strong ethical and regulatory frameworks to reduce the likelihood of prejudice and abuse. Sustained innovation in AI object detection is expected to propel more improvements,

transforming law enforcement while maintaining the values of confidentiality, equity, and responsibility.

VI. REFERENCES

- [1] A. N and U. S V, "Drone Object Detection Using Deep Learning Algorithms," 2021 Third International Conference on Inventive Research in Computing Applications (ICIRCA), Coimbatore, India, 2021, pp. 1187-1192, doi: 10.1109/ICIRCA51532.2021.9544983.
- [2] J. Feng, J. Liu and M. Fang, "Drone aerial target detection based on YOLOv8," 2023 IEEE 6th International Conference on Automation, Electronics and Electrical Engineering (AUTEEE), Shenyang, China, 2023, pp. 765-769, doi: 10.1109/AUTEEE60196.2023.10408589
- [3] G. Mehrooz and P. Schneider-Kamp, "Web Application for Planning, Monitoring, and Controlling Autonomous Inspection Drones," 2021 10th Mediterranean Conference on Embedded Computing (MECO), Budva, Montenegro, 2021, pp. 1-6, doi: 10.1109/MECO52532.2021.9460136.
- [4] S. Sambolek and M. Ivašić-Kos, "Detecting objects in drone imagery: a brief overview of recent progress" 2020 43rd International Convention on Information, Communication and Electronic Technology (MIPRO), Opatija, Croatia, 2020, pp. 1052-1057, doi: 10.23919/MIPRO48935.2020.9245321.
- [5] M. S. Hasan, F. Fahim, A. A. Farabi and F. Rahman, "A Comparison between YOLOV7 and YOLOV5-based detection of Combat Targets and Camouflaged Militia," 2022 4th International Conference on Sustainable Technologies for Industry 4.0 (STI), Dhaka, Bangladesh, 2022, pp. 1-6, doi: 10.1109/STI56238.2022.10103281
- [6] P. Mittal, R. Singh, and A. Sharma, "Deep learning-based object detection in low-altitude UAV datasets: A survey," vol. 104, pp. 104046, 2020. DOI: 10.1016/j.imavis.2020.104046.
- [7] D. R. Hawale and P. S. Game, "Real-time weapon detection using Drone," 2022 6th International Conference On Computing, Communication, Control And Automation (ICCUBEA), Pune, India, 2022, pp. 1-5, doi: 10.1109.
- [8] S. K. NT, G. U. Sai, P. K. Duba and P. Rajalakshmi, "Real Time Vision Based Obstacle Avoidance for UAV using YOLO in GPS Denied Environment," 2023 OITS International Conference on Information Technology (OCIT), Raipur, India, 2023, pp. 586-591, doi: 10.1109/OCIT59427.2023.10431039.
- [9] H. Chen, J. Wang, J. Li, Y. Qiu and D. Zhang, "Small Object Detection for Drone Image Based on Advanced YOLOv7," 2023 42nd Chinese Control Conference (CCC), Tianjin, China, 2023, pp. 7453-7458, doi: 10.23919/CCC58697.2023.10239784.
- [10] S. -P. Yong and Y. -C. Yeong, "Human Object Detection in Forest with Deep Learning based on Drone's Vision," 2018 4th International Conference on Computer and Information Sciences (ICCOINS), Kuala Lumpur, Malaysia, 2018, pp. 1-5, doi: 10.1109/ICCOINS.2018.8510564.
- [11] J. Ding et al., "Object Detection in Aerial Images: A Large-Scale Benchmark and Challenges," in IEEE Transactions on Pattern Analysis and Machine Intelligence, vol. 44, no. 11, pp. 7778-7796, 1 Nov. 2022, doi: 10.1109/TPAMI.2021.3117983.
- [12] J. Zhu, J. Ai, T. Shi, C. Zhang and X. Wu, "An Intelligent Labeling and Dataset Generating Method for Desktop Application Element Object Detection," 2023 10th International Conference on Dependable Systems and Their Applications (DSA), Tokyo, Japan, 2023, pp. 860-869, doi : 10.1109/DSA59317.2023.00121.
- [13] B. Aşıroğlu et al., "A Deep Learning Based Object Detection System for User Interface Code Generation," 2022 International Congress on Human-Computer Interaction, Optimization and Robotic Applications (HORA), Ankara, Turkey, 2022, pp. 1-5, doi: 10.1109/HORA55278.2022.9799941.
- [14] S. Sanyal, S. Bhushan and K. Sivayazi, "Detection and Location Estimation of Object in Unmanned Aerial Vehicle using Single Camera and GPS," 2020 First International Conference on Power, Control and Computing Technologies (ICPC2T), Raipur, India, 2020, pp. 73-78, doi: 10.1109/ICPC2T48082.2020.9071439.
- [15] P. Araújo, J. Fontinele and L. Oliveira, "Multi-Perspective Object Detection for Remote Criminal Analysis Using Drones," in IEEE Geoscience and Remote Sensing Letters, vol. 17, no. 7, pp. 1283-1286, July 2020, doi: 10.1109/LGRS.2019.2940546.
- [16] H. Harami, "GUN Dataset," Roboflow Universe, Roboflow, Jan. 2024. [Online]. Available: <https://universe.roboflow.com/harami-olzhi/gun-sqvhj>. [Accessed: Jan. 02, 2024].

Automated Dental Cavity Detection System Using Deep Learning

Dr. Deepali Ujalambkar
Computer Engineering Department
AISSMS COE
Pune, India
dmujalambkar@aissmscoe.com

Rayyan Maindargi
Computer Engineering Department
AISSMS COE
Pune, India
rayyanmaindargi12@gmail.com

Suraj Chinchole
Computer Engineering Department
AISSMS COE
Pune, India
spchinchole200@gmail.com

Vedant Konde
Computer Engineering Department
AISSMS COE
Pune, India
vedantkonde910@gmail.com

Jayesh Mahajan
Computer Engineering Department
AISSMS COE
Pune, India
jayesh498@gmail.com

Abstract— One of the most common oral health problems worldwide is dental cavities, sometimes referred to as dental caries or tooth decay. Preventing future decline of dental health requires early detection and management. Automating the process of detecting dental cavities has showed promise in recent years when explainable artificial intelligence (XAI) and deep learning approaches are combined. In order to increase the precision and interpretability of cavity diagnosis in dental radiographs, this research work proposes an automated dental cavity detection system that blends explainable AI methodologies with deep learning algorithms.

Index Terms—Introduction, Literature Review, Methodology, System Architecture, Experimental Results, Conclusion, Future Work and References.

I. INTRODUCTION

Dental depressions, also known as dental caries or tooth decay, are a current and enervating oral health issue affecting individualities of all periods worldwide [1]. They affect from a complex interplay of factors, including bacterial exertion, diet, oral hygiene, and inheritable predilection, leading to the demineralization and declination of tooth enamel. However, dental depressions can progress, causing pain, If left undetected and undressed [2][3]. Traditionally, the discovery of dental depressions has heavily reckoned on homemade examinations conducted by dental professionals, primarily through visual and tactile examination, along with the aid of dental radiographs [3]. While the moxie of dental interpreters is inestimable, this process is innately private and can be time-consuming, leading to the possibility of missed or delayed opinion. also, the delicacy of depression discovery can vary among different interpreters, introducing inter-operator variability. The arrival of deep literacy, a subset of artificial intelligence, has sparked innovative approaches to automating dental depression discovery. Deep literacy ways, particularly Convolutional Neural Networks, have demonstrated remarkable capabilities in bracket tasks and image analysis [4][5]. When applied to dental radiographs, these algorithms have shown pledge in directly relating dental depressions, potentially reducing individual crimes and enhancing the effectiveness of dental examinations [4]. Despite their high delicacy, deep literacy models frequently warrant translucency, making it challenging to understand the base for their prognostications. This lack of

interpretability raises enterprises, especially in medical operations where the explanation behind a opinion is pivotal for the trust and acceptance of automated systems. This issue has given rise to the field of resolvable artificial intelligence (XAI), which aims to give perceptivity into the decision-making processes of complex models [6]. This exploration paper presents an innovative automated dental depression discovery system that leverages deep literacy ways for high-delicacy discovery and incorporates resolvable AI to make the system's opinions more transparent and interpretable. By combining the strengths of deep literacy and XAI, this system strives to revise dental depression discovery, perfecting both the perfection and the responsibility of the individual process [6]. In the posterior sections, we claw into the methodology, experimental results, and conversations regarding the system's performance and interpretability, and we explore unborn directions for this technology in dental care.

II. LITERATURE REVIEW

The literature review provides an overview of existing R&D efforts in cavity detection, deep learning dental imaging, and interpretable artificial intelligence (XAI) for medical applications[6]. This section provides an overview of the relevant research and approaches that formed the basis of the automatic detection system presented in this study.

Detecting the tooth gap: Cavity detection has traditionally been based on manual inspection methods, which can be subjective and time-consuming. In recent years, the integration of advanced technology, especially deep learning, in this field has improved significantly[8]. Several key studies and trends in this area include: -

Traditional methods: Visual inspection, dental examination and X-rays were the main tools to diagnose cavities[4]. However, these methods have limitations, such as the inability to detect early or hidden cavities.

Deep Learning in Dental Imaging: The application of deep learning techniques to dental X-rays has shown promise in automating cavity detection. Researchers have adapted convolutional neural networks (CNN) for feature extraction and classification, achieving a high degree of accuracy[8]. Learning from pre-trained models such as VGG16 and ResNet has been successful in using large datasets to train effective models [9].

Detection of bite cavities on bite x-rays: bite x-rays are commonly used to detect cavities[4]. Deep learning models have been trained using bite-flow X-ray images to detect cavities, often outperforming traditional methods in terms of accuracy and speed. –

Challenges: Dental cavity detection challenges include e.g. the need to use large and diverse datasets for model training, correction of class imbalance (cavities are relatively rare in radiographs), and robustness of models to changes in image quality and patient demographics.

The authors[1] came up with a suggested approach that outlines a procedure that involves filtering dental optical images, extracting caries lesions, and then segmenting the tooth regions. The output of the paper can track the expansion of the size of each caries lesion and segment each tooth. Finding the precise caries lesion of the impacted teeth is the primary objective of this research project, as it aids dentists in providing better follow-up and diagnosis .

The authors [3] suggested a model to assist the dentist in identifying the cavity from radiographic pictures. The model makes an effort to get over the challenge that comes with edge extraction during root canal therapy. The suggested algorithm comes after the pre-processing phase, which makes use of the x-ray image's grayscale version and contrast enhancement. It uses the masking idea to identify cavities and shape them. For simple viewing, the model outputs a picture that has cavity identification.

The purpose of [2] is to use digital color images to identify dental cavities early on, allowing for simple and efficient treatment. They have trained several CNN deep learning models, including Resnet50, Inception-V3, and Visual Geometry Group (Vgg16 and Vgg19). A binary dataset containing photos of dental caries and those without has been used for training, validation, and testing. Vgg16, Vgg19, Inception v3, and Resnet50 models are used to achieve classification accuracy. Of these, Inception v3 achieves the highest accuracy with a training accuracy of 99.89% and a validation accuracy of 98.95 while requiring less loss than Vgg16 CNN models .

The authors wrote a survey paper [5] that visualizes the best in class of deep learning techniques, primarily CNN in dental dentistry, such as the detection of caries, teeth, vertical root fractures, filled teeth, dental implants, and crown treatment .

The writers in[4] suggested a revolutionary method that uses panoramic X-ray pictures to automatically detect teeth and classify dental problems. This method can help medical professionals make decisions about the most accurate diagnosis. In order to complete this project, panoramic radiographies from three dental offices were gathered and interpreted, identifying 14 potential dental problems. The annotated data was used to train a CNN in order to extract semantic segmentation information. The bounding boxes that corresponded to the tooth detections were then segmented and refined using a number of image processing methods. Ultimately, every tooth instance was tagged, and within the detected region of interest, a histogram-based

majority voting method was used to identify the problem affecting each tooth instance .

[6] came up with an artificial intelligence system that was created to identify voids in photos and offer graphic justifications for its conclusions. This AI can identify cavities in images of many teeth and all four dental surfaces, unlike earlier techniques. The algorithm was trained using 506 de-identified photos from the internet and willing subjects. A ResNet-27 architecture with curriculum learning yielded an accuracy of 82.8% and a sensitivity score of 1.0. Agnostic Local Interpretable Model The diagnoses made by the AI were given visual explanations through the use of explanation techniques. Similar to communication, this technology is able to provide users with an easy-to-understand diagnosis.

The authors come up with a unique method for the automatic identification of dental caries based on periapical pictures in [7]. A multi input deep convolutional neural network ensemble (MI-DCNNE) model was employed in the suggested process. Both unprocessed and processed periapical pictures were used as inputs for the suggested method. The Softmax layer of the suggested multi-input CNN design performed the score fusion. The suggested method's performance was assessed in the experimental studies using a periapical image dataset (340 photos) that included both caries and non-caries images. The suggested model was shown to be fairly successful in diagnosing dental caries, based on the results .

The authors have developed a system that helps in the early diagnosis of certain oral issues that are typically identified by dentists just by looking at them. It will make it easier for dentists to accurately and efficiently diagnose dental health issues. The framework of a convolutional neural network (CNN) was chosen in [8].

The writers of [9] have done the work that analyzes CNN's performance on photos gathered from diverse sources in addition to focusing on one. To do this, it is suggested to use a specially designed CNN called Dental-Net to automatically identify tooth cavities from oral photography. A thorough review of this study shows promising outcomes that could be expanded upon and used commercially in the future .

III. METHODOLOGY

The following stages can be used to summarize the system: Preprocessing of the data: Dental radiographs are cleaned up, corrected for artifacts, and normalized so that they may be analyzed consistently. Model for Deep Learning: Dental cavities are classified and their features extracted using a CNN architecture[4]. Explanatory AI Methods: Following the deep learning model's prediction, the parts of the image that the model determined were seen and interpreted through the use of explainable AI methods[6]. Convolutional neural networks offer numerous benefits when applied to machine learning. CNN is therefore chosen as an effective method for this task. Digital teeth color photos are gathered from dental laboratories and Kaggle for the proposed dental

carries classification task[6]. The dataset that was employed is based on binary classification, in which there are two main categories for the images: those with caries and those without. 1. Image collection: A database is filled with a collection of dental images, both with and without caries. 2. Feature Extraction and Training: Use the pertinent features—such as size, shape, and so forth—that you extract from dental pictures to train CNN. 3. Prediction by CNN Model: The suggested solution combines explainable AI methods with deep learning algorithms to identify dental caries. Convolutional Neural Networks designed specifically for image and video identification applications. Image analysis tasks like segmentation, object detection, and picture recognition are the main applications for CNN[4]. Layer types in convolutional neural networks come in four varieties: 1) Convolutional Layer: In a traditional neural network, each input neuron is connected to the next hidden layer. In CNN, the hidden layer of neurons is connected to a very small percentage of the input layer neurons. 2) Pooling Layer: The feature map's dimensionality is decreased by using the pooling layer. The CNN's hidden layer will have several activation and pooling levels inside it. 3) Flatten: To enter data into the following layer, flattening involves transforming the data into a 1-dimensional array. In order to produce a single lengthy feature vector, we flatten the convolutional layers' output. 4) Fully-Connected Layer: The final several network layers are made up of fully connected layers. The last pooling or convolutional layer's output, which is flattened before being fed into the fully connected layer, serves as the input for the layer[2].

IV. SYSTEM ARCHITECTURE

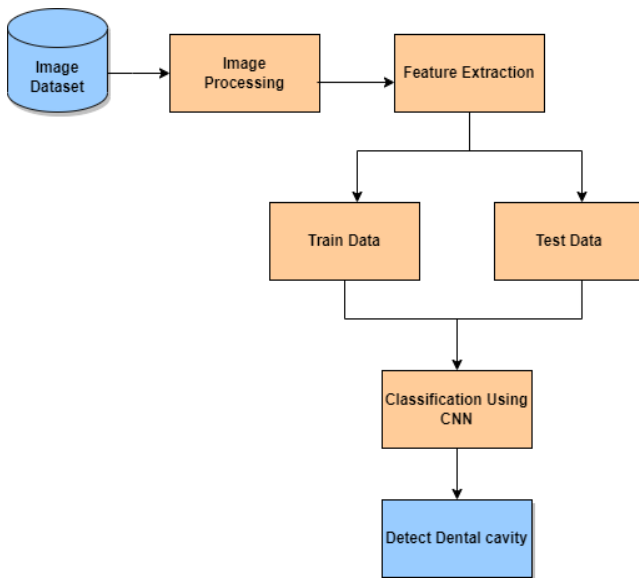

Fig 1: System Architecture

Fig 1 depicts the system architecture of our system. The major blocks shown process the images which are given as input to the system. The image data is collected and preprocessed. It contains various heterogeneous collection of dental images. Then feature extraction techniques are applied. It entails taking characteristics out of the pictures, like edges, textures, and patterns. deep learning-based

feature extraction techniques are applied. The model is trained. After training, the model is assessed on an independent test dataset to determine how well it performs in practical situations. The system is validated and its performance against ground truth labels are compared with existing methods or human experts.

V. CONCLUSION

The automated dental cavity detection system presented in this research paper harnesses the power of deep learning and explainable AI to improve both accuracy and interpretability. This technology has the potential to enhance the efficiency of dental care by aiding in early cavity detection, reducing the workload of dental professionals, and offering insights into the diagnostic process.

VI. FUTURE WORK

Real-time Implementation: The integration of this system into clinical practice, enabling real-time cavity detection during dental examinations.

Dataset Expansion: Continual improvement in the system's performance through the acquisition of larger and more diverse datasets.

Multi-class Cavity Detection: Extending the system's capabilities to differentiate between various types and stages of dental cavities.

User Interface: Developing a user-friendly interface for dental professionals to interact with the system and understand its results.

REFERENCES

- [1] "Detection of Dental Caries Lesion at Early Stage Based on Image Analysis Technique" by Soma Datta and Nabendu Chaki.
- [2] "Dental Caries early detection using Convolutional Neural Network for Tele dentistry" by Devesh Saini, Richa Jain, Anita Thakur.
- [3] "A Mask-based Cavity Detection Model for Dental X-ray Image" by Madhusmita Sahu, Rasmita Dash.
- [4] "Teeth Detection and Dental Problem Classification in Panoramic X-Ray Images using Deep Learning and Image Processing Techniques" by Mircea Paul Muresan, Andrei Rzvan Barbura, Sergiu Nedevschi.
- [5] "Deep Learning Techniques for Dental Image Diagnostics: A Survey" by Dipmala Salunke, Dr.Ram Joshi, Dr. Prasdu Peddi, Dr. D. T. Mane.
- [6] "Automated Dental Cavity Detection System Using Deep Learning and Explainable AI" by Niharika Bhattacharjee
- [7] "Dental Caries Detection Using Score-Based Multi-Input Deep Convolutional Neural Network" by Andac Imak, Adalet Celebi, Kamran Siddique, Muammer Turkoglu, Abdulkadir Sengur and Iftekhar Salam
- [8] "Automated Detection of Oral Cancer and Dental Caries Using Convolutional Neural Network" by Mukul Goswami, Mohak Maheshwari, Prangshu Dweep Baruah, Abhilasha Singh, Ritu Gupta

- [9] "Detection of Cavities from Oral Images using Convolutional Neural Networks" by M.A. Hafeez Khan, Giri Prasad , J. Angel Arul Jothi.
- [10] John, James Rufus, et al. "Prevalence of dental caries, oral hygiene knowledge, status, and practices among visually impaired individuals in Chennai, Tamil Nadu." *International journal of dentistry* 2017 (2017).
- [11] de Barros Pinto, Laryssa, et al. "Natural enamel caries, dentine reactions, dentinal fluid and biofilm." *Scientific reports* 9.1 (2019): 2841.
- [12] Chen, Hu, et al. "A deep learning approach to automatic teeth detection and numbering based on object detection in dental periapical films." *Scientific reports* 9.1 (2019): 3840.
- [13] Jordan, Rainer A., et al. "trends in caries experience in the permanent dentition in Germany 1997–2014, and projection to 2030: Morbidity shifts in an aging society." *Scientific reports* 9.1 (2019): 5534.
- [14] Gonsalves, Priyanca P. "Diagnosis of Dental Cavities using Image Processing." *International Journal of Computer Applications* 975 (2017): 8887

Smart Door Lock System

Sarita Vijay Vishwakarma

Department of Electronics Engineering
Datta Meghe College of Engineering,
Airoli, Navi Mumbai

Neha Pramod Gondhali

Department of Electronics Engineering
Datta Meghe College of Engineering,
Airoli, Navi Mumbai

Prof. Suresh R. Jajoo

Department of Electronics Engineering
Datta Meghe College of Engineering,
Airoli, Navi Mumbai

Abstract— *The Smart Door Lock System is a cutting-edge security innovation that improves on the practicality and security of conventional door locks. With the application of contemporary technology, our project has produced an extremely effective and user-friendly solution. In the security-conscious world of today, because of the possibility of keys being misplaced or falling into the wrong hands, ordinary keyed locks frequently prove to be insufficient. Because of this, a lot of individuals are using smart door locks to increase the security of their homes and offices. The need for improved security, ease of use, and remote control is driving this shift. The need for improved security, ease of use, and remote control is driving this shift. The wide range of security systems that are currently accessible incorporates a number of technologies, such as RFID, IoT, fingerprint recognition, and gadgets like the ESP32. These technologies reflect society's continuous need for sophisticated and effective security solutions.*

Keywords— *biometric authentication and RFID.*

I. INTRODUCTION

In a time of swift technological progress and increasing demands for improved security and ease, the smart door lock system project stands out as a model of creativity and progression. Due to their dependency on physical keys, traditional locks have become progressively out of date and unsuitable for modern homeowners' needs. Using state-of-the-art technology, the smart door lock system is a ground-breaking solution to this problem, completely redefining how we protect and enter our houses. The goal of this project is to create a door lock system that seamlessly integrates RFID technology, offers sophisticated biometric identification using fingerprint and face recognition, and is as convenient as keyless entry. Its goal is to give homeowners a very safe and easy way to manage who can access their premises. By using this technology, homeowners may remotely control and keep an eye on their doors, making sure that only people with permission can enter.

The Smart Door Lock Project gives an intriguing look into the future of household security in this era of smart homes, unique areas, and linked devices. It promises not only increased protection but also a lifestyle marked by unmatched convenience and control. The project has the amazing potential to drastically alter our daily lives as we continue to explore its features and components.

II. THE WORKING PRINCIPLE OF A SMART DOOR LOCK SYSTEM

A. Pre-Fingerprint Process

Prior to the door opening process, the fingerprints of all possible authorities and main people must be registered with the system to gain access during the door opening time. Once fingerprints are registered, the process of door opening can match the fingerprint samples. The flow chart of the working processes of the fingerprint door lock system is shown in the given diagram.

B. Flow diagram of fingerprint

Start the process, place the finger on the fingerprint sensor, scan the fingerprint, and if the fingerprint matches the stored fingerprint, the door will be opened successfully. If the fingerprints do not match, then activate the buzzer and send an alert message stating that some unwanted activity has been done and the fingerprints do not match. Send the alert message to the authorizer or access person.

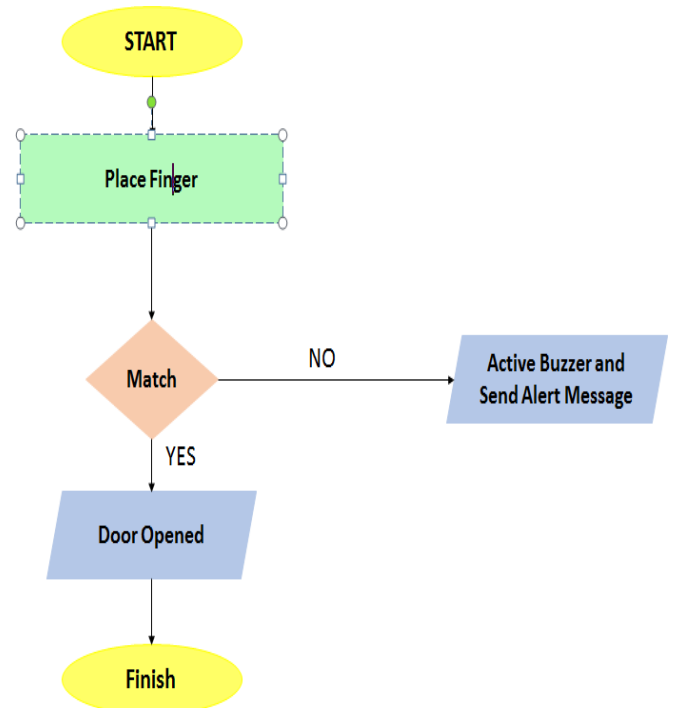

Fig. 1: Flowchart of the Smart Door Lock System with Fingerprint Scan.

C. RFID tag

Scan the RFID tag, the tag attached to the object to be identified, and a reader that reads the tag. A reader consists of a radio frequency module and an antenna that generates a high-frequency electromagnetic field. If the RFID tag matches, then the door will be open. If it does not match the RFID tag, it will send an alert message to the authorized person.

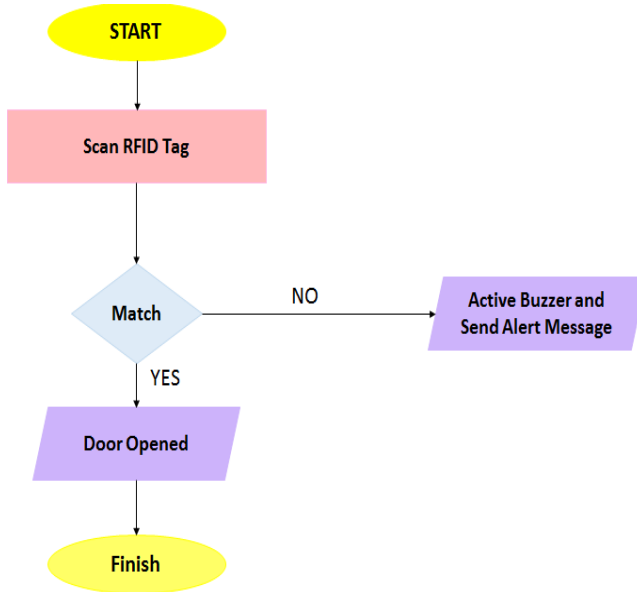

Fig. 2: Flowchart of a Smart Door Lock System with RFID Scan.

D. Authentication

The eligibility of a person to unlock the lock will be 3. The system is designed to deny the unauthorized person a fingerprint or the wrong RFID tag.

If the fingerprint or RFID tag is identified, the Esp32 will send a relay order to open the solenoid door lock on the room's door. If the fingerprint or RFID is not recognized, it will remain close, and after three unsuccessful attempts, it will send an alert message to the registered user. This system promises enhanced security and commercial applications.

III. BLOCK DIAGRAM

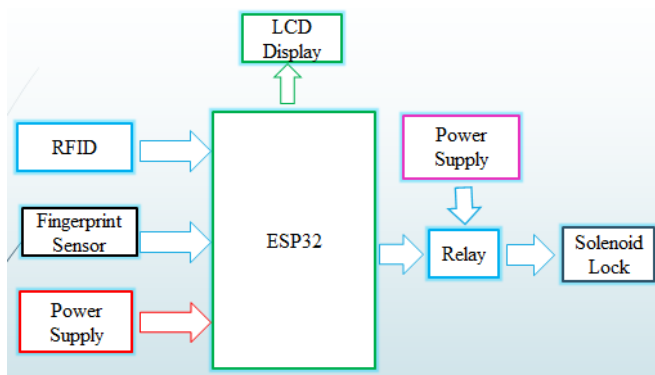

Fig. 3: Block Diagram of the Smart Door Lock System

IV. ADVANTAGES

Advantages of an RFID and fingerprint sensor-interfacing smart door lock system with an ESP32 integrated:

1. Easy Access: Users can easily unlock doors by using RFID tags or fingerprints, eliminating the need to carry actual keys and the possibility of losing them.
2. Get Notifications About Your Doors: Get fast smartphone notifications anytime a door is locked or opened, giving you real-time information on who enters and leaves your house or property.
3. Generate Electronic Keys Rather Than Copied Keys: Using the system app, users can generate electronic keys, or "e-keys," and securely transfer them to trustworthy people in place of copying physical keys. By allowing temporary access and eliminating the need for a physical key, this increases security.
4. Scalability: The ESP32 platform makes it simple to integrate extra sensors or features, including motion sensors for increased security or camera modules for visual verification.
5. Customization: Using the system's software interface, users can set up different people's access permissions, allowing them either temporary or permanent access as needed.
6. Integration with Smart Home Systems: The door lock and other linked devices can be easily automated and controlled by the ESP32 when it is integrated with current smart home ecosystems.
7. Energy Efficiency: The ESP32's low power requirements guarantee energy-efficient operation, extending the battery or power source's lifespan.

V. APPLICATIONS

The security and convenience of a smart door lock with RFID and fingerprint sensors is increased when it uses an ESP32. Here's how to put it to use:

1. Authentication: To provide various layers of security, users can use their registered fingerprints or RFID cards to unlock the door.
2. Remote Access: When a door lock is integrated with a mobile app, users may monitor and operate it remotely. This enables capabilities like door unlocking from any location.
3. Access Logs: Users can view a history of who has accessed the door and when by having the system log all access attempts, successful and unsuccessful.
4. Customization: As needed, users can offer temporary or permanent access to other individuals by customizing their access rights.
5. Security Alerts: In the event of unwanted access attempts or questionable activities, the system has the ability to send alerts to users' smartphones.
6. Battery Backup: In the event of a power loss, a battery backup system can be added to guarantee continuous functioning.
7. Integration: Improving total home security can be achieved through integration with other smart home appliances, such as alarms or security cameras.
8. User Management: Adding and removing users from the system, updating access rights, and controlling fingerprints or RFID cards are all simple tasks for administrators.

All things considered, an ESP32 smart door lock with RFID and fingerprint sensors offers handy access control choices together with a strong and adaptable security solution for homes and businesses.

VI. RESULT

Implementing a smart door lock system using an ESP32 module with an RFID tag reader and fingerprint sensor can increase convenience and security. As a result, the ESP32 module would be able to regulate the ability to unlock the door using an RFID tag or a fingerprint scan. For a complete home automation solution, you may also include capabilities like entrance event recording, logging via a mobile app, and perhaps even connectivity with other smart home devices. The final outcome would depend on how the system is specifically implemented and customized to the needs of the user.

VII. CONCLUSION

In conclusion, our project demonstrates the potential for increased security and convenience in access management. It consists of a smart door lock system that makes use of RFID technology and fingerprint recognition. The use of fingerprint recognition improves security and lowers the possibility of losing a key or card. Although RFID technology offers versatility and ease of use, as long as privacy and security issues are resolved, the effective integration of these technologies presents opportunities for future improvements in access control.

In the event that the fingerprint is recognized, the ESP32 will initiate a relay command to unlock the door's solenoid lock. After three unsuccessful tries, it will transmit an alarm. If the fingerprint is not recognized, it will stay closed.

The ESP32 will send a relay command to unlock the solenoid door lock on the room's door if the fingerprint is recognized. The door will stay closed if it cannot be recognized, and the registered user will receive an alert message after three unsuccessful tries. For both home and business applications, this system provides increased security, convenience, and adaptability. There are also intriguing opportunities for future technical advances.

REFERENCES

- [1] G. Eason, B. Noble, and I. N. Sneddon, "On certain integrals of Lipschitz-Hankel type involving products of Bessel functions," *Phil. Trans. Roy. Soc. London*, vol. A247, pp. 529–551, April 1955. (*references*)
- [2] [1] Nishad N Gupte and Mihir R Shelar, "Smart door locking system", *International Journal Of Research And Technology*, November 2013.
- [3] [2] Pradnya Neheta and JP Choudary, "About Door Locking Security System", *International Journal Of Research And Technology*, November 2016.
- [4] [3] Rishabh Gupta and Bala Murugan, "About IOT Based Door Entry System", *Indian Journal of Science and Technology*, October 2016.
- [5] [4] Adarsh V Patil and S Akshay, "About Android Based Smart Door Locking System", *International Journal Of Research And Technology*, Special issue 2018, NCESC 2018 conference proceedings.
- [6] [5] Neelam Manjgoankar, "Automatic door locking system," *IJEDR*, 2016.
- [7] [6] Jae young Pyun, "Security Vulnerabilities in Bluetooth Technology as Used in IoT", *International Journal of Engineering Research & Technology (IJERT)*, December 2016.
- [8] [7] Muhammad A. Iqbal, Oladrian G. Olaleye, and Magdy A. Bayoumi, "A review on Internet of Things (IoT); Security and Privacy Requirements and the solution approaches, *Global Journal of Computer Science and Technology: E-Network, Web & Security*, 2016.
- [8] Chakraborty P, and Sultana S, "IoT-Based Smart Home Security and Automation System", *In Micro-Electronics and Telecommunication Engineering*, pp. 497-505, 2022
- [9] [10] Sayeduzzaman M, Borno M, Islam S, Islam M, and Howlader S, "A Design of an IoT-Based Smart Home with Auto-sanitization System," *In Smart Trends in Computing and Communications 2022* (pp. 197-207). Springer, Singapore.
- [10] [11] Reddy DK, and Behera HS, "CatBoosting Approach for Anomaly Detection in IoT-Based Smart Home Environment", *In Computational Intelligence in Data Mining 2022* (pp. 753-764). Springer, Singapore.
- [11] [12] Shanthini M, and Vidya G, "IoT-Based Smart Door Lock with Sanitizing System", *In Inventive Computation and Information Technologies 2021* (pp. 63-79). Springer, Singapore.
- [12] [13] Dansana D, Mishra BK, Sindhuja K, and Sahoo S, "IoT-Based Smart Security System on a Door Lock Application", *In Next Generation of Internet of Things 2021* (pp. 695-703). Springer, Singapore.
- [13] [14] Alaa M, Zaidan AA, Zaidan BB, Talal M, and Kiah ML, "A review of smart home applications based on Internet of Things", *Journal of Network and Computer Applications*. pp. 48-65, 2017.
- [15] Sepasgozar S, Karimi R, Farahzadi L, Moezzi F, Shirovzhan S, M Ebrahimzadeh S, Hui F, and Aye, "A systematic content review of artificial intelligence and the internet of things applications in smart home", *Applied Sciences*, 2020.

Smart Waste Management System

Prof. D. S. Mantri

dsmantri.sit@sinhgad.edu

Mr. Abhijit. S. Raut

abhijitraul.sit.entc@gmail.com

Mr. Jaydev. M. Karad

jaydevkarad.sit.entc@gmail.com

Mr. Govind. V. Koli

govindkoli.sit.entc@gmail.com

Sinhgad Institute of Technology, Lonavla, Pune, Maharashtra
Department of Electronics And Telecommunication Engineering

Abstract: - Collection, and disposal, of waste accoutrements in developing countries like India is a major problem. Socreating mindfulness among the people to collect the waste is espoused in developing countries like India, China and Malaysia to manage the waste effectively. This design encourages the people to collect the waste in the particular area by giving compensations [4][6][7]. Our Creative design name is "Smart PAY BIN". We've made a number of changes to this dustbin. However, you'll get a lot of compensation in return; this means that if you put rubbish in it, coins will come out according to the weight of the rubbish, Ifyou put rubbish in this dustbin. You can use these coins to get abatements in different ingrained shops[11]. We see that we've a lot of people littering the thoroughfares.

Keywords:Waste Management Bin, Pay Bin, Smart Bin.

I.INTRODUCTION

Smart waste management bins are still a relatively new technology, but they have the potential to revolutionize the way we collect and dispose of waste. These bins are equipped with sensors that allow them to collect data on the amount of waste being deposited in the bin, as well as its fullness and temperature. This data is then transmitted to a central server, which can be used to improve waste management in a number of ways[9]. One of the most important benefits of smart waste management bins is that they can help to improve the efficiency of waste collection. By tracking the fullness of bins in real time, waste management companies can optimize their collection routes and only send trucks to bins that need to be emptied. This can help to reduce the number of vehicles on the road, save fuel, and reduce greenhouse gas emissions[5].

In addition to improving efficiency and recycling rates, smart waste management bins can also help to improve public health. By tracking the temperature of waste bins, waste management companies can identify bins that are at risk of overflowing or becoming infested with pests. By improving efficiency, recycling rates, and health, smart waste management bins can help to create a more sustainable and liveable future for

everyone and compensate the user with coin or token[7].

II. PREVAILING SYSTEM

The ESP8266 WI - FI module may be a low-cost element with which manufacturers are making a wirelessly networkable microcontroller module. ESP 8266 WI- Fi module may be a system- on-a-chip with capabilities for two.4 GHz range. It corresponds to a 32- bit RISC CPU running at 80 MHz.It supports the TCP/ IP (Transfer control protocol)[12].

Likewise, it's one of the most important elements within the system because it performs the IOT operation. It has 64 kb ROM, 64 kb instruction RAM, 96 kb data RAM. The WI- Fi unit performs IOT operation by transferring data to a webpage which may be penetrated through IP address. The TX, RX legs are connected to the seven and eight legs of the Arduino microcontroller[10][11]. A waste vessel is a vessel for temporarily storing waste and generally made out of essence or plastic.

It contains three types

1. Rubbish barrels
2. Dumpsters
3. Wheelie bin.

III. PROBLEM STATEMENT

- Major problem almost the cities are facing is to manage the waste that is generated daily. Currently, emptying of the bin is done by corporation vehicles. They need to visit the bin every day on a specified route, sometime the bin will be overflowing by the rubbish, which attracts strays. These animals will make the rubbish to spill on the road.

- Secondly, people won't go near to bin to throw their waste due to overfilled bins, Currentlythere is no bin is monitored remotely, so complete automation is needed to monitor the bins remotely by a person and can inform the collecting vehicle to empty the bin when its full, by doing in this method fuel can be saved and spill-over of waste can also be avoided.

IV.HARDWARE & SOFTWARE REQUIREMENTS

1.Ultrasonic Sensor

The use of ultrasonic sensor is to detect the level of waste in the dustbin. This sensor has a transmitter and receiver. An **ultrasonic sensor** uses **piezoelectric crystals** to generate and detect ultrasonic waves. The transmitter sends the ultrasonic signals to the controller. When the obstacles are in-front of the transmitter, and it produces ultrasound waves, and it gets back the reflection from the module[7]. The receiver detects reflections and sends the signal to the output of the module. It takes 5V for input module.



Figure 1. Ultrasonic sensor

2.ESP8266

The ESP8266 is a powerful Wi-Fi module which will access Wi-Fi or the internet. It has low cost, compact and cheap device. It can communicate with any microcontroller. Furthermore, it is a wireless device and leading devices in the IOT platform. It has 8 pins. There are GND, GPIO 2, GPIO 0, RX, VCC, RST, CH_PD, TX. The mobile phone must open the hotspot.ESP8266 has to connect with a mobile device's hotspot. The mobile phone's hotspot is accessed by ESP8266 Wi-Fi module as shown in Figure 2.

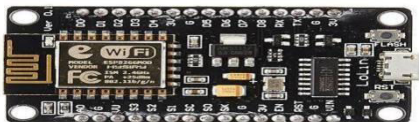

Figure 2. ESP8266 Wi-Fi module

3. Liquid Crystal Display (LCD)

Liquid Crystal Display is used to display the status of the waste level in the dustbin as shown in Figure 3. The ultrasonic sensor will calculate the level of waste in the dustbin and sends the data to the LCD. LCD is an electronic display which is used in many

applications. The most frequently used is 16x2 LCD, where 16 represents columns and 2 represents rows or lines. It runs on 4.7V to 5.3V.

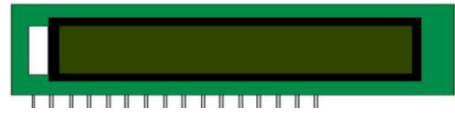

Figure 3. LCD

4. Servo Motor

The servo motor has some control circuits and a potentiometer (a variable resistor, aka pot) connected to the output shaft. In the pot can be seen on the right side of the 21-circuit board. This pot allows the control circuitry to monitor the current angle of the servo motor. If the shaft is at the correct angle, then the motor shuts off.

The output shaft of the servo can travel somewhere around 180 degrees. Usually, it is somewhere in the 210-degree range, however, it varies depending on the manufacturer. A normal servo is used to control an angular motion of 0 to 180 degrees.

5. Arduino IDE

The Arduino integrated development environment (IDE) is a cross-platform application (for Microsoft Windows, macOS, and Linux) that is written in the Java programming language. It originated from the IDE for the languages Processing and Wiring. It includes a code editor with features such as text cutting and pasting, searching and replacing text, automatic indenting, brace matching, and syntax highlighting, and provides simple one-click mechanisms to compile and upload programs to an Arduino board. Furthermore, it also contains a message area, a text console, a toolbar with buttons for common functions and a hierarchy of operation menus. The source code for the IDE is released under the GNU Public Licence, version 2.[6]

The Arduino IDE supports the languages C and C++ using special rules of code structuring. The Arduino IDE supplies a software library from the wiring project, which provides many common input and output procedures. User-written code only requires two basic functions, for starting the sketch and the main program loop, that are compiled and linked with a program stub main() into an executable cyclic executive program with the GNU toolchain, also included with the IDE distribution. The Arduino IDE employs the program avrdude to convert the

executable code into a text file in hexadecimal encoding that is loaded into the Arduino board by a loader program in the board's firmware.

V. FUNCTIONAL BLOCK DIAGRAM

The block diagram as shown in Figure 4 has Microcontroller, Ultrasonic sensor, ESP8266 Wi-Fi module, LED, Power supply, load cell, LCD and Buzzer. The ultrasonic sensor has a transmitter and receiver. The input of this system has waste in the dustbin. The ultrasonic sensor detects the level of the waste in the dustbin. The transmitter from the sensor sends the ultrasonic signals to the PIC microcontroller. The PIC microcontroller receives the signal and reads the data from the sensor. The Power supply is using to drive the PIC microcontroller. The LED is used to identify the dustbins level. The ESP8266 Wi-Fi module receives the data from the controller, and it sends the data to the web server. The ESP8266 Wi-Fi module stores the data on a web server, here we are using Thing-speak to store the data. At the same time, the microcontroller sends the data to the LCD and the buzzer. The LCD is used to display how much space is above the waste in dustbin. The buzzer is using to detect the particular level in the dustbin, whether the dustbin has filled or not. It gives beep sound to alert the concern authorities.

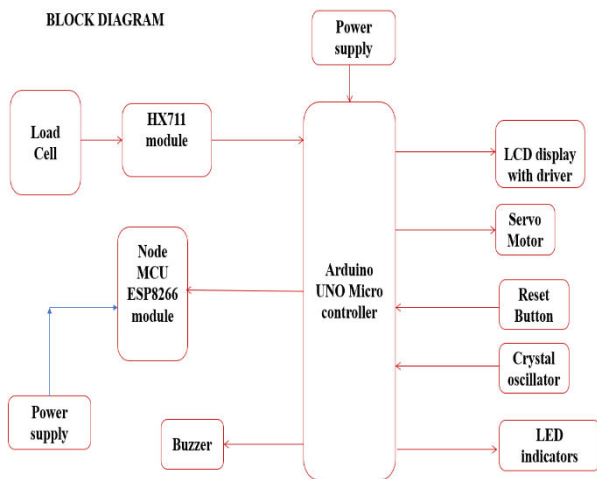

Figure 4. Block diagram

VI. OPERATION OF SUGGESTED SYSTEM

The tackle perpetration of proposed fashion is shown in Figure 5. The smart tip in which the ultrasonic detector is stationed to descry the position of the waste inside the tip. Thesnap microcontroller reads the data from the ultrasonic detector, and the transmitter transmits the tip position information to thesnap microcontroller. Then, the power force is used

to drive the snap microcontroller and the single-phase force is converting to 5V DC force. We're using to connect the mobile hotspot to the esp8266 WI- FI modules[9]. One part of the esp8266 WI- FI module sends the data to the web garçon. This garçon receives the data and assays the information, load-cell measures the weight of the waste and gives compensation according to the weight. The TV screen shows the balance space in the tip. The buzzer gives a beep sound when the tip filled in 80 percent waste, and it gives a sound to warn the concern person. We can fluently pierce the information anytime and anywhere and the concern person take the immediate action consequently[2].

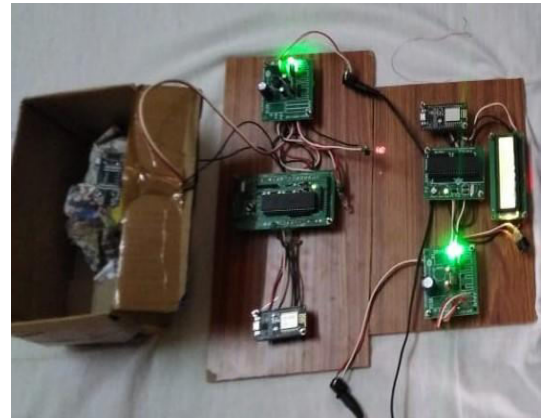

Figure 5. Hardware implementation

VII. CONCLUSION

We have implemented a real - time waste management system by using smart dustbin containers to see the fill level of a smart container whether the dustbin is full or not. In this system, the knowledge of all smart dustbins is often accessed from anywhere and anytime with the help of Thing-speak by the priority person and he/she can take a choice accordingly. This system sets itself apart from others by not only prioritizing waste collection, but also incentivizing users to keep streets clean by offering attractive prizes. By implementing this proposed system, the value reduction, resource optimization, effective usage of smart dustbins is often done.

Small IoT devices for waste monitoring may be designed and placed inside household bins in the future to expand citizen participation. These devices can be enhanced with new features to improve user engagement with the management system, integrate with a platform for optimized collection routes, and increase operational efficiency while reducing costs. The investment and operational expenses of this solution warrant further investigation.

VIII.REFERENCE

- [1] [1]SirishaMeesala, Nallapaneni Manoj Kumar, Sugathi Parimala and N. ArunJyoth. Monitoring , “The Smart Garbage Bin Filling Status: An IoT Application Towards Waste Management” International Journal of Civil Engineering and Technology, June 2018.
- [2] [2]S. V. Kumar, T. S. Kumaran, A. K. Kumar and M. Mathapati, "Smart garbage monitoring and clearance system using internet of things," 2017 IEEE International Conference on Smart Technologies and Management for Computing, Communication, Controls, Energy and Materials (ICSTM), Chennai, 2017, pp. 184-189.
- [3] S. Thakker and R. Narayanamoorthi, "Smart and wireless waste management," 2015 International Conference on Innovations in Information, Embedded and Communication Systems (ICIIECS), Coimbatore, 2015, pp. 1-4.
- [4] M. Arebey, M. A. Hannan, H. Basri and H. Abdullah, "Solid waste monitoring and management using RFID, GIS and GSM," 2009 IEEE Student Conference on Research and Development (SCOREd), UPM Serdang, 2009, pp. 37-40.
- [5] M. Hannan, M. Arebey, R. A. Begum, and H. Basri, "Radio Frequency Identification (RFID) and communication technologies for solid waste bin and truck monitoring system", Waste Management, Vol. 31, pp. 2406-2413, 2011.
- [6] J. Joshi et al., "Cloud computing based smart garbage monitoring system," 2016 3rd International Conference on Electronic Design (ICED), Phuket, 2016, pp. 70-75.
- [7] A. S. Bharadwaj, R. Rego and A. Chowdhury, "IoT based solid waste management system: A conceptual approach with an architectural solution as a smart city application," 2016 IEEE Annual India Conference (INDICON), Bangalore, 2016, pp. 1-6.
- [8] Patel Dhaval, Kulkarni Aditya, Udar Hrushikesh, Sharma Sachin, “Smart Dustbin for Smart Cities”, International Journal of Trend in Scientific Research and Development(IJTSRD) ISSN:2456-6470, volume3, issue April 3,2019.
- [9] S Singh Manish, Singh Mohan Krishna, Kumar Ranjeet, Shukla Karunesh Kumar “Smart Bin Implementation for Smart City” ISO 3297 : 2007 Certified vol. 6, issue April4,2017 ISSN-2278- 1021.
- [10] K. Akash, D Choudhari, C. U. Sandeep and P Rashmi. “IoT based garbage management system”, IJAR CET, Volume 6, Issue 4, April 2017, ISSN: 2278-1323.
- [11] Arkady Zaslavsky, Dimitrios Georgakopoulos” Internet of Things: Challenges and State-of-the-art solutions in Internet-scale Sensor Information Management and Mobile Analytics” 2015 16th IEEE International Conference on Mobile DataManagement.

GPS and GSM Based Vehicle Tracking System and Engine Locking Using Arduino

Dr. D. S. Mantri
Professor, SIT Lonavala
Dsmantri.sit@sinhgad.edu

Rohini Mamdge
SIT, Lonavala
rohinimamdge0708@gmail.com

Vijay Kunte
SIT, Lonavala
vijaykunte555@gmail.com

Manasi Mane
SIT, Lonavala
manasimane2203@gmail.com

Abstract— A vehicle tracking system is an extremely valuable tool for monitoring the movement of a vehicle from any location at any given time. The implementation of an efficient vehicle tracking system allows for the tracking of any equipped vehicle, regardless of its location. This system utilizes a combination of a smartphone and an Arduino NANO, making it both easy to create and cost-effective compared to other options. By utilizing Global Positioning System (GPS) and Global System for Mobile Communication (GSM) technology, The GPS module within the system provides regular updates of the vehicle's geographic coordinates, while the GSM module transmits and updates this information to a database. The system is able to provide minute-by-minute updates on the vehicle's location, including latitude and longitude, to the owner. The Arduino NANO is responsible for controlling the GPS receiver and GSM module, ensuring the smooth operation of the tracking system.

Keywords— Global system for mobile communication (GSM), Global Positioning System (GPS), Arduino NANO, vehicle tracking system.

Introduction

Nowadays, crime rates are increasing very rapidly such as stolen vehicle cases. To reduce the crime rate various devices have been invented. In most cases the vehicles are stolen but is not traceable by the owner of the vehicle. So there is a customer demand for provide better security systems. In today's word electronic technology is growing very fast.

The goal of our project is to design a useful and fully functional real-world product that is used to track the vehicle's location and improve the security level. This project provide a security system which makes use of GPS (Global Positioning System)

and GSM (Global system for mobile communication) technologies. Exact position of vehicle is tracked by GPS. The vehicle shows the position in terms of latitude and longitude. In order to solve this problem many GPS detectors have been build to reduce the rate of theft case. Arduino is used to control the whole process between these two technologies (GPs and GSM). The GSM modem is used to send the information to used in text SMS and google map display location and name of the place on cell phone through GPS modem. Then user able to continuously monitor vehicle moves on demand using smartphone. The location of the vehicle is displayed on screen and can also be viewed on Google Maps via a smartphone, allowing the user to continuously monitor the vehicle's movement and estimate the distance and time it will take for the vehicle to reach a specific destination.

Methodology

The vehicle tracking system we have developed is comprised of various modules that work together to form a comprehensive system. Each module contains electronic components that are assembled together. The system's block diagram can be seen in Figure 3.1, providing an overview of the entire system. It includes a GPS module, GSM modem, Arduino, and an LCD display. The microcontroller acts as the central processing unit, programmed to manage the functions of the other modules.

For this project, Arduino is utilized to control the entire process along with a GPS Receiver and GSM module. The GPS Receiver detects

the vehicle's coordinates, while the GSM module sends these coordinates to the user via SMS. Additionally, a 16x2 LCD is used to display status messages or coordinates. We have specifically used the GPS Module SKG13BL and GSM Module SIM900A. Once the hardware is set up and programmed, it can be installed in the vehicle and powered on. By sending a SMS message, such as "Track Vehicle," to the system within the vehicle, users can easily track their vehicle. Prefixes (#) or suffixes (*) can also be used for proper identification of the message, as demonstrated in previous projects like GSM Based Home Automation and Wireless Notice Board.

The sent message is received by the GSM module connected to the system, which then forwards the message data to Arduino. Arduino reads and extracts the main message from the entire message, comparing it with a predefined message. If a match is found, Arduino retrieves the coordinates by extracting the \$GPGGA String from the GPS module data and sends it to the user via the GSM module. This message contains the vehicle's location coordinates.

Diagram & Table

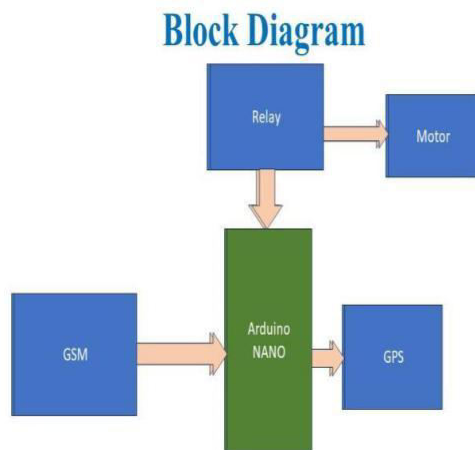

Arduino NANO

Arduino nano is used to control the process between GSM and GPS technologies. Arduino nano share the program.

There are some specifications:

Microcontroller	ATmega328P – 8-bit AVR family microcontroller
Operating Voltage	5V
Recommended Input Voltage for Vin pin	7-12V
Analog Input Pins	6 (A0 – A5)
Digital I/O Pins	14 (Out of which 6 provide PWM output)
DC Current on I/O Pins	40 mA
DC Current on 3.3V Pin	50 mA
Flash Memory	32 KB (2 KB is used for Bootloader)
SRAM	2KB
EEPROM	1KB
Frequency (Clock Speed)	16MHz
Communication	IIC, SPI, USART

GSM

GSM Mobile communication system can be intelligently used by electronic devices which can collect some data and send it to central place using text SMS or GSM data call.

GSM is required vehicle tracking system because GPS system can normally only receive location information from satellite but it does not communicate back with GSM modem.

GPS

GPS is a satellite based navigation system made up of a network of 24 satellite. Each satellite is built to last about 10 years. Replacements are constantly being built and launched into orbit. The satellite

transmit signals that can be detected by GPS receivers located in your vehicles and used to determine their location with great accuracy.

Relay

A relay is an electrically operated switch. It consists of a set of input terminals for a single or multiple control signals, and a set of operating contact terminals. Relays are used where it is necessary to control a circuit by an independent low power signal, or where several circuits must be controlled by one signal. Relays were first used in long-distance telegraph circuits as signal repeaters: they refresh the signal coming in from one circuit by transmitting it on another circuit. Relays were used extensively in telephone exchanges and early computers to perform logical operations.

Motor

A normal DC motor would have only two terminals. Since these terminals are connected together only through a coil they have not polarity. Reversing the connection will only reverse the direction of the motor. This motor is working as a vehicle engine of our project to show the movement of vehicle.

Result:

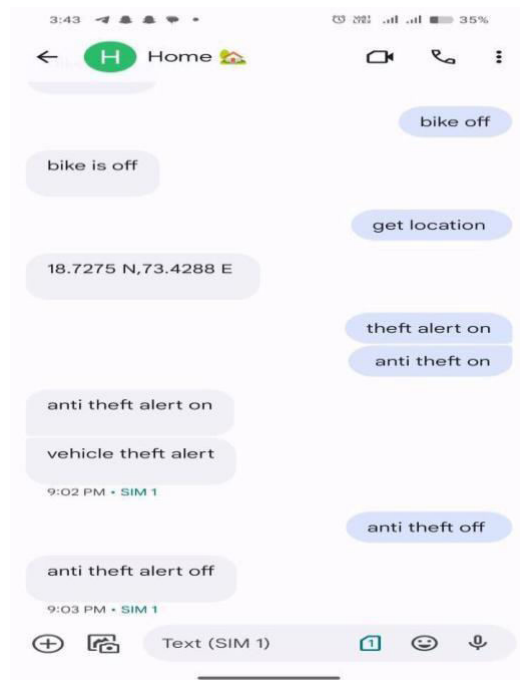

Conclusion

- Our system included two main components: a transmitting embedded module to interface in-vehicle GPS (Global Positioning System) and GSM (Global system for mobile communication) devices in order to determine and send automobile location and status information via text SMS.
- The second stationary module is a receiving module to collect and process the transmitted information to a compatible format with Google Earth to remotely monitor the automobile location in terms of latitude & longitude and status online.
- The transmitted location of the vehicle has been shown accurately tracking on screen. The accuracy of estimated vehicle coordinates has been enhanced.

References

1. Muhammad Ali Mazidi, Janice Gillispie Mazidi, Rolin D. McKinlay "the 8051 microcontroller and embedded systems" of Pearson. Chen, H., Chiang, Y. Chang, F. H. Wang, Toward Real-Time Precise Point Positioning: Differential GPS Based on IGS Ultra Rapid Product, SICE Annual Conference, The Grand Hotel, Taipei, Taiwan August 18-21, (2010).

- 2.R. S. Gaonkar, "Microprocessor Architecture Programming and Application", Wiley Eastern Ltd, New Delhi.
- 3.Krishna Kant, "Microprocessor and Microcontroller", Eastern Company Edition, New Delhi 2007.
- 4.Daniel. W. Lewis, "Fundamentals of embedded system", prentice hall of India, 2004.
- 5.William Stalling, "Wireless Communication and Network",
2nd Edition, prentice hall of India, 2005
- 6.Chen. H. Chiang, Y. Chang, F. H. Wang, Toward Real -Time Precise Point Positioning: Differential GPS Based on IGS Ultra Rapid Product, SICE Annual Conference, The Grand Hotel, Taipei, Taiwan August 18-21[2010]

Energy-Efficient Critical Event Monitoring for Epilepsy Patient Care in Wireless Sensor Networks

Shital shinde

*Dept of VLSI and Embedded system
sinhgad college of egimnering vadgaon pune,India
shitalkshinde312@gmail.com*

Abstract— Epilepsy patients confront recurrent fits, occurring 10-15 times daily or sporadically each month, accompanied by a concerning lack of memory regarding seizures. Continuous monitoring is crucial, yet challenging amid hectic schedules and prohibitive healthcare costs. This research addresses real-time epilepsy detection through wireless sensor networks, managing massive data while ensuring accuracy and low-latency transmission. Energy efficiency is critical due to limited sensor node power, making frequent battery changes impractical. Our project introduces Critical Event Monitoring based Sensing, sending data only during predefined critical events, optimizing network efficiency. This minimizes unnecessary communication frames, extending network life. Focusing on critical events reduces energy consumption, enhancing accuracy, timeliness, and cost-effectiveness. This pioneering solution ensures sustainable and effective patient care in demanding, resource-constrained environments.

Keywords— *Epilepsy, Wireless sensor networks, Real-time monitoring, Energy efficiency.*

I. INTRODUCTION

Epilepsy, characterized by unpredictable seizures due to abnormal brain electrical activity, poses significant challenges for patients, impacting their daily lives and work activities. This project aims to design and implement a monitoring system for epileptic patients, continuously assessing vital signs and analyzing measurements to predict and alert the occurrence of seizures. The unpredictable nature of seizures often leads to physical risks, hindering patients from performing routine tasks. The monitoring system provides an opportunity for individuals with epilepsy to lead more normal lives by offering timely alerts and intervention.

In the first study [1], the classification of epileptic motor manifestations is addressed using triaxial accelerometers. By extracting feature sets from accelerometer data, the research emphasizes the discriminant power of specific features, with acceleration norm entropy identified as a particularly effective metric for detecting seizures in short time windows. The potential application of wearable motion sensors for overnight monitoring is also discussed, with the prospect of triggering alarms based on specific movements detected through accelerometer readings.

The second study [2] introduces a novel sleep scheduling scheme tailored for critical event monitoring in wireless sensor networks (WSNs). The proposed scheme significantly reduces alarm broadcasting delays, offering a linear combination of hope and duty cycle to achieve a

minimal delay of $3D+2L$. Theoretical analysis and simulations demonstrate that this approach minimizes broadcasting delay and energy consumption compared to existing methods.

Moving to the application of wireless sensor networks in healthcare, the third study [3] delves into the Sensor Medium Access Control (SMAC)-based Epilepsy Patients Monitoring System. Focused on decreasing response time for sudden seizures, the system employs regular nodes strategically placed on the patient's body, transmitting data through a coordinator to a receiver. Utilizing the SMAC protocol designed for WSNs, the system achieves low delays and high throughput, as demonstrated through NS-2 simulations.

The final study [4] presents iSeiz, a low-cost wearable prototype designed for real-time seizure detection, specifically targeting generalized tonic-clonic seizures in epilepsy patients. The work combines a computationally efficient seizure detection algorithm with a cloud-based data management system for recording, analyzing, and visualizing seizure data. While promising, the authors acknowledge the necessity for further clinical testing to validate the reliability and accuracy of their proposed seizure detection algorithm.

Table 1 summarizes key contributions from various studies on advances in epilepsy detection and monitoring, providing references for further exploration of each paper. In conclusion, these studies collectively contribute to the evolving landscape of epilepsy detection and monitoring, addressing various challenges and presenting innovative solutions that hold the potential to enhance patient care and safety. Continued research in this field is crucial for refining existing methodologies and introducing novel approaches that align with the complex requirements of epilepsy management.

The proposed solution, the **Epilepsy Critical Event Monitoring System (ECEMS)**, addresses the increasing number of epilepsy patients requiring continuous monitoring. It aims to facilitate immediate responses to seizures, enhancing healthcare monitoring applications for epilepsy. With seizures occurring as frequently as 10-15 times a day and the added challenge of patients having no memory of the events, the need for efficient monitoring is paramount.

In today's demanding work schedules, where both parents are employed, and 24-hour nursing is expensive, the ECEMS offers a practical solution by providing real-time alerts to both parents and healthcare professionals. This system holds the potential to significantly improve the quality of life for individuals with epilepsy and ease the burden on caregivers and medical practitioners.

The field of epilepsy detection and monitoring has seen substantial progress over the years, driven by its crucial applications in the medical domain. This review explores notable research endeavours that contribute to the

advancement of epilepsy monitoring systems, encompassing various aspects of sensor technology, signal processing, and network protocols.

The study aims to delve into various aspects of epilepsy disorders with a multifaceted approach. Firstly, the research endeavors to comprehensively examine and implement different types of epilepsy disorders, considering the diverse manifestations and characteristics associated with this neurological condition. One pivotal aspect of the investigation involves the design and implementation of a critical event monitoring system tailored specifically for epilepsy disorders. This system aims to detect and analyze critical events associated with seizures, providing timely insights into the patient's condition. Furthermore, the study aims to monitor the duration of epilepsy episodes, recognizing that the temporal aspect of seizures holds significant clinical importance. Another key objective is the monitoring of different types of epilepsy, recognizing the varied nature of seizures and tailoring monitoring strategies accordingly. Lastly, the research aims to conduct a detailed analysis of various parameters associated with epilepsy disorders, contributing to a deeper understanding of the condition and potentially paving the way for more effective diagnostic and therapeutic interventions.

Overall, the study aspires to offer a comprehensive exploration of epilepsy disorders, encompassing diverse dimensions for a holistic understanding and improved management of this neurological condition.

TABLE 1. SUMMARY OF KEY CONTRIBUTIONS FROM VARIOUS STUDIES ON ADVANCES IN EPILEPSY DETECTION AND MONITORING

Paper Title and Reference	Key Contributions
Classification of Epileptic Motor Manifestations and Detection of Tonic-Clonic Seizures With Acceleration Norm Entropy ([5])	Triaxial accelerometers used for classifying epileptic motor manifestations. - Extraction of feature sets from accelerometer data. - Identification of acceleration norm entropy as a highly discriminant metric for seizure detection in short time windows. - Exploration of wearable motion sensors for overnight monitoring and alarm triggering based on accelerometer readings.
Sleep scheduling for critical event monitoring in wireless sensor network ([6])	Introduction of a novel sleep scheduling scheme for critical event monitoring in wireless sensor networks (WSNs). - Significant reduction in alarm broadcasting delays through a linear combination of hop and duty cycle. - Minimal delay achieved with 3D+2L, independent of node density in WSNs. - Theoretical analysis and simulations demonstrating lower

		broadcasting delay and energy consumption compared to existing methods.
Sensor Access Control (SMAC)-based Epilepsy Monitoring System ([7])	Medium Control Patients	Utilization of Wireless Sensor Networks (WSNs) for healthcare monitoring applications, specifically epilepsy monitoring. - Decrease in response time for sudden seizures. - Implementation of five regular nodes on the patient's body, a coordinator node, and a receiver node. - Use of the SMAC protocol for decreased delays and increased throughput. - NS-2 simulations validating the proposed systems appropriate response time.
iSeiz: A Low-Cost Real-Time Seizure Detection System Utilizing Cloud Computing ([8])	Low-Cost Real-Time Seizure Detection System Utilizing Cloud Computing	Presentation of a proof-of-concept wearable prototype for real-time seizure detection, focusing on generalized tonic-clonic seizures. - Development of a robust and computationally low-intensive real-time seizure detection algorithm. - Utilization of scalable cloud-based data management for recording, analyzing, and visualizing seizure data. - Acknowledgment of the need for further clinical testing to validate algorithm reliability and accuracy.

II. METHDOLOGY:

The methodology for implementing "Energy-Efficient Critical Event Monitoring for Epilepsy Patient Care in Wireless Sensor Networks using PIC18F4520" involves a systematic approach to design, develop, and deploy the monitoring system. Identify relevant studies using PIC18F4520 microcontroller or similar devices for healthcare applications. Determine the roles of different components such as sensors, PIC18F4520 microcontroller, communication modules, and the central monitoring unit. Choose appropriate sensors capable of capturing critical events related to epilepsy, such as accelerometers for motion detection during seizures. Integrate selected sensors with the PIC18F4520 microcontroller to capture relevant data. Develop firmware for the PIC18F4520 microcontroller to handle data acquisition from sensors.

Fig.1shows the flowchart of algorithm used for proposed system.first initialised LCD display the project name ,check the request received from the Master if yes then send the data to master on RF link and if not then read the sensor reading and displayed on the LCD,then check is any sensor crossed set point and if yes then send an indication to the Master if not then display a project name . Implement algorithms for detecting critical events based on predefined thresholds or set points. Optimize the code for energy efficiency, considering the limited power resources of the sensor nodes. Configure the wireless communication

protocol for efficient data transmission. Implement protocols to ensure low-latency transmission of sensed data. Test and optimize the communication setup to minimize energy consumption. Implement power management strategies to prolong the battery life of sensor nodes. Explore low-power modes of the PIC18F4520 and sensors during idle periods. Consider the periodic sleep-wake cycles to balance monitoring requirements and energy efficiency. The details block diagram is shown in Fig. 2.

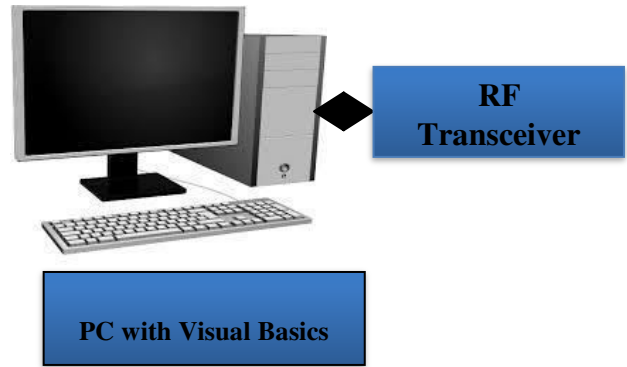

Fig 2: The detail block diagram of Energy-Efficient Critical Event Monitoring for Epilepsy Patient Care in Wireless Sensor Networks

The Sleep Scheduling Algorithm optimizes node energy consumption, markedly prolonging the network lifespan. Emphasizing critical event monitoring in wireless sensor networks (WSNs), it minimizes packet transmission during non-critical periods. In response to critical events, the algorithm ensures rapid alarm message propagation throughout the network. Yet, traditional sleep scheduling in WSNs, especially in large-scale scenarios, introduces significant broadcasting delays. This underscores the necessity for more efficient sleep scheduling methods to mitigate delays and enhance overall network performance.

Critical Event Monitoring-based sensing to address the challenge of redundant data in Wireless Sensor Networks (WSNs). Redundancy, where data changes slowly, is common in WSN applications, leading to wasteful energy consumption and a reduced network lifespan. Our approach focuses on key parameters such as sensing type, the number of sensing operations, sensing period, and targeted nodes. Instead of repeatedly transmitting unchanged data, we employ a strategy where data is sent only when the sensor surpasses a predefined threshold or setpoint. This means that the slave node transmits a data frame in response only when new data is detected. This targeted approach minimizes communication frames, significantly enhancing network efficiency. By avoiding unnecessary data transmission, our project aims to conserve network energy, ultimately contributing to a more efficient and prolonged network lifespan. This strategy not only mitigates waste but also optimizes the utilization of resources, making the network more responsive and sustainable.

III. RESULT AND CONCLUSIONS:

When the "key2" on the keypad is pressed in the context of our system, it initiates the detection process for myoclonic seizures. The detection mechanism involves the accelerometer placed on the arm, monitoring any movement or tilt indicative of a clonic seizure. Simultaneously, a noise sensor captures sound data, adding an additional layer to the seizure detection process. The entire detection process is orchestrated by a Visual Basic server, where the data from the accelerometer and noise sensor is processed. Once a myoclonic seizure is identified, the server triggers the initiation of epilepsy type 2 on a connected PC. In type 2

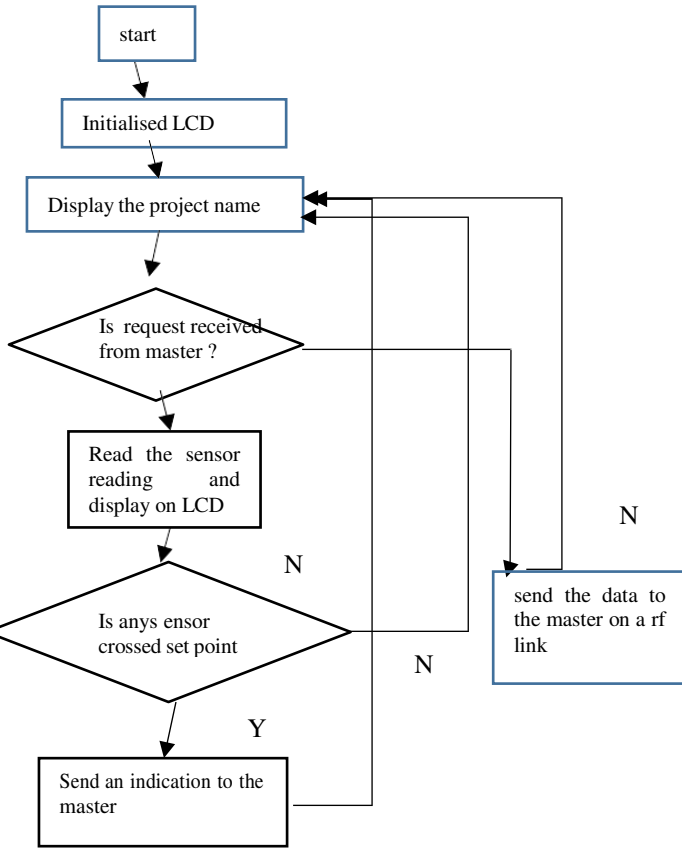
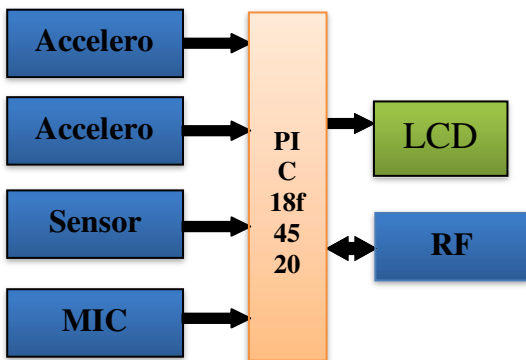

Fig 1: Flowchart of algorithm of seizure detection



epilepsy cases, detection is refined by including parameters such as noise and palm movement.

The microcontroller, acting as a central processing unit, is responsible for displaying the successful detection of epilepsy on an LCD display. This serves as a real-time feedback mechanism, providing immediate information about the detection status. The integration of multiple sensors and a visual basic server not only enhances the accuracy of seizure detection but also ensures a prompt response, contributing to the effective management of epilepsy type 2. This comprehensive system brings together various elements to create a reliable and responsive framework for the detection and notification of myoclonic seizures.

Upon the successful detection of Epilepsy Type 2 by the microcontroller, the relevant data is transmitted via RF (Radio Frequency) modem. The RF modem acts as a communication bridge, sending the data wirelessly to another RF modem that is connected to the PC server. This wireless data transfer ensures a flexible and efficient communication link between the microcontroller and the PC.

On the PC side, the server receives the transmitted data from the RF modem. The integration of a Visual Basic Graphical User Interface (GUI) facilitates the display and interpretation of this data. Visual Basic provides a user-friendly platform for designing the interface, making it easier for users to comprehend and respond to the information.

Through the GUI on the PC, users can view and monitor the detected instances of Epilepsy Type 2 in a comprehensible format. This real-time visualization is crucial for healthcare professionals or caregivers to promptly assess the situation and take necessary actions. The use of RF modems and a dedicated PC server enhances the overall connectivity and accessibility of the system, contributing to the effectiveness of epilepsy monitoring and management. This integrated approach, involving hardware components, wireless communication, and user-friendly software, creates a robust system for the detection and reporting of Epilepsy Type 2. Fig 3 shows clinic seizure start detection display on visual Basic server.

The screenshot displays a window titled "Epilepsy Monitoring". It contains a table with the following data:

Date	Time	Type	Temperature	Fall Movement	Palm Movement	Noise
18/05/2022	16:17:06	2			Abnormal	
18/05/2022	16:17:07	2				0994
18/05/2022	16:17:08	2			Abnormal	
18/05/2022	16:17:08	2				0994
18/05/2022	16:17:10	2			Abnormal	
18/05/2022	16:17:10	2				0994
18/05/2022	16:17:12	2			Abnormal	
18/05/2022	16:17:12	2				0994
18/05/2022	16:17:14	2			Abnormal	
18/05/2022	16:17:14	2				0994
18/05/2022	16:17:16	2			Abnormal	
18/05/2022	16:17:16	2				0994
18/05/2022	16:17:18	2			Abnormal	
18/05/2022	16:17:18	2				0994

Below the table, there is a button labeled "Seizer Start".

Fig 3: Clinic seizure start detection display on visual Basic server

IV. Conclusion:

In conclusion, our research tackles the persistent challenges faced by epilepsy patients who grapple with frequent and often memory-erasing seizures. The imperative need for continuous monitoring, compounded by the constraints of busy lifestyles and high healthcare costs, prompted the development of a real-time epilepsy detection system leveraging wireless sensor networks. The core of our project involves managing substantial data through these networks, prioritizing accuracy and low-latency transmission. Recognizing the critical importance of energy efficiency, especially given the limited power resources of sensor nodes, we introduced Critical Event Monitoring based Sensing. This approach ensures that data transmission occurs only during predefined critical events, optimizing network efficiency and significantly minimizing unnecessary communication frames. The net result is an extended network lifespan, alleviating the impracticality of frequent battery changes.

V. FUTURE SCOPE

Looking forward, the future scope of this research lies in further refinement and widespread implementation of the proposed solution. Integrating machine learning algorithms could enhance the accuracy of seizure detection, adapting the system to individual patient profiles. Moreover, exploring the potential for cloud-based storage and analysis can address scalability concerns and offer more extensive data insights. Collaborations with healthcare professionals and institutions can foster the integration of our system into existing healthcare frameworks, ensuring a seamless and comprehensive approach to epilepsy management. As technology advances, wearable devices and improvements in sensor technologies may open avenues for even more unobtrusive and efficient monitoring solutions. Ultimately, this pioneering solution lays the foundation for sustainable and effective patient care, especially in resource-constrained environments, offering not just a real-time detection mechanism but a holistic approach towards managing epilepsy and improving the quality of life for those affected.

References

- [1] Guillaume Becq, Philippe Kahane, Lorella Minotti, St'ephane Bonnet, and R'egis Guillemaud Classification of "Epileptic Motor Manifestations and Detection of Tonic-Clonic Seizures With Acceleration Norm Entropy" *IEEE Transactions on Biomedical Engineering*, Vol. 60, No. 8, August 2013.
- [2] Imtiaz SA, et.al. IEEE J biomed Health inform. 2 "Performance power consumption trade -off in wearable epilepsy monitoring system" *Department of Electrical and Electronics engineering, Imperial college London*, 2015.
- [3] STAphane Bonnet, Pierre jallon, Michel antonakios "Motion -sensor based Alarm system for epilepsy monitoring" *IEEE* 2012.

- [4] T. Tzallas, M. G. Tsipouras, D. G. Tsalikakis, E. C. Karvounis, L. Astrakas, S. Konitsiotis and M. Tzaphlidou, "Automated Epileptic Seizure Detection Methods: A Review Study", InTech, 2012, ISBN: 978-953-51-0082-9.
- [5] G. Becq, P. Kahane, L. Minotti, S. Bonnet and R. Guillemaud, "Classification of Epileptic Motor Manifestations and Detection of Tonic–Clonic Seizures With Acceleration Norm Entropy," in *IEEE Transactions on Biomedical Engineering*, vol. 60, no. 8, pp. 2080-2088, Aug. 2013, doi: 10.1109/TBME.2013.2244597.
- [6] P. Guo, T. Jiang, Q. Zhang and K. Zhang, "Sleep Scheduling for Critical Event Monitoring in Wireless Sensor Networks," in *IEEE Transactions on Parallel and Distributed Systems*, vol. 23, no. 2, pp. 345-352, Feb. 2012, doi: 10.1109/TPDS.2011.165.
- [7] S. Otoum, M. Ahmed and H. T. Mouftah, "Sensor Medium Access Control (SMAC)-based epilepsy patients monitoring system," *2015 IEEE 28th Canadian Conference on Electrical and Computer Engineering (CCECE)*, Halifax, NS, Canada, 2015, pp. 1109-1114, doi: 10.1109/CCECE.2015.7129429.
- [8] A. Marquez, M. Dunn, J. Ciriaco and F. Farahmand, "iSeiz: A low-cost real-time seizure detection system utilizing cloud computing," *2017 IEEE Global Humanitarian Technology Conference (GHTC)*, San Jose, CA, USA, 2017, pp. 1-7, doi: 10.1109/GHTC.2017.8239249.

LiFi Technology

Sawant Anurag Ramkrishna
Student of Final Year BE E&TC
Sapkal College of Engineering Nashik India
anurag1sa2@gmail.com

Abstract—In wireless communication sector light fidelity is one of the future technologies. Lifi is a very high speed & is fully networked, which is a wireless technology similar to wifi. for better bandwidth, efficiency and speed a new technology a Lifi has evolved. Lifi used wireless technology utilizes light to transmit data and position between devices. In Lifi technology light is used as a medium. In lifi data is transmitted using light whose intensity varies faster than human eye to capture. Lifi used LED bulb with transceiver Date transmission is faster 100 times than Wi-Fi, LiFi technology proposed by German scientist Harald has LiFi provides higher bandwidth, efficiency, availability & security than WiFi. Lifi is a bidirectional wireless system that transmits data During this pandemic time a Day without internet is unimaginable. Now imagine a world where each LED light in and around hospitals can connect use to high speed wireless internet will. a simple flickering of light which is lift. This paper explains the basic need of Lifi over wi-fi. It describes modulations techniques used in Lifi technology for data transmissions. We can implement this system public internet access through street lamps auto-piloted cars. that communicate through their headlights. As the speed light is higher hence the data transmission Speed is so much faster that the existing system. In this paper describes the application of Lifi in different domains will help us to magnify the new research area in this technology.

Keywords—LiFi, Wifi

I. INTRODUCTION

Li-Fi uses the light spectrum transmitted by LED bulbs instead of gigahertz radio waves to transfer data. This machine communicates with the help of communication light spectrum and has no side effects as we know that light is an important part of our life and it is faster. The usable area in this spectrum has increased by 10,000 times, and usability has also increased with the introduction of LED lamps and lighting. Some examples of wireless applications include vehicle controls, Bluetooth, infrared and ultrasonic remote control devices, VHF radios, professional LMRs, SMRs, two-way radios (e.g. FRS), > GPS, cordless telephony, satellite TV . etc. Wi-Fi connection at home and within 10-100 meters Use our laptops, PCs, PDAs, etc. connect.

The article discusses visual communication with data speeds as fast as 500MBPS, which are now widely available. Major communication systems such as Wi-Fi, WiMAX and LI-Fi are examined and compared. Li-Fi will be the technology of the future for data transfer via light from laptops, PCs, smartphones and tablets[1]

It will send light into the room. It is safer because if you cannot see the light, you cannot enter the data. Therefore, it can be used to easily listen to radio communications in high security areas such as the military. Light-Fidelity technology was born in 2011. Harald Haas wrote the word LI FI and popularized LI-FI. Li-Fi is used to take advantage of high data transfer speeds. Li-Fi is a fast and cheap optical version of Wi-Fi. It is based on Visible Light Communication (VLC), which is used to transmit information using visible light. Wi-Fi uses the radio spectrum to transmit data, but it has some limitations due to the lack of radio frequency and the risk of interference.

Li-Fi uses light instead of gigahertz radio to transmit data. VLC is a data communications medium that uses light between 400 THz and 800 THz as the light carrier for data transmission and illumination.



Fig. 1 Professor Harald Haas at TEDx platform

High speed internet through LED, this experiment was performed by professor Harald Haas at TEDx platform as in Fig. 1. Where he had stream few video, pictures using LiFi. Other hand he just used study lamp to transfer the data[10].

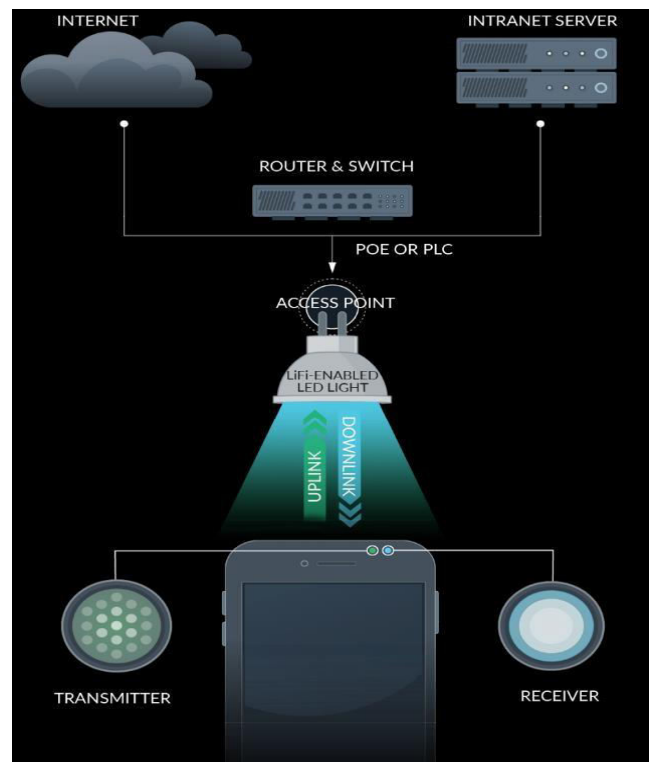

Fig.2 Working of LiFi for smart phone

Fig. 2 shows the working of LiFi transmitter & Receiver used for smart phone data transmission.

Li-Fi is a wireless communication system that transmits data through light. Li-Fi transfers data through LED bulbs that change intensity faster than the human eye can follow. Li-Fi is a framework that provides new capabilities for current and future services, applications and end users[5].

Time is fast called Wi-Fi replacement. Both concepts are shorthand examples of myths sometimes described in specialized form (e.g. Wi-Fi = wireless connectivity, Li-Fi = light fidelity). Haas's research project, originally called D light (short for Data Light), is now a newly formed VLC (Visible Light Communications) Ltd., which is incorporated as a technology company. The company is ready to create prototype Li-Fi applications under its name.

II. BLOCK DIAGRAM OF LiFi

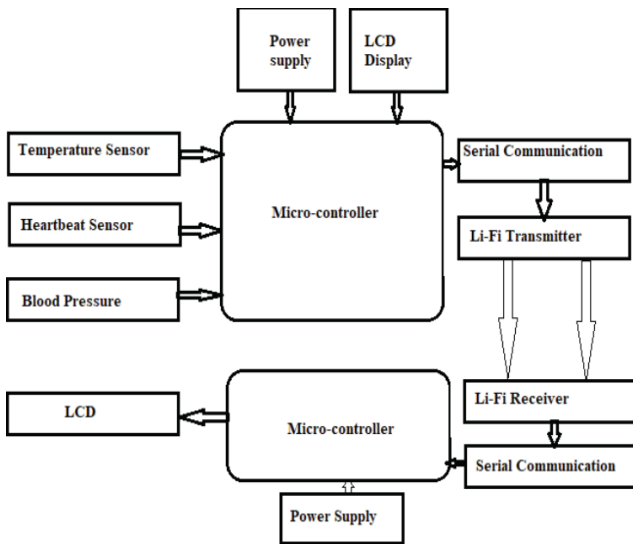

Fig. 3 Block diagram of LiFi

Block diagram of LiFi shown in Fig. 3. It requires two microcontrollers for transmitter and receiver. By using serial communication data transfer from source and receive at destination. Different types of sensors like temperature sensor, heartbeat sensor, blood pressure sensor etc. are used as per requirement and the application. The all transfer and receive data information is display on LCD display separately and power supply separately required in both side.

Li-Fi technology can be used for many purposes; the most important is data transmission through LEDs, so any light can be used as a platform for contact information. Mobile phone screens, televisions and lighting can be used as lighting. On the other hand, the receiving platform and photodetector can be replaced by the camera on the mobile phone for analysis and data collection purposes. Other applications include Li-fi for desktop computers, Li-fi for smart cards, Li-fi for schools, hospitals, Li-fi for cities, smart tips, museum, hotel, park, home and theater. LBS (location based services), access control and personal emergency, security environments such as shopping malls, airports and thermal power plants.

III. LITERATURE SURVEY

Researchers at the Heinrich Hertz Institute in Berlin, Germany, achieved data rates of over 500 megabits per second before using standard white LEDs[1].

The Li-Fi Alliance was founded in October 2011 by a group of companies and industry groups committed to promoting high-speed fiber optic wireless systems and overcoming the limitations of radio-based spectrum[3]. According to the Li-Fi Alliance, speeds of over 10 Gbps are expected and high-resolution videos can be downloaded in just 30 seconds[5,10].

Researchers at the University of Strathclyde in Scotland begin bringing high-speed, widespread Li-Fi technology to market Jiayuan Wang, Nianyu Zou, Dong Wang, IRIE Kentaro, Shan Zheng IHA (journal of China University of Posts and Telecommunications). This article measures the illumination of the received area between the LED and the photodiode receiver. It has been determined that light intensity decreases as communication distance increases.

IV. PRINCIPLE

Light Fidelity or Li-Fi could be Obvious Light Communications (VLC) framework running wireless communications voyaging at immoderate speed. The fundamental thought behind this communication scheme is transmission of Data through illumination. Large brightness LED is the Heart of Li-Fi innovation. The switching action of LEDs empowers a kind of information transmission utilizing binary codes mode in any case the human eye cannot see this alter and the LEDs show up to have a consistent escalated.

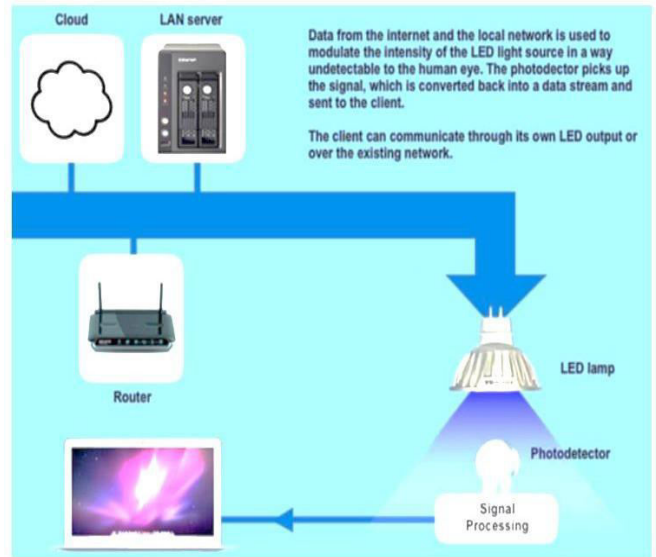

Fig. 4 LiFi working with LAN using LED lamp

As in the fig. 4 shown first using of cloud, router for the internet then its move to LED lamp when the lamp is on receiver at PC or phone receive the data so on the LiFi is working.

V. ADVANTAGES OF LI-FI

Li-Fi technology uses light to transmit data, regardless of which part of the visible or invisible spectrum is used. With sufficient downloading speed users can enjoy movies, music,

games, etc. in a short time by removing restrictions for Wi-Fi users.

Capacity: The bandwidth of light is 10,000 times wider than radio waves, giving Li-Fi better capacity.

Efficiency: Li-Fi works well because LED lights have low power consumption.

Availability: There are millions of light bulbs worldwide that need to be replaced with a suitable LED with a replaceable casing. Maybe in the future all street lighting can become free access points.

Security: Uses of Li-fi is safe and secure because it cannot penetrate human body like radio frequencies. Light waves can't penetrate through wall like electricity thus more secure.

Usage: Li-Fi can be used in underwater, airplane cabins, nuclear power plants etc. where Wi-Fi is not available or limited.

Safety: Unlike radio frequency, Li-Fi cannot penetrate the body.

VI. LIMITATION OF LI-FI

Like other technologies, Li-Fi technology also has some limitations and they are listed below:

- 1) The main disadvantage of Li-Fi is that the signal is blocked if any opaque material comes in between transmission.
- 2) It is valid only when there is line of sight between transmitter and receiver.
- 3) Reliability is another disadvantage since it interferes because of external sources such as constant light and sunlight.
- 4) The real challenge is how the receiver sends the information back to the transmitter.
- 5) Coverage is another issue, because Li-Fi uses a higher frequency, 400-800THz, which limits coverage to 120Mbps at 65 feet with a short range (practically over four feet above 500Mbps)[15].

VII. LI-FI APPLICATIONS

1. **Medical Applications:** Li-fi technology can be used in hospitals where wi-fi is unsafe due to radiations. Wi-Fi signals are limited in the operating room because it can block signals from monitoring equipment such as MRI equipment. But li-fi is good for robotic surgery[6].
2. **Road security and Vehicle Management:** Vehicles can communicate using li-fi through LED lights to prevent accidents and communication. Therefore, the incidence of accident events will decrease[7].
3. **Lighting:** All lighting, private or public, such as street lights, LIFI access points and can be used to provide lighting[8].
4. **Aviation:** Aircraft cabins are currently equipped with LED lights that can be used to provide high-speed internet access[9].

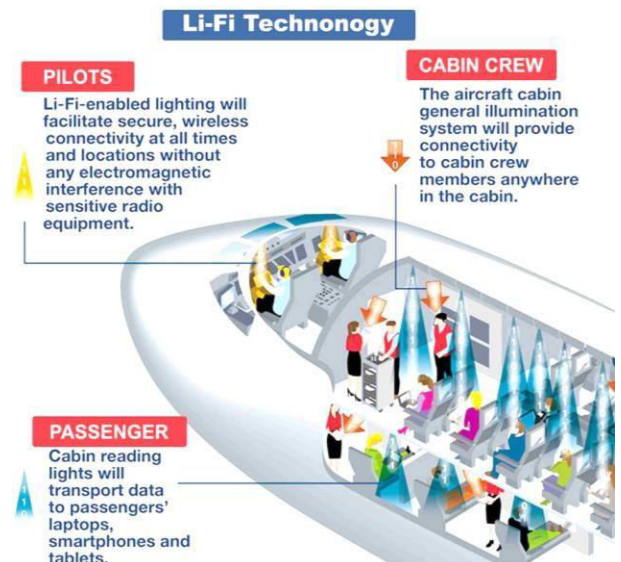

Fig. 5 Use of LiFi in aero plane

As in the above fig. 5 LiFi is used for Pilot without any electromagnetic interference, Cabin crew connectivity, Passenger can work on laptops, smartphone & tablets.

5. **Underwater communication:** LIFI can work underwater where Wi-Fi is completely inadequate. The use of LiFi in underwater ROVS (remotely operated vehicles) will allow them to communicate with each other using light instead of cables. Divers can also use flashlights to communicate. LIFI does not emit electromagnetic interference, so it does not interfere with medical equipment and is not affected by MRI scanners because its frequency is in the visible range as shown in the image below.
6. **Vehicles & Transportation:** Street lamps, signage and traffic signals are also using LiFi. This can be used for vehicle-to-vehicle and vehicle-to- roadside communications. This can be applied for road safety and traffic management as shown in fig. 6.

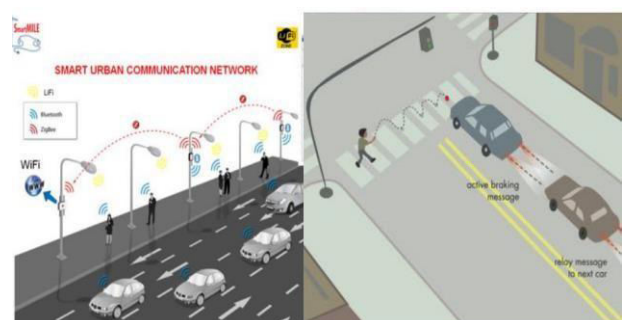

Fig. 6 LiFi in Vehicles & Transportation

VIII. LIFI OVER OTHER TECHNOLOGIES

- 1) **Mobile communications:** Compared to shorter distance WiFi, LiFi can provide more data (especially high downlinks) and security over long distance.
- 2) **Hospitals:** LiFi can be integrated into medical equipment and used in hospitals where Wi-Fi is

prohibited because it may cause electromagnetic interference with medical equipment and MRI scanners.

- 3) Aviation: LiFi can use LED lights already deployed on the aircraft. Using LEDs for communications can reduce heavy wiring and simplify living room layout.
- 4) Underwater communication: Radio waves are quickly absorbed by water, and sound waves can affect the ocean life, but LiFi uses optical signals, could be an alternative to this problem for short distance communication in water.
- 5) 5) Vehicle and traffic Control: LEDs can be used in headlights, tail-lights, road lights, traffic signals from vehicle to vehicle and vehicle to road communications. This prevents traffic congestion and makes traffic management more efficient.
- 6) Hazardous environment: LiFi uses signal signals for communication, so it can provide a safe alternative to electromagnetic interference from RF communication in mines and petrochemical plants like environment.
- 7) RF Spectrum Reduction: Due to excessive use of radio in communication, we will face reduced RF spectrum bandwidth. LiFi can be used as an alternative to radio in short-range communications
- 8) Avoidance of RF: Some people claim that radio frequencies used in mobile communications and Wi-Fi can cause brain damage. So LiFi solves this problem very well.

CONCLUSIONS

- 1) LiFi (light fidelity) is a new wireless communications technology that uses light to transmit data at high speed through electronic devices.
- 2) LiFi uses led lights to send data wirelessly instead of using radio frequencies, which are not used in traditional wi-fi. the technology works by using LEDs to convert information into fast pulses received by photodiode sensors in devices such as laptops, cell phones or smartwatches. the sensor then converts the signal into digital data for the device to use.
- 3) The process is similar to fiber optic technology but there is no need for physical cables. some of the advantages of lifi over traditional wi-fi include faster speeds, greater security, and the ability to work in areas that do not allow the use of radio frequencies, such as hospitals and airplane cabins. However, lifi also has some limitations, such as needing a direct line of sight between the transmitter and receiver and not being able to penetrate objects such as walls.
- 4) Overall, lifi is a new technology that has the potential to revolutionize the way we use the

internet; however, it is still in its infancy and needs further research to overcome its limitations.

IX. FUTURE SCOPE

There is no doubt that LiFi will change the way people connect to the internet in the online world. One possibility is that we will eventually have access to many technologies and be able to choose the most appropriate one. LiFi is the best scenario for this change. In India, many companies, including the Ladakh Institute of Education and Training (SECMOL), have started using Light Fidelity (LiFi) technology in schools[9].

REFERENCES

- [1] S. Rajagopal, R. Roberts, Lim S.-K., "IEEE 802.15.7 visible light communication: Modulation schemes and dimming support" IEEE Communication Magazine, vol. 50, no. 3, pp. 72–82, Mar. 2012.
- [2] M. D. Soltani, M. A. Arfaoui, I. Tavakkolnia, A. Ghayeb, M. Safari, C. M. Assi, M. O. Hasna and H. Haas, "Bidirectional Optical Spatial Modulation for Mobile Users: Toward a Practical Design for LiFi Systems," IEEE Journal on Selected Areas in Communications, vol. 37, no. 9, pp. 2069-2086, September 2019
- [3] R. Kizer, A. Mantica, N. McNeill, J. Tobin and S. Jones, "Li-fi-anoverview-part-1-purpose-and-function.," "IEEE Internet Policy Newsletter, June 2018. [Online]. Available: <https://internetinitiative.ieee.org/newsletter/june-2018/> . [Accessed 26 May 2020].
- [4] Sarkar, S. Agarwal, and A. Nath, "Li-Fi Technology: Data Transmission through Visible Light," International Journal, vol. 3, 2015.
- [5] Thanigavel, "Li-Fi Technology in Wireless Communication," in International Journal of Engineering Research and Technology, 2013.
- [6] Rigoutsos and T. Huynh. Chung-Kwei: a patterndiscovery-based system for the automatic identification of unsolicited e-mail messages (SPAM). Proceedings of the First Conference on E-mail and AntiSpam, 2004.
- [7] T. Koonen, J. Oh, K. Mekonnen, Z. Cao, E. Tangdionga "Indoor Optical Wireless Communication using Steered Pencil Beams" Journal of Lightwave Technology, Vol. 34, Issue 20, pp. 4802-4809, 2016.
- [8] A V. N. Jalajakumari, E. Xie, J. McKendry, E. Gu, M. D. Dawson, H. Haas, R.K. Henderson "High speed integrated

digital to light converter for short range visible light communication”, IEEE Photonics Technology Letters, 28.10.2016.

[9]
Sonam Wangchuk Discusses The World's First Mountain Top LiFi Laser 5G Internet From A Recent Mountain Expedition. Available:
<https://www.lifitn.com/blog/lifimountain>

[10]
Harald Haas. "Harald Haas: Wireless data from every light bulb". Ted.com. Archived from the Original, Accessed 24 June 2018 [Online Video] Available:https://www.ted.com/talks/harald_haas_wireless_data_from_every_light_bulb?language=en#t-750364.

[11]
A. Gomez, K. Shi, C. Quintana “Beyond 100-Gb/s iIndoor wide field-of-view optical wireless communications” IEEE Photonics Technology Letters, Volume: 27, Issue: 4, Feb.15, 2015

[12]
C.W. Oh, E. Tangdionga, A. M. J. Koonen, “42.8 Gbit/s indoor optical wireless communication with 2-dimensional optical beam-steering”, Optical Fiber Communications Conference and Exhibition (OFC), 2015.

[13]
S. Dimitrov, H. Haas, “Principles of LED Light Communications Towards Networked Li-Fi. Cambridge CB2 8BS, United Kingdom: Cambridge University Press, 2015

[14]
S. Dimitrov, H. Haas, “Optimum signal shaping in OFDM-based optical wireless communication systems” Proceedings of 64th IEEE Vehicular Technology Conference (VTC Fall), 2012.

[15]
O.D. Alao, J. V Joshua, A.S Franklyn, O. Komolafe “Light Fidelity (LiFi): An Emerging Technology for The Future” IOSR Journal of Mobile Computing & Application (IOSR-JMCA) e-ISSN: 2394-0050, P-ISSN: 2394-0042. Volume 3, Issue 3. (May. - Jun. 2016), PP 18-28.

An In-Depth Analysis of Spam Email: Review on Free Spam Email Data Corpus

Kalyani S. Ubale

*Research Scholar, Computer Engineering Department
K K Wagh Institute of Research and Technology
Nashik, India
E-mail: kalyaniubale110@gmail.com*

Dr. Kamini A. Shirsath

*Head of Department, Computer Engineering
Sandip Institute of Engineering and Management
Nashik, India
E-mail: kamini.nalavade@live.com*

Abstract—In today’s continuously evolving digital era, nature of email communication has paved the way for an alarming rise in spam emails, constituting a significant threat to cybersecurity. Also, numerous organizations are leveraging emails to sustain user interaction, marketing campaigns, and essential notifications had lead to calling for immediate attention for spam emails. Spam emails encompass a broad spectrum of unwanted and unsolicited messages, often characterized by deceptive tactics such as phishing, malware distribution, and social engineering. The evolution of spamming techniques has rendered traditional filtering methods inadequate, necessitating a deeper understanding of the evolving nature of spam. Free spam email datasets serve as invaluable resources for researchers, allowing them to analyze and model the intricate patterns and characteristics of spam emails. These datasets provide a realistic and dynamic representation of the ever-evolving landscape of spam, enabling the development and validation of sophisticated machine learning algorithms for spam detection and prevention. The datasets offer a diverse array of spam samples, ensuring a comprehensive understanding of the tactics employed by spammers across various contexts. In this paper we try to deliver into the intricate landscape of spam emails, exploring their characteristics, impact and the invaluable role of free spam email datasets in bolstering research and countermeasure development. We also presented an overall analysis of all the publicly available datasets by comparing them with respect to various characteristics like rate of spam emails, total number of instances, number of attributes considered, feature type, etc.

Keywords-Cybersecurity, Phishing email, spam, security attacks

I. INTRODUCTION

In the digital age, where communication is predominantly facilitated through electronic means, the prevalence of unsolicited and unwanted emails, commonly known as spam, has become a ubiquitous phenomenon. Spam emails inundate inboxes worldwide, cluttering personal and professional accounts with advertisements, scams, and malicious content. Understanding the impact of spam emails is crucial not only for individuals striving to maintain efficient communication channels but also for businesses seeking to safeguard their networks and reputation. The total number of emails sent every day is increasing each year. The total growth was observed from 269 to 333.2 billion, between the year 2017 and 2022, which means that over 64 billion more emails were sent every day compared to the last 5 years. The people say that, the most common medium they receive spam through is email, with almost half (49%) saying they receive spam via emails most often[1]. One spam email's carbon footprint is nearly 0.03g

of CO₂e. So in 2021, the number of spam emails sent could have released about 4.5 tonnes of CO₂e. There are different types of spam emails sent. The most common types of spam includes marketing, advertising, adult content, financial matters, scams and fraud. The 10 top most countries which send the most percentage of spam emails are as per the survey carried out on October 2021 are USA, China, Russia, Brazil, India, Germany, Czech Republic, Poland, Bulgaria and the UK [2]. A case study was carried out, in order to better understand the extent of the spam problem by AT&T and Lucent sub domains for a six month period beginning at the end of April 1997. The preliminary analysis of data collected at the end of six months has shown degradation in the performance of filters, due to spammers changing tactics [3]. It was also observed that, in the earlier years, spammers used to put messages in body of the emails which was known as the traditional way of spammers to send spam emails. But, since the last decade, email service has encounter the image spam as a new threat which has become a sophisticated kind of spam because it made the message more interesting for user and hard to classify it as spam for the filter. Image spam are rich in content and contain a variety of data, so image spam filters apply different methods on their filters to be able to detect image spam aiming to battle the image spammers. [14]. So, the increasing volume of unsolicited bulk e-mail has generated a need for reliable anti-spam filters. The filters of this type have so far been based mostly on keyword patterns that are constructed by hand and perform poorly. The thorough investigation of the performance of the Naïve Bayesian filter is done on the publicly available email corpus, contributing towards standard benchmarks[4]. The text categorization research has been benefited from the publicly available and manually categorized document collections known as the Reuters corpus (Lewis, 1992). The same has been used as benchmarks. One of the challenges observed in making standard e-mail corpus publicly available is that, creating similar resources for anti-spam filtering is not straightforward, as the user’s incoming e-mails cannot be made public without violating his or her privacy. One of the most common approach for such problem is mixing spam messages with messages extracted from spam-free public archives of the mailing lists. Towards that direction, we test Sahami et al.’s approach on a mixture of spam messages and messages sent via the Linguist list, a moderated (hence, spam-free) list about the profession and science of linguistics. The resulting corpus, dubbed Ling-Spam, is made publicly available for others to use as a benchmark[5,6]. Publicizing spam messages does not pose a problem, since spam messages are distributed blindly to very large numbers of recipients, and, hence, they are

effectively already publicly available. But the legitimate messages are in general harder to release online without violating the privacy of their recipients and senders. One way to bypass privacy problems is to experiment with legitimate messages collected from freely accessible newsgroups, or mailing lists with public archives[7]. To make a thorough evaluation we try to propose some of the popular publicly available spam email corpora. In this paper, we tried to highlight the basic properties of the various email spam datasets with its drawbacks and advantages so that they could be further efficiently used by researchers working on the spam data. We also proposed the different properties of datasets by considering the attributes related to the spam e-mails.

II. RELATED WORKS

The attempts to introduce the legal measures against spam mailing have had limited effect. A more effective solution is to develop tools to help recipients identify or remove automatically spam messages. Such tools are called anti-spam filters and vary in functionality from blacklists of frequent spammers to content-based filters. A new benchmark corpus was constructed, which is a mixture of spam messages and messages sent via a moderated (and, hence, spam-free) mailing list. The corpus is made publicly available for other researchers to use as a benchmark. Using this corpus, a thorough evaluation of the Naive Bayesian algorithm, used in (Sahami et al. 1998), was performed [4]. A thorough evaluation on a corpus that was made publicly available was conducted, contributing towards standard benchmarks. Also, the effect of attribute-set size, training-corpus size, lemmatization, and stop-lists on the filter's performance, were investigated, issues that had not been previously explored. After introducing appropriate cost-sensitive evaluation measures, the conclusion that additional safety nets are needed for the Naive Bayesian anti-spam filter to be viable in practice was made[5]. A scheme for combining classifiers, known as stacked generalization, in the context of anti-spam filtering, a novel cost-sensitive application of text categorization was evaluated. Using a public corpus known as Lingspam, they showed that stacking can improve the efficiency of automatically induced anti-spam filters, and that such filters can be used in the real life applications[6]. This paper presents an evaluation of memory-based learning in the context of anti-spam filtering. It also proposed a novel cost-sensitive application of text categorization that attempts to identify automatically unsolicited commercial messages that flood mailboxes. A thorough investigation of the effectiveness of a memory-based anti-spam filter is performed using a publicly available corpus, focusing on anti-spam filtering for mailing lists. The investigation includes different attribute and distance-weighting schemes, and studies on the effect of the neighborhood size, the size of the attribute set, and the size of the training corpus[7]. An investigation was done on four learning algorithms like Naive Bayes, Flexible Bayes, LogitBoost, Support Vector Machines, and four datasets, constructed from the mailboxes of different users. The worst-case computational complexity figures were discussed. A study of how classification accuracy is affected when using attributes that represent sequences of tokens, as opposed to single tokens is carried. The effect of the size of the attribute and training set, all within a cost-sensitive framework was also explored[8]. The evaluation of five supervised learning methods in the context of statistical

spam filtering is presented. The impact of different feature pruning methods and feature set sizes on each learner's performance using cost-sensitive measures is also studied. It was observed that the significance of feature selection varies greatly from classifier to classifier. In particular, support vector machine, AdaBoost, and maximum entropy model are top performers in the evaluation carried out, sharing similar characteristics: not sensitive to feature selection strategy, easily scalable to very high feature dimension, and good performances across different datasets. The evaluation was done on four spam corpora namely PU1, Ling, SA and ZH1[9]. A comparison was done of SVM, NB, boosted trees and stacking algorithms on the benchmark spam filtering corpora LingSpam and PU1. Conventional semi-supervised co-training requires the datasets to be described by two disjoint natural feature sets. Most datasets have a single set of features which limits the applicability of co-training. It was observed that if there is high data redundancy as in the domain of spam e-mail filtering, co-training with random feature split is as competitive as co-training with natural feature split[10]. A comparative study of seven different versions of Naive Bayes classifiers and the linear Support Vector Machine employed to automatically filter e-mail spam is presented.

TABLE I: PUBLICLY AVAILABLE EMAIL SPAM CORPUS

Dataset Name	Number of messages		Rate of spam	Year of creation	References
	Spam	Non-spam			
Spam archive	15090	0	100%	1998	Almeida and yamakami
Spambase	1813	2788	39%	1999	Sakkis et al
Lingspam	481	2412	17%	2000	Sakkis et al
PU1	481	618	44%	2000	Attar et al
Spamassassin	1897	4150	31%	2002	Apache spamassassin
PU2	142	579	20%	2003	Zhang et al
PU3	1826	2313	44%	2003	Zhang et al
PUA	571	571	50%	2003	Zhang et al
Zh1	1205	428	74%	2004	Zhang et al
Gen spam	31,196	9212	78%	2005	Cormack and lyman
Trec 2005	52,790	39,399	57%	2005	Androutsopoulos et al
Biggio	8549	0	100%	2005	Biggio et al
Phishing corpus	415	0	100%	2005	Abunimeh et al
Enron spam	20170	16545	55%	2006	Koprinska et al
Trec 2006	24,912	12,910	66%	2006	Androutsopoulos et al
Trec 2007	50,199	25,220	67%	2007	Debarr and Wechsler
Prince-ton spam image benchmark	1071	0	100%	2007	Wang et al
Dredze image spam	3297	2021	62%	2007	Dredze,gevaryahu and elias-bachrach
Hunter	928	810	53%	2008	Gao et al
Spamemail	1378	2949	32%	2010	Csmininggroup

Empirical experiments using six well known, large and public databases well known as Enron corpus were conducted. The results indicated that linear SVM, Boolean NB, MN Boolean NB, and Basic NB are the best choice for automatic filtering spam. SVM however, acquired the best average performance for all analyzed databases presenting an accuracy rate higher than 90% for all tested corpus. The comparison of the performance achieved by seven different Naive Bayes spam filters applied to classify messages from six well-known, real, public and large e-mail data sets, after a step of dimensionality reduction employed by eight popular term-selection techniques varying the number of selected terms was performed [11,12,18]. There is an increase recently in image-based spam. All the proposed techniques have the same target, trying to avoid the image spam entering our inboxes. Image spammers avoid the filter by using different tricks and each of them needs to be analyzed to determine what facility the filters need to have for overcoming the tricks and not allowing spammers to full our inbox. Different tricks give rise to different techniques. This work surveys image spam phenomena from all sides, containing definitions, image spam tricks, anti image spam techniques, data set, etc. The proposed method extracts efficient global image features to train an advanced binary classifier to distinguish the spam images, which achieves promising preliminary results on the sample dataset considered [13, 19,21]. Experimental results, using TREC and CEAS data sets collected from spam detection competition are challenging spam benchmark sets, show that the Random Boost method significantly improves the performance of the spam filter compared to the Logit Boost algorithm, and yields similar classification accuracy compared to the Random Forest method but uses only one fourth the runtime complexity of the Random Forest[14]. From the experiments carried out on the SpamAssassin corpus the underlying ideas behind feature selection methods are identified and applied for improving the feature selection process of SpamHunting, a novel anti-spam filtering software able to accurately classify suspicious e-mails[15]. There are many applications available for detection of phishing data. However, unlike predicting spam, there are only few studies that compare machine learning techniques in predicting phishing data. A data set of 2889 phishing and legitimate emails is used in the comparative study. In addition, 43 features are used to train and test the classifiers. The results claim a detection rate of 95% of phishing emails with a low false positive rate[20].

III. BENCHMARK CORPUS FOR SPAM FILTERING

This section describes the various publicly available email spam corpus. There is a variety of data observed in the spam email datasets which contains textual data, image data and phishing emails. A tremendous increase has been observed recently in the spam emails related to all the mentioned types of spam data. Publicizing spam messages does not pose a problem, since spam messages are distributed blindly to very large numbers of recipients, and hence, they are effectively already publicly available. Legitimate messages, however, in general cannot be released without violating the privacy of their recipients and senders. One way to bypass privacy problems is to experiment with legitimate messages collected from freely accessible newsgroups, or mailing lists with public archives. It is necessary to understand the properties and attributes present in all the dataset for an extensive research in the

field of spam emails. So, here we will focus on some of the popularly available spam email corpus.

TABLE II: CHARACTERISTICS OF PUBLICLY AVAILABLE EMAIL SPAM CORPUS

Dataset Name	Dataset characteristic	Associated tasks	Feature type	Features
Spam archive	Multivariate	Classification	Integer	Varies
Spam base	Multivariate	Classification	Integer, Real	57
Ling spam	Multivariate	Classification	Char, Integer	50
PU1	Multivariate	Classification	Integer	Varies
Spam assassin	Multivariate	Classification	Integer	100
PU2	Multivariate	Classification	Integer	Varies
PU3	Multivariate	Classification	Integer	Varies
PUA	Multivariate	Classification	Integer	Varies
Zh1	Multivariate	Classification	Integer, Char	3000
Trec 2005	Multivariate	Prediction	Integer, Char, Real	Varies
Phishing corpus	Multivariate	Classification	Integer, Real	43
Enron spam	Multivariate	Classification	Integer, Real	375
Trec 2006	Multivariate	Prediction	Integer, Char, Real	Varies
Trec 2007	Multivariate	Prediction	Integer, Char, Real	135
Ceas 2008	Multivariate	Classification	Integer, Char, Real	50
Princeton spam image bench mark	Multivariate	Classification	Integer, Char, Real	23
Dredze image spam dataset	Multivariate	Classification	Integer, Char, Real	24
Hunter	Multivariate	Classification	Integer, Real	64
Spam email	Multivariate	Classification	Integer, Real	57

A. Spamarchive:

The <https://untroubled.org/spam/> directory contains all the spam that was have received since early 1998. This archive is provided for the purposes of researching behavior of spammers and development of new spam management techniques. Most of the messages in this archive contain forged headers in one form or another. The fact that a message claims to have come from one particular address or another does not mean it actually originated at that address. The only way to determine where a message originated is to do a careful study of the Received: headers, and even then much of the information cannot be trusted. The number of messages in the archive for 2007 is lower than for 2006 or 2008. During 2006, this address started receiving increasingly large amounts of spam, making it hard to process the mail effectively. By 2008, the amount of spam to the other addresses had increased back to the same levels. All the recent spam data has been updated till the year 2024 by creating separate folders in the spam archive folder.

B. Spambase:

The spam email database is available at the UCI Machine Learning Repository http://www.ics.uci.edu/~mlearn/ML_Repository.html. The database was created by Mark Hopkins, Erik Reeber, George Forman, Jaap Suermondt Hewlett-Packard Labs in July 1999. The collection of spam e-mails was taken from postmaster and individuals who had filed spam. The collection of non-spam e-mails came from filed work and personal e-mails, and hence the word 'george' and the area code '650' are indicators of non-spam in the database. These are useful when constructing a personalized spam filter. The total number of instances present in the database is 4601, among which 1813 are spam emails i.e.39.4% of the total instances. The attributes considered for classification are 58, in which 57 are continuous attributes and one is a nominal class label, which denotes whether the email is spam or not.

C. Lingspam:

The benchmark corpus lingspam is a mixture of spam messages and messages received via the Linguist list, a moderated mailing list about the profession and science of linguistics. The corpus contains 10 directories. It consists of 2893 messages among which 2412 are Linguist messages, obtained by randomly downloading digests from the list's archives, breaking the digests into their messages, and removing text added by the list's server. 481 spam messages, received by the first author. Attachments, HTML tags, and duplicate spam messages received on the same day is not included. Spam messages are 16.6% of the corpus, a figure close to the spam rates of the authors, Sahami et al.'s fourth experiment, and rates reported elsewhere (Cranor & LaMacchia, 1998). Although the Linguist messages are more topic-specific than most users' incoming email, they are less standardized than one might expect (e.g. they contain job postings, software availability announcements, even flame-like responses). Hence, useful preliminary conclusions about anti-spam filtering can be reached with Ling-Spam, until better public corpora become available.

D. PU:

The PU corpus is available in four versions:with or without stemming and with or without stop word removal.. The versions are named as PU1, PU2, PU3, and PUA. All these datasets are available onthe following (<http://www.aueb.gr/users/ion/data/PU123ACorpora.tar.gz>, 2019).The legitimate messages in PU1 are the English legitimate messages that the first author had received and saved over a period of 36 months, excluding self-addressed messages. The PU1 corpus consists of 1099 messages, 481 of which are marked as spam and 618 are labeled as legitimate, with a spam rate of 43.77%. The messages in PU1 corpus have header fields and HTML tags removed, leaving only subject line and mail body text. To address privacy, each token was mapped to a unique integer. PU2 was constructed in the same way, starting from the legitimate and spam messages that a colleague of the authors had received over a period of 22 months. The vast majority of his legitimate messages were RC. PU3 and PUA contain the legitimate messages that the second author and another colleague, respectively, had saved up to the time of our experiments; unlike PU1 and PU2, non-English (e.g., Greek) legitimate messages were not removed.

E. SpamAssassin:

The SpamAssassin corpus is a larger collection made available by spamassassin.org. All messages come in raw email format. This makes it possible to evaluate the contribution of header fields in classifying spams. The SpamAssassin public mail corpus is similar to Ling-Spam, in that its legitimate messages are publicly available. It contains 1897 spam and 4150 legitimate messages with a spam rate of 31.37%, the latter collected from public fora or donated by users with the understanding that they may be made public. The corpus is less topic-specific than Ling-Spam, but its legitimate messages are again not indicative of the legitimate messages that would arrive at the mailbox of a single user, this time for the opposite reason. Many of the legitimate messages that a user receives contain terminology reflecting his/her profession, interests, etc. that is rare in spam messages, and part of the success of personal learning-based filters is due to the fact that they learn to identify this user-specific terminology. In a concatenation of legitimate messages from different users this user-specific terminology becomes harder to identify. Hence, the performance of a learning-based filter on the SpamAssassin corpus may be an under-estimate of the performance that a personal filter can achieve.

F. ZH1:

ZH1 is a Chinese Spam Corpus. While good spam filtering results have been reported on several English corpora, it is still unclear whether the same technique is effective in other language settings. To explore this point, we compiled a publicly available Chinese spam corpus named ZH1. The ZH1 corpus is made up of 1205 spam messages and 428 legitimate messages collected by the first author, with a spam rate of 73.79%. The messages in ZH1 corpus are all simplified Chinese text with GB2312/GBK encoding. Unlike English where there are explicit boundaries between words, Chinese text is written continuously without word delimitation. To apply the word-based spam-filtering techniques to Chinese, the Chinese text was segmented into words with a Chinese word segmenter developed by the Natural Language Processing Lab, Northeastern University. All Chinese texts in header fields, message body, sender, and recipient's names are tokenized into words before further processing.

G. TREC:

The TREC 2007 corpus consists of 75,419 messages collected at the University of Waterloo from April 4 to July 6, 2007 (3 months). It is made up of 25,220 legitimate and 50,199 spam email. TREC corpus contains three versions of datasets Trec 2005,2006, and 2007. It is considered as one of the most complicated dataset among spam email.

H. Phishing corpus:

Similar to the "spam email database" donated by Forman and created by Hopkins et al., a phishing data set by processing a set of 1171 raw phishing emails collected between November 15, 2005 and 7 August, 2006 was constructed. This set of phishing emails covers many of the newer trends in phishing. For the legitimate portion of the data set, 1718 messages collected from the mailboxes were considered. Hence in total the dataset contains 2889 emails, 59.5% of them are legitimate. The dataset consists of 43 continuous features (variables) and one binary response variable, which indicates that email is phishing=1 or

legitimate=0. The features represent the frequency of the most frequent terms that appear in phishing and legitimate emails.

I. Enron:

The six public, large and well-known datasets present in Enron corpora, organized into 6 folders. Each time five folders are used for training and the remaining one is used for testing. All datasets are composed by real legitimate messages extracted from the mailboxes of former employees of the Enron Corporation and selected spam messages from different sources. Enron-spam corpus contains preprocessed and raw forms of Enron-Spam datasets, amounting to 33716 total messages. The “preprocessed” directory contains the messages in preprocessed format. Attachments, HTML tags, and duplicate spam messages received on the same day are not included. The “raw” directory contains the messages in their original form. Spam messages in non-Latin encodings, ham messages sent by the owners of the mailboxes to themselves (sender in “To:”, “Cc:”, or “Bcc” field), and a handful of virus-infected messages have been removed, but no other modification has been made. The corpus is arranged into 6 directories that contains a combination of non-spam and spam messages

CONCLUSION

The accessibility of publicly available spam email corpora for research has significantly advanced the field of cybersecurity and spam detection. Throughout this review paper, we have explored the myriad benefits and implications of utilizing these corpora, emphasizing their pivotal role in shaping the development of effective spam filtering techniques and enhancing our understanding of spamming behavior. One of the key advantages of publicly available spam email corpora is their role in fostering innovation and collaboration within the research community.

Moreover, the open nature of these corpora encourages transparency and reproducibility in research, allowing findings to be independently verified and validated by other scholars. Additionally, publicly available spam email corpora serve as invaluable resources for studying the evolving tactics and strategies employed by spammers. By analyzing large-scale datasets spanning diverse sources and time periods, researchers can gain insights into the underlying patterns and trends driving spamming activity, helping to inform the development of more robust and adaptive spam detection systems.

Furthermore, the inclusion of metadata such as sender information and email headers enables researchers to investigate the social and technical aspects of spamming behavior, shedding light on the motivations and mechanisms behind spam campaigns. Moreover, the availability of spam email corpora has facilitated interdisciplinary collaborations between researchers from various fields, including computer science, linguistics, and psychology. By integrating insights from diverse disciplines, researchers can develop more comprehensive and nuanced models of spamming behavior, leading to more effective countermeasures and mitigation strategies.

FUTURE WORK AND CHALLENGES

Furthermore, interdisciplinary collaborations enable researchers to explore novel approaches to spam detection, such as leveraging linguistic and psychological cues to identify deceptive or manipulative content. Despite their numerous benefits, publicly available spam email corpora also pose certain challenges and limitations. For instance, concerns regarding privacy and ethical considerations may arise due to the use of real email data in research. To address these concerns, many spam email corpora are anonymized or sanitized to remove personally identifiable information and sensitive content.

TABLE III: COMPARING VARIOUS EMAIL DATASETS WITH THEIR FEATURES

Dataset	Source	Size	Label (Spam/Ham)	Features
Spamemail	Various sources	Varies	Binary	- Subject line - Body text - Sender email address - Recipient email address
Spam base	UCI machine learning repository	0.4 MB	Binary	- Word frequency features (e.g., 'make', 'money', 'free')
Spam assassin	Spam Assassin public corpus	3.3 GB	Binary	- Email text (both body and headers) - Metadata (e.g., date, sender, subject)
Lingspam	Lingspam dataset	20 MB	Binary	- Bag of words features - Metadata (e.g., subject line, sender, date)
PU corpus	Research dataset	0.4 GB	Binary	- Bag of words features - Metadata (e.g., subject line, sender, date)
Phishing corpus	Various sources	Varies	Binary	- HTML content features - Metadata (e.g., URL, domain)
Zh1	Research dataset	Varies	Binary	- Bag of words features - Metadata (e.g., subject line, sender, date)
Enron spam	Enron Email Dataset	12.8 MB	Binary	- Email text (both body and headers) - Metadata (e.g., subject line, sender, date)
Trec	TREC public spam corpora	Varies	Binary	- Email text (both body and headers) - Metadata (e.g., date, sender, subject)

However, the effectiveness of these measures may vary, and researchers must take precautions to ensure that their use of spam email corpora complies with ethical guidelines and regulations. Additionally, the dynamic nature of spamming activity presents challenges in maintaining the relevance and currency of spam email corpora. As spammers continually adapt their tactics and techniques to evade detection, existing corpora may quickly become outdated, necessitating regular updates and maintenance. Furthermore, the emergence of new communication channels and platforms, such as social media and messaging apps, poses new challenges for spam detection and requires the development of novel datasets and methodologies to address these evolving threats.

REFERENCES

- [1] Cai, Robert, "Spam statistics(2024): New data on junk email, AI scams and phishing", online blog, 19 Oct 2023.
- [2] Jyothiika Moorthy, "23 email spam statistics to know in 2024", online blog, 8 Aug 2023.
- [3] L. F. Cranor, B. A. Lamacchia, "Spam!", *Communication of the ACM*, vol. 41, issue 8, Aug 1998.
- [4] I. Androutsopoulos, J. Koutsias, K.V. Chandrinou, G. Paliouras, C.D. Spyropoulos, Learning to filter spam E-mail : a comparison of a naïve bayesian and a memory based approach, in: *Proceedings of 4th European Conference on Principles and Practice of Knowledge Discovery in Databases*, Lyon, France, September 2000, 2000, pp. 1–12.
- [5] I. Androutsopoulos, J. Koutsias, K.V. Chandrinou, G. Paliouras, C.D. Spyropoulos, "An evaluation of naïve bayesian anti-spam filtering", in: *Proceedings of 11th European Conference on Machine Learning (ECML 2000)*, Barcelona, 2000, pp. 9–17.
- [6] G. Sakkis, I. Androutsopoulos, G. Paliouras, V. Karkaletsis, "A memory based approach to anti-spam filtering for mailing lists", in: *Empirical Methods in Natural Language Processing*, 2001, pp. 44–50.
- [7] G. Sakkis, I. Androutsopoulos, G. Paliouras, V. Karkaletsis, "Stacking classifiers for anti-spam filtering of E-mail", in: *Kluwer academic publishers*, 2003, pp. 49–73.
- [8] I. Androutsopoulos, G. Paliouras, E. Michelakis, "Learning to Filter Unsolicited Commercial E-Mail", *National Centre for Scientific Research Demokritos*, Athens, Greece, Oct 2006.
- [9] L. Zhang, J. Zhu, T. Yao, "An evaluation of statistical spam filtering techniques spam filtering as text categorization", *ACM Trans. Asian Lang. Inf. Process* 3 (4) (2004) 243–269.
- [10] I. Koprinska, J. Poon, J. Clark, J. Chan, "Learning to classify e-mail", *Inf. Sci.* 177 (10) (2007) 2167–2187.
- [11] G.V. Cormack, T.R. Lynam, "On-line supervised spam filter evaluation", *ACM Trans. Inf. Syst.* 25 (3) (2007).
- [12] T.A. Almeida, A. Yamakami, "Content-based spam filtering," in: *The 2010 International Joint Conference on Neural Networks (IJCNN)*, Barcelona, 2010, pp. 1–7.
- [13] T.A. Almeida, A. Yamakami, "Spam filtering: how the dimensionality reduction affects the accuracy of Naïve Bayes classifiers," in: *J Internet Serv Appl*, 2011, pp. 183–200.
- [14] A. Attar, R.M. Rad, R.E. Atani, "A survey of image spamming and filtering techniques", *Artif. Intell. Rev.* 40 (1) (2011) 71–105.
- [15] D. DeBarr, H. Wechsler, "Spam detection using random forest", in: *Pattern recognition letters*, Elsevier, 2012, pp-1237-1244.
- [16] B. Issac, "Spam detection approaches with case study implementation on spam corpora", in: *Researchgate*, 2010.
- [17] J.R. Mendez, F. Diaz, E.L. Iglesias, J.M. Corchado, "A comparative performance study of feature selection methods for the anti-spam filtering domain", in: *Advances in Data Mining. Applications in Medicine, Web Mining, Marketing, Image and Signal Mining*, Springer Berlin Heidelberg, 2006, pp. 106–120.
- [18] D. Gaurav, S. M. Tiwari, A. Goyal, N. Gandhi, A. Abraham, "Machine intelligence-based algorithms for spam filtering on document labeling", *Soft computing*, Springer-Verlag GmbH Germany, Nov2019.
- [19] Y. Gao, M. Yang, X. Zhao, B. Pardo, Y. Wu, T. Pappas, A. Choudhary, "Image spam hunter", in: *Proc. Of the 33th IEEE International Conference on Acoustics, Speech, and Signal Processing*, Las Vegas, NV, USA, 2008.
- [20] S. Abu-nimeh, D. Nappa, X. Wang, S. Nair, "A comparison of machine learning techniques for phishing detection", in: *eCrime 07: Proceedings of the Antiphishing Working Groups 2nd Annual eCrime Researchers Summit*, New York, USA, 2007, pp. 60–69.
- [21] Z. Wang, W. Josephson, Q. Lv, M. Charikar, K. Li, "Filtering image spam with nearduplicate detection", in: *Proc of the Fourth Conf on Email and Anti-spam*, 2007.
- [22] B. Biggio, I. Corona, G. Fumera, G. Giacinto, F. Roli, "Bagging classifiers for fighting poisoning attacks in adversarial classification tasks", in: *Multiple Classifier Systems*, Springer Berlin Heidelberg, 2011, pp. 350–359.
- [23] M. Dredze, R. Gevayahu, A. Elias-Bachrach, "Learning fast classifiers for image spam", in: *Proc of the Fourth Conf on Email and Anti-spam*, 2007.
- [24] I. Androutsopoulos. (2000). *Ling-Spam*. Aueb.gr. Accessed: Oct. 11, 2019. [Online]. Available: http://www.aueb.gr/users/ion/data/lingspam_public.tar.gz
- [25] I. Androutsopoulos, V. Metsis, and G. Paliouras. (2006). *The Enron-Spam Datasets*. Accessed: Oct. 11, 2019. [Online]. Available: <http://www2.aueb.gr/users/ion/data/enron-spam/>
- [26] I. Androutsopoulos, G. Paliouras, and E. Michelakis. (2003). *PU Corpus*. Accessed: Oct. 1, 2019. [Online]. Available: <http://www.aueb.gr/users/ion/data/PU123ACorpora.tar.gz>

Platform for Trading Energy Between Peers for Residential Power Systems

1st Nachiket Nawatakke
Department of Electronics and
Computer Science

SIES Graduate School of Technology
Nerul, India
nachiketn101@siesgst.ac.in

2nd Yash Aslekar Department
of Electronics and Computer
Science

SIES Graduate School of Technology
Nerul, India
yashaslekar@gmail.com

3rd Aditya Jadhav

Department of Electronics
and Computer Science
SIES Graduate School of
Technology Nerul, India
adityakishorjadhav@gmail.com

4th Purnima Patil

Department of Electronics and
Computer Science
SIES Graduate School of Technology
Nerul, India
Purnimap@siesgst.ac.in

Abstract— The coming of peer-to-peer (P2P) push trading has heralded a decentralized image for push imagination central, transcending the demand for intermediary. This transformative access empowers consumer and manufacturer to directly transact push, enabling individual to monetize spare electricity within a networked ecosystem that minimizes trust on ceremonious usefulness provider. P2P push trading unfolds on a spectrum encompassing both localized and grand-scale implementation, ranging from community-based network to cross-commodity central. Distinctive property of P2P push trading program resides in their real-time monitoring capacity for push propagation and use, advanced pricing algorithm that inform optimum trading strategy, and nonrational exploiter interface approachable through online program.

These program also foster community participation by providing societal feature for user to running their push use, economy, and environmental shock. Through model work and real-world original project, P2P push trading program have demonstrated the possible to promote push autonomy, grim electricity measure, and encourage renewable push borrowing at case-by-case and grassroots level. Beyond possession, these program cultivate a sensation of collaborationism among player, crucial for construction resilient and sustainable push ecosystem.

Keywords: Peer-to-peer energy trading; residential power systems; energy marketplace; decentralized energy trading; smart grid technology; energy sharing platform; microgrid trading; neighbor-to-neighbor energy exchange.

I. INTRODUCTION

As the ball-shaped push view undergoes a transformative transformation towards environmental stewardship and push liberty, the control of renewable sources notably solar

photovoltaics—has profoundly shaped the landscape. Amidst this image break, a noteworthy creation has emerged: the decentralized might central of peer-to-peer (P2P) trading. This image challenge traditional usefulness control, empowering prosumers—including a home equipped with rooftop solar panels—to directly engage in push dealing. P2P program purchases up-to-date technology such a blockchain, impertinent contract, and IoT sensor, ensuring foil, secrecy, and in operation efficiency. By eliminating intermediary, P2P trading empowers electricity producer and consumer alike. This thoroughgoing psychoanalysis DELF into the origin, execution, and likely shock of a P2P push trading program specifically tailored for residential solar facility. Exploring technical progress, marketplace dynamic, regulative landscape, and orbicular example work, the study postulate that P2P trading keep the transformative voltage to augment the value proposal of solar push within the reinforced surroundings.

The account address underlying question surrounding P2P trading program, including challenge ilk integration solar push into existing might grid, motivation of client involvement, and navigating expert and regulative hurdle. In end, the account contributes to the talks on sustainable push transition by offer insight, analysis, and actionable recommendation for policymakers, manufacture stakeholder, consumer, and community, aiming to unlock the benefit of peer-to-peer push trading for a more sustainable and bouncy manufacture.

II. EFFICIENT CONSUMPTION

Harnessing effective push use lie at the core of successful peer-to-peer push trading program for residential solar system. Demand answer example empower consumer to modulate their use in answer to marketplace dynamic and grid restraint. Smart place technology optimizes push use by orchestrating energy-intensive activity during period of copious solar propagation. Peer-to-peer initiative within push community foster collaborationism and imagination communion, enhancing sustainability. Incentive mechanism, such an active pricing, feed-in duty, and advantage plan,

catalyse push preservation and the borrowing of renewable push source. Empowered by these programs, user assume command over their push use, reduction of cost and mitigating environmental shock, frankincense bolstering community resiliency and semipermanent sustainability. In effect, peer-to-peer push trading program establish a decentralized, effective, and just push ecosystem, propelled by technical progress, marketplace incentive, and the corporate action of scented consumer.

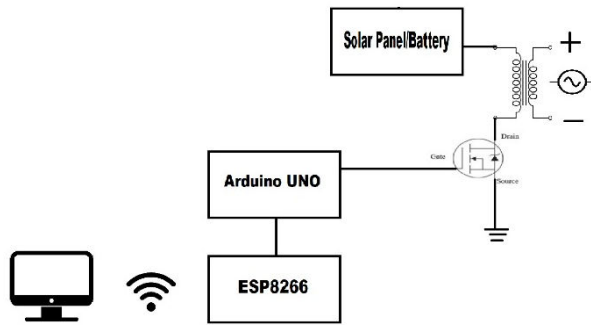

Fig. 1. Block diagram

III. APPROACHES TOWARDS ENERGY EFFICIENCY

Leveraging technical synergism and community participation, peer-to-peer push program empower consumer to assume an alive part in formation the push landscape. Demand-side direction empowers them to dynamically adjust use normal in answer to gridiron term and marketplace variation, optimizing push use. Smart household mechanization harness solar accessibility to optimize convenience programming, maximizing renewable push concentration. Peer-to-peer optimization fosters collaborationism within community, reconciliation provision and need piece promoting resiliency. Incentive mechanism, including dynamical pricing and advantage program, incentivize push preservation and renewable acceptance, raising a cultivation of environmental stewardship. This comprehensive access integrates demand-side direction, mechanization, peer-to-peer optimization, and incentive, enhancing push efficiency, resiliency, and fairness in peer-to-peer push trading program. Through technical progress and collaborative effort, these programs pave the means for a sustainable, decentralized, and just push ecosystem.

IV. ENERGY SAVING BASED ON BEHAVIORAL CHANGE

In P2P push trading program, optimizing organization efficiency need the culture of energy-saving behavior. This necessitates influencing position and use through real-time feedback on push use, societal comparative strategy, and individualized recommendation. By raising a communal ethos and corporate duty, the program encourage player to central strategy, celebrate achievement, and engage in energy-saving

competition. Tailored treatment, uninterrupted training, and outreach opening further reinforce energy-conserving conduct in the tenacious condition. Integrating insight from behavioral skill and societal psychology empowers consumer to brand informed decision, reduce push wastage, and maximize renewable push use. Through these multifaceted coming, P2P push trading program contribute to the building of a sustainable and live push hereafter.

V. ENERGY HUBS AND MICROGRIDS

In the decentralized push landscape, push hub and microgrids emerge a pioneering creation, raising peer-to-peer (P2P) push trading model for residential solar system. Energy hub, a fundamental control center in local push network, orchestrate the collection, dispersion, and optimization of push resource, connecting homeowner, business, and utility. Integrating renewable push propagation, memory system, and demand-side direction technology, they maximize the use of locally generated push, diminishing dependency on centralized dispersion. Microgrids, self-reliant from centralized grid, establish a localized push ecosystem within the outlined edge. Comprising interrelated solar PV installation, heterogeneous push source, and sassy gridiron technology, microgrids empower the user to optimize push use, enhance resiliency, and reduce electricity cost. Through P2P trading, microgrid member engage in unmediated push dealing, communion excess content and collaboratively managing resource, raising push independence and minimizing trust on extraneous source. Together, push hub and microgrids bolster push resiliency by mitigating grid failure and disaster, piece empowering consumer to actively participate in their push provision and contribute to local push product.

VI. INTELLIGENT ENERGY MANAGEMENT SYSTEM (IEMS)

Intelligent Energy Management Systems (IEMS) constitute the basis of peer-to-peer (P2P) push trading program designed for residential solar system. Harnessing advanced digital architecture, advanced information analytics, and self-reliant performance, this system optimize push product, use, and trading in real-time, raising heightened efficiency, dependability, and sustainability. IEMS seamlessly integrates and orchestrates a comprehensive room of push plus, encompassing solar photovoltaic genesis, bombardment store, electrical vehicle, and demand-responsive device. Leveraging real-time information from meteoric forecast, push use profile, and marketplace news, IEMS strategically allocates uncommitted push resource to meet need, maximizing self-consumption and minimizing international push trust. Additionally, IEMS empowers homeowner a dynamic player in P2P push trading by providing them with comprehensive insight, analytic tool, and user-centric port useable through wandering application. The consolidation of blockchain engineering and fresh declaration functionality ensures secure, transparent, and automated push dealing among prosumers within the local push ecosystem, enhancing confidence and efficiency in P2P push trading process. In conclusion, IEMS represents a cornerstone in unlocking the full potential of P2P energy trading platforms for residential solar systems.

VII. SENSORS AND MEASURING INFORMATION

Advanced detector and measurement system service a backbone of optimized peer-to-peer (P2P) push trading program for residential solar system. This system provides an uninterrupted current of operating argument, push use information, and grid term, empowering homeowner with the decisive data they want to brand intelligent decision and automate push direction strategy. Through the punctilious monitoring of solar irradiance, board temperature, and electricity product, this system facilitates the fleet recognition of anomaly and maximize push take. Furthermore, they go priceless insight into use form, enabling homeowner to implement targeted push preservation measure and optimize their push use. This real-time data central fosters efficient push direction practice, resulting in rock-bottom push expense and weakened environmental shock. Beyond enhancing functional efficiency, sensor also turn a polar part in optimizing push trading within P2P network. By gather information on grid term and marketplace dynamic, they enable homeowner to brand informed decision regarding push trading. Integrating with demand-response plan and grid appurtenant help, sensor empower homeowner to actively participate in grid-stabilizing action, contributing to overall grid resiliency. In core, sensor and measurement system are essential for maximizing grid consolidation, optimizing push use, and bolstering resiliency within P2P push trading program for residential solar system.

VIII. ACTUATORS – DIRECT CONTROL

The unmediated control mechanics service an essential part of peer-to-peer (P2P) push trading, particularly in the setting of residential solar system. It empowers homeowner with punctilious command over energy-consuming device, guided by both predefined argument and extraneous cue, thereby optimizing push efficiency and support unseamed grid integrating. By modulating twist setting in consonance with version in push product, use, and marketplace dynamic, homeowner behind mitigate dissipation and amplify self-consumption of solar push without the demand for manual treatment. The mechanics also affords active response to outside signal, such a peak need to surgery oscillatory electricity cost, contributing to gridiron constancy and balance. Through integrating with P2P trading program, homeowner behind collaborate, facilitating real-time push communion and bolstering community resiliency. In center, the lineal control mechanics orchestrates a decentralized, effective, and conjunctive push direction image within a P2P solar system.

IX. ACTUATOR - INDIRECT CONTROL

Actuators, an essential part in P2P push trading for solar system, empower collateral control by automating energy-consuming device. Leveraging preset schedule, user preference, and real-time information, they optimize push use, minimize dissipation, and augment householder ease without manual treatment. This actuator, responding to extraneous sign such a marketplace dynamic surgery grid emergency, enable homeowner to engage in grid-balancing opening and reap the

benefit of need answer incentive. By maximizing self-consumption of solar push and facilitating P2P push communion, they contribute to gridiron constancy and resiliency. Integrated with P2P trading program, they automate push dealing and imagination allotment, raising collaborationism among homeowner for the effective use of renewable push source.

X. WORKING OF THE PROCESSING ENGINE

The processing engine, a computational backbone of the P2P push trading ecosystem geared toward the solar system, orchestrates real-time interaction among manufacturer, consumer, and the gridiron. It harnesses information from diverse source, coalescing and discerning it through advanced algorithm to render actionable insight. By synergizing data on solar propagation, bombardment store, need, and consumer leaning, it optimizes push use for maximized self-consumption, minimized expense, and sustained grid balance. Moreover, it facilitates P2P push trading, harmonizing provision with need and executing dealing with blockchain-based protection protocol. Thus, the processing loco motor empowers homeowner to actively build a decentralized, sustainable push landscape by leverage renewable resource and bolstering grid constancy and resiliency through fighting grid direction.

XI. USER INTERFACE

Encapsulating the ether of user interaction with peer-to-peer (P2P) push trading program, the exploiter port (UI) emerges a polar conduit for homeowner. It presents a comprehensive tableau of real-time update, insightful analytics, and interactional functionality, empowering informed decision-making. A holistic sailing ecosystem orchestrates fundamental faculty, encompassing push monitoring, trading market, and community conflict. Central to this is a crystalline fascia, to offer a bird's-eye thought of genesis, use, store, and trading action. Granular insight is manifested through graph, chart, and tabular agency, enabling the user to discern push use form and envision optimization view. Interactive component and customizable setting augment the exploiter experience, piece trading capacity facilitate push excess monetization and community collaborationism. A data-rich product graph visualizes push metric, including solar propagation, grid central, and bombardment use. The UI's unseamed consolidation empowers homeowner to actively engage in P2P push trading, raising sustainable push practice within their community.

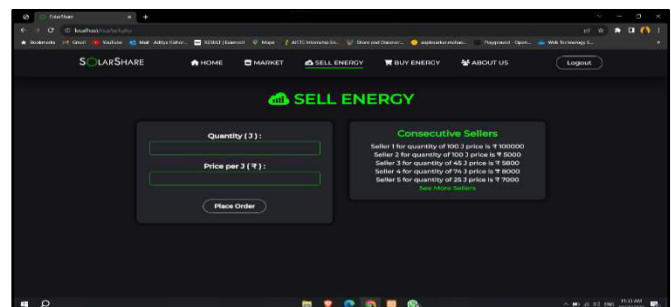

Fig. 2. Trading platform UI

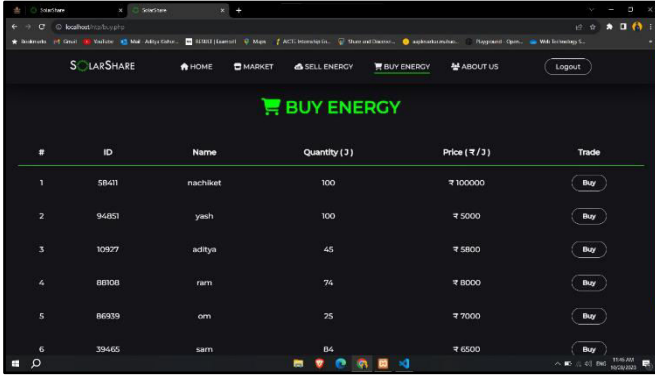

Fig. 3. Trading platform UI - II

XII. RESEARCH AREAS

Delineating the technical creation of peer-to-peer energy trading need a nuanced testing of blockchain and distributed ledger technology, evaluating their scalability and efficacy. Advanced gridiron technology, such as an AMI and grid mechanization, optimize energy trading process, mitigating web restraint and facilitating real-time monitoring. Economic example delves into the elaboration of pricing and bonus mechanism, in quest to ensure just value dispersion and marketplace efficiency. Regulatory model is meticulously analyzed to can marketplace dynamic and likely barrier, raising constancy and fight. Comprehending consumer conduct and societal interaction provides insight for crafting strategy that raising community cooperation and confidence. Environmental shock assessment illuminates the transformative benefit, including emission reducing and increased renewable push borrowing, piece addressing net over-crowding and stakeholder responsibility to enhance sustainability.

XIII. FUTURE SCOPE

As the technical tapes entwines blockchain and IoT, the hereafter of peer-to-peer push trading unfurls, fraught with possible. The nascent bud of case-by-case place coalesce into verdant community and microgrids, raising a decentralized ecosystem that predecessor push democratization and sustainability. Requisite, regulative framework mustiness metamorphose to raising this development, guaranteeing grid constancy and investor trust. Social lead wafting eco-consciousness propel consumer employment in renewable project and collaborative push effort. In effect, P2P trading portends a more just and lively push landscape, orchestrated by the philharmonic of creation, supportive policy, and community involvement.

Author	Title	Findings
Sarat Kumar Sahoo	Development of utility assisting controllers for solarized irrigation system	In farming, about seventeen % of internal push use is used, mostly for irrigation. To cutting nursery emission, there's an energy for electrical heart facility, which testament likely addition electricity need.
Arjun Baliyan	Intelligent Energy Management System for a Smart Home Integrated with Renewable Energy Resources	The report suggests integration of solar, battery, and device to optimize push, reduce grid dependency, and rise gross. It emphasizes Home Energy Management (HEM) with renewables for effective residential burden command, proposing farther work on time-of-use pricing strategy.
Stavros Mischos	Intelligent energy management systems: a review	The report categorizes Intelligent Energy Management Systems (ITEMS) by propulsion (verbatim vs. indirect command). It advises lineal command for commercial-grade building and indirect command for educational setting, a piece advocating for low-priced collateral command choice for residential purpose.
Hamza Görgülü	Peer-to-peer energy trading among smart homes considering responsive demand and interactive visual interface for monitoring	The report introduces an algorithm for push trading among 4 consumer examples, enabling optimization, visualization, and price judgment in assorted scenario.

XV. RESULTS

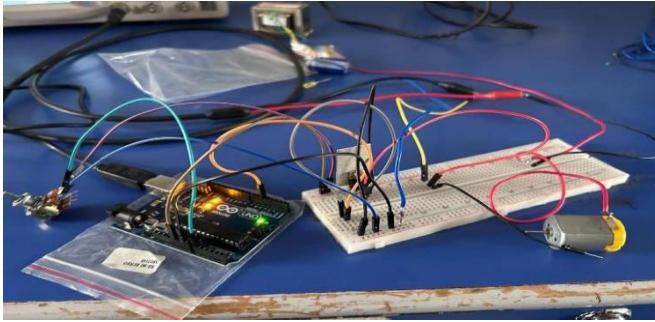

Fig. 4. Circuit connection



Fig. 5. PWM signal

ESP8266 Control Panel

Status: On

Manual Input

Enter Brightness (0-100):

Fig. 6. ESP8266 Control Panel

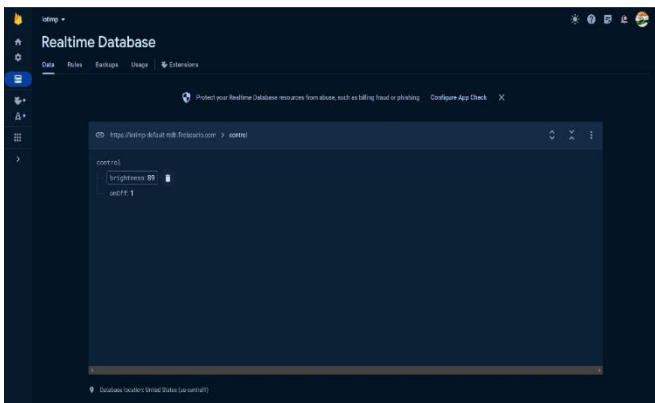

Fig. 7. Realtime database

XVI. CONCLUSION

The project successfully established a peer-to-peer energy sharing system using pulse width modulation (PWM) signals to regulate power transfer, allowing precise control over energy transactions by adjusting wave duration. The implementation of

Node MCU facilitated remote control and monitoring over the internet, enhancing accessibility. Having accomplished nearly half of the project objectives, significant progress was demonstrated, accompanied by invaluable learning experiences in electronics, website development, model making, and Node MCU utilization. Looking forward, the project will focus on integrating IoT functionalities and refining power sharing mechanisms, recognizing the complexity involved and emphasizing careful planning. This strategic approach ensures a well-structured project timeline aligned with the project's scope and complexity, reflecting a responsible and pragmatic project management strategy.

XVII. REFERENCES

- [1] Baliyan, A., Mwakitalima, I.J., Jamil, M. and Rizwan, M., 2022. Intelligent Energy Management System for a Smart Home Integrated with Renewable Energy Resources. *International Journal of Photoenergy*, 2022.
- [2] Görgülü, H., Topçuoğlu, Y., Yıldız, A., Gökçek, T., Ateş, Y. and Erdinç, O., 2022. Peer-to-peer energy trading among smart homes considering responsive demand and interactive visual interface for monitoring. *Sustainable Energy, Grids and Networks*, 29, p.100584.
- [3] Mischos, S., Dalagdi, E. and Vrakas, D., 2023. Intelligent energy management systems: a review. *Artificial Intelligence Review*, pp.1-40.
- [4] Sarkar, S.J., Kundu, P.K., Sahoo, S.K., Panigrahi, T.K., Patro, P.S. and Rajak, A., 2023. Development of utility assisting controllers for solarized irrigation system. *Renewable Energy Focus*, 45, pp.53-67.
- [5] Das, A., Peu, S.D., Akanda, M.A.M. and Islam, A.R.M.T., 2023. Peer-to-Peer energy trading pricing mechanisms: towards a comprehensive analysis of energy and network service pricing (NSP) mechanisms to get sustainable enviro-economical energy sector. *Energies*, 16(5), p.2198

BMS and Motor Controls for Range Extended Electric Vehicle (REEV)

S.S.Gite¹

Assistant Professor,
Department of Electronics and Telecommunication
Engineering,
Amrutvahini College of Engineering, Maharashtra,
India

G. Mahesh², D. Mahesh³

U.G Students,
Department of Electronics and Telecommunication
Engineering,
Amrutvahini College of Engineering, Maharashtra,
India

Abstract: - Hybrid electric vehicles (HEVs) combine an internal combustion engine with an electric motor to improve fuel efficiency and reduce emissions. A Battery Management System (BMS) and Motor Controls are pivotal components in Hybrid Electric Vehicles (HEVs) that play a crucial role in optimizing performance, efficiency, and safety. It monitors individual cell voltages, temperatures, and state of charge, thermal management, and fault detection. On the other hand, Motor Controls in HEVs regulate the power distribution between the internal combustion engine and electric motor(s), maintaining a balance. These controls manage torque, speed, and regenerative braking, seamlessly transitioning between electric and gasoline power sources

Keywords- Hybrid electric vehicles, Battery Management system, Motor Controls.

Introduction

Range-extended electric vehicles (REEVs) have emerged as a promising solution to address the challenges associated with range anxiety and infrastructure limitations in conventional electric vehicles (EVs). These automobiles incorporate an internal combustion engine (ICE) generator in conjunction with an electric drivetrain and a battery pack, thereby expanding their driving range beyond the capabilities of solely battery-powered electric vehicles. At the core of the smooth operation of Range-Extended Electric Vehicles (REEVs) are the Battery Management Systems (BMS) and Motor Controls, which play essential roles in overseeing energy distribution, guaranteeing operational effectiveness, and maximizing overall performance. The BMS within a REEV is tasked with monitoring the state of the battery pack, encompassing parameters such as voltage, current, and temperature. It orchestrates the charging and discharging processes to maintain the battery within its designated safe operating thresholds, thereby maximizing its lifespan and ensuring utmost reliability. Additionally, the BMS interfaces with the vehicle's motor control system, furnishing real-time data and facilitating optimization of power delivery based on prevailing driving conditions, thereby enhancing both efficiency and performance. Furthermore, it serves as a diagnostic tool, providing insights into voltage and current flow while promptly identifying and reporting any system faults. In a Range-Extended Electric Vehicle (REEV), motor controls oversee the distribution of power among the battery, electric motor, and generator, guaranteeing seamless operation and optimizing energy utilization. Utilizing advanced algorithms, these systems regulate torque delivery, speed, and regenerative braking, thereby improving vehicle dynamics and driving satisfaction. Through efficient synchronization of the Battery Management System (BMS) and motor controls, REEVs can attain peak performance, increased range, and diminished

environmental footprint, positioning them as an attractive option for sustainable mobility solutions.

LITERATURE REVIEW

1. This paper addresses the critical role of Battery Management Systems (BMS) in electric vehicles, which oversee the charging and discharging processes of batteries to optimize both performance and longevity.
2. The paper outlines a comprehensive approach encompassing the design, performance assessment, and validation of a PMDC motor tailored for electric vehicle applications. This is achieved through a combination of modelling, simulation, and experimental validation methodologies.
3. Within the document, there is a detailed exploration of the development and control strategies pertinent to hybrid electric vehicles (HEVs). The emphasis is placed on the imperative of efficient and environmentally conscious propulsion within the automotive sector. Furthermore, it delves into the integration of diverse electrical systems and control methodologies to attain peak performance levels.
4. A thorough discussion is presented regarding the indispensable role of Battery Management Systems (BMS) in electric vehicles. Particular attention is given to the necessity for high-power batteries and compatible BMS technologies to ensure safe and dependable operations. Additionally, the document undertakes a comparative analysis between lithium-ion (Li-ion) and Nickel-Metal Hydride (NiMH) batteries, focusing on aspects such as aging and the impact of temperature, utilizing metrics such as state of charge (SOC) and open circuit voltage (OCV).

NEED OF PROJECT

1. Battery Management Systems (BMS) play a pivotal role in Hybrid Electric Vehicles (HEVs) by overseeing and regulating the performance of the vehicle's battery pack.
2. BMS ensures the optimal health, safety, and efficiency of the battery by overseeing charging and discharging operations, maintaining balance among individual cell voltages, and safeguarding against overcharging or over-discharging events.
3. The combined efforts of the Battery Management System (BMS) and PMDC motor control significantly contribute to the enhancement of efficiency, reliability, and lifespan of Hybrid Electric Vehicles (HEVs), thereby establishing them as indispensable components of contemporary HEV technology.

PROPOSED METHODOLOGY

The suggested approach for managing batteries and motor controls in range-extended electric vehicles (REEVs) entails the integration of cutting-edge Battery Management Systems (BMS) to oversee and enhance battery performance. This involves the deployment of advanced algorithms for real-time estimation of battery state, effective thermal management, and equitable distribution of charge among battery cells. Furthermore, sophisticated motor control strategies are implemented to optimize efficiency and increase driving range, such as field-oriented control (FOC) for motor drive and systems for regenerative braking. The overarching objective of this methodology is to elevate vehicle performance, extend its driving range, and ensure the durability of the battery pack.

BLOCK DIAGRAM

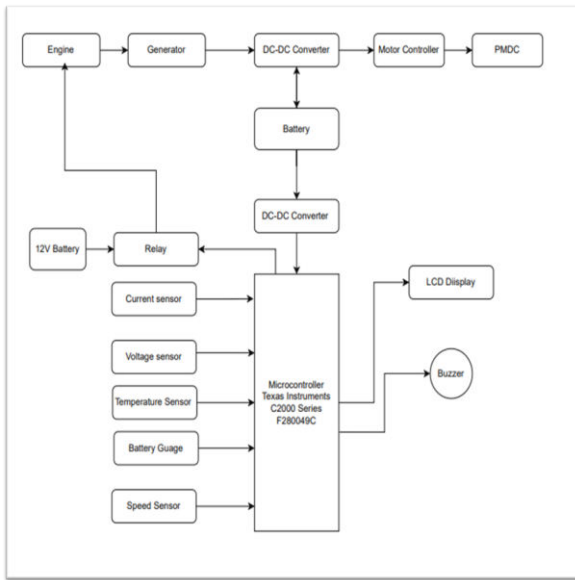

Fig. 1: Block Diagram of The System

1. IC Engine: 4 stroke single cylinder engine of 10 CC.
2. Generator: The generator is used to convert mechanical energy to electrical energy for transmission and distribution over power lines to domestic, commercial, and industrial customers.
3. Controller: Here in this project two controllers are used, the motor controller and main controller to control low voltage designs.
4. PMDC Motor: The motor is used to rotate the shaft and further to the wheels
5. Lithium Ion Battery: Battery is used to power the motor because battery needs electrical power supply.
6. Sensors and output devices: The sensors are used to sense the data accordingly and give to the output devices like LCD Display.

EQUATIONS FOR MICROMOTOR AND BATTERY

1. Motor Equations:

$$P_{total} = (m \cdot g \cdot u) \cdot v + (0.5 \cdot c \cdot a \cdot d \cdot v^2) \cdot v + (m \cdot g \cdot \sin Q) \cdot v$$

where P total= Total Power

m: mass of vehicle= 340kg

g: acceleration due to gravity= 9.81m/s²

u: rolling resistance= 0.01

c: drag coefficient= 0.30

a: frontal area= 1.1475m²

d: density of air= 1.2kg/m³

v: velocity=74kmph= 20.55m/s

Q: inclined angle= 3

$$\text{Torque} = 1000 \cdot 60 \cdot P / 2\pi \cdot n$$

n: RPM

2. Battery Equations

$$\text{Total force} = (m \cdot g \cdot u) + (0.5 \cdot c \cdot a \cdot d \cdot v^2) + (m \cdot g \cdot \sin Q)$$

$$\text{Battery capacity} = \text{Force(N)} \cdot \text{range(km)} / 3600$$

$$\text{Force} = \text{Total force} - \text{gradient force}$$

$$\text{Energy consumption} = P_{total}(\text{kw}) / \text{vehicle speed(miles/hr)}$$

$$\text{Electric range} = \text{Battery capacity} / \text{Energy consumption}$$

ALGORITHM

algorithm of Hybrid Electric Vehicles

Step 1: System Initialization:

- Commence the Hybrid Electric Vehicle (HEV) startup procedure.
- Establish the initial battery charge level.
- Deactivate the generator to an OFF state.

Step 2: Battery Percentage Monitoring:

- Continuously assess the battery charge level.

Step 3: Core Operational Cycle:

- While the vehicle remains in operation, sustain ongoing monitoring of the battery charge level and generator status.

Step 4: Battery Charge Assessment:

- In the event the battery charge level falls below 40%:
- Activate the generator.
- Switch the generator status to ON.
- Initiate the battery recharging process.

Step 5: Generator Power Generation:

- When the generator is activated, it initiates electricity production.
- Transform the generated electricity into the requisite voltage and current for battery replenishment.

Step 6: Battery Replenishment:

- Direct the produced electricity to the battery for recharge.
- Monitor the progress of battery charging.

Step 7: Completion of Battery Recharge:

- Upon attainment of a satisfactory battery charge level (e.g., 80%):
- Deactivate the generator.
- Update the generator status to OFF.
- Cease the battery recharging operation.

Step 8: Motor Power Assessment:

- If the generator status is OFF, the motor necessitates power for propulsion.
- Ascertain the power requirements of the motor.

Step 9: Power Source Allocation:

- If the generator status is ON, utilize the generator as the power source for the motor.
- If the generator status is OFF, utilize the battery as the power source for the motor.

Step 10: Motor Propulsion:

- Direct the chosen power source to the electric motor for propulsion.
- Adjust the power output to regulate the vehicle's speed.

Step 11: Continuation of Core Operational Cycle:

- Iteratively execute steps 2 through 10 for the duration of vehicle operation.

Step 12: Shutdown Procedure:

- Upon vehicle shutdown, discontinue all power generation and propulsion systems

FLOW CHART

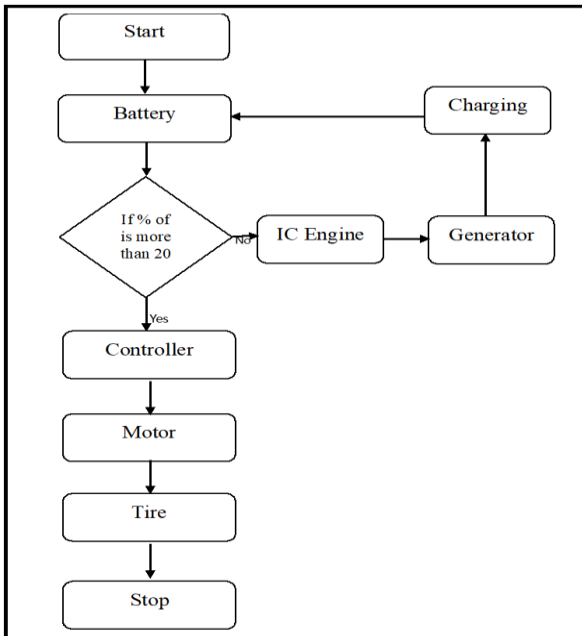

Fig. 2: Flow Chart of the system

ADVANTAGES

1. Hybrid Electric Vehicles (HEVs) integrate an Internal Combustion (IC) engine with an electric motor, enabling enhanced operational efficiency, particularly in urban driving scenarios. HEVs exhibit reduced emissions in comparison to conventional gasoline or diesel vehicles.
2. HEVs demonstrate diminished emissions when juxtaposed with traditional gasoline vehicles.
3. HEVs employ regenerative braking mechanisms to capture and retain energy typically dissipated as heat during braking maneuvers.
4. Electric motors operate with lower noise levels in contrast to internal combustion engines, thereby contributing to a reduction in urban noise pollution.

5. Numerous governmental bodies provide incentives, such as tax credits or rebates, to foster the adoption of HEVs.

DISADVANTAGES

1. Hybrid Electric Vehicles (HEVs) typically incur higher initial costs relative to traditional gasoline or diesel counterparts, attributable to the incorporation of dual powertrain components.
2. The dual powertrain configuration in HEVs may introduce added complexity, necessitating supplementary maintenance and potentially elevating repair expenses.
3. In contrast to pure Electric Vehicles (EVs), HEVs face limitations in their electric-only capabilities due to the absence of a widespread charging infrastructure.
4. Over time, the high-voltage battery within HEVs may experience degradation, resulting in diminished overall efficiency and vehicle performance.

APPLICATIONS

1. Hybrid Electric Vehicles (HEVs) are frequently integrated into passenger cars and Sport Utility Vehicles (SUVs), offering a harmonious blend of fuel efficiency and practicality ideal for daily commuting requirements.
2. Many urban centers adopt HEVs for buses and other modes of public transit to mitigate emissions and curtail fuel consumption.
3. HEVs find application in delivery and logistics vehicles, effectively curbing fuel expenses and emissions during frequent stop-and-go driving scenarios.
4. HEVs are favored within taxi services due to their enhanced fuel efficiency and reduced operational expenditures.
5. Government entities and municipal authorities leverage HEVs across diverse functions, encompassing utilization in police cruisers, maintenance vehicles, and administrative fleets alike.

SPECIFICATIONS

1. Battery

Battery pack configuration	6S 6p
Battery nominal voltage	51.2 V
Battery capacity	90 Ah
Battery operating voltage	44.8V to 58V
Life cycle	2000
Casing type	Metal
Battery operating temperature	0°C - 65°C
Continuous discharge current	200A (can be change as per bms Rating)
Pulse discharge current	300A

Table 1: Battery pack technical specifications.

2. Motor

Parameter	Description
Max RPM	3500
Peak Power	11.5 KW
Weight	20Kg
Rated Torque	22 Nm
Ambient Temperature	32°C
Dimension (L*B*H)	(220*120*220) (in mm)

Table 2: PMDC Motor technical specifications

3. Motor Controller

Motor Control Type	PMDC
Input Current Rating	152 A
Output Current Rating	145 A
Voltage Rating	48 V
Efficiency	85%
Cooling	Air Cooling
Derating	0.86
Coupling Mechanism	Belt Drive

Table 3: Motor Controller technical specifications

FUTURE SCOPE

1. Advance battery technologies, such as solid-state batteries, to enhance energy density, decrease weight, and extend the range of hybrid vehicles.
2. Develop a comprehensive infrastructure of wireless charging stations to streamline recharging processes and incentivize the uptake of hybrid vehicles.
3. Integrate autonomous driving functionalities into hybrid vehicles to enhance operational efficiency and safety, thereby augmenting their appeal to consumers.
4. Deploy Vehicle-To-Grid (V2G) technology within hybrid vehicles to enable the storage of surplus energy and facilitate its redistribution into the grid during periods of peak demand.

RESULT

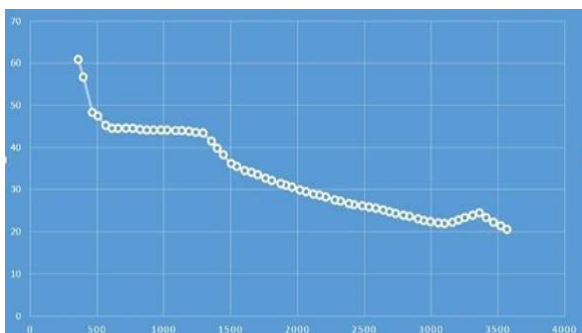

Fig 4: RPM VS Torque

The above graph shows us that, as the RPM increases Torque Decreases. It shows that Torque and RPM are inversely proportional to each other. there is more reduction in the torque in the initial stage and as the RPM increases torque gradually decreases

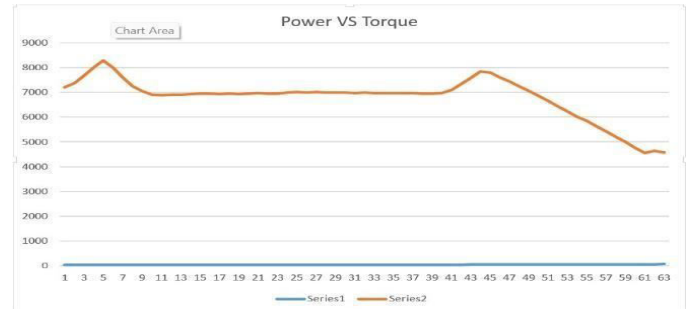

Fig 5: Power Vs Torque

The above graph will give us the different values of torque at different power ratings. This estimates us that what is the power required at various torque.

CONCLUSION

Hybrid Electric Vehicles have emerged as a promising solution in the endeavor to diminish fuel consumption and emissions. Through our research, we have effectively demonstrated the efficacy of integrating electric and internal combustion engines to enhance fuel efficiency and mitigate environmental impact. Our findings underscore the viability of hybrid vehicles as a sustainable and eco-conscious mode of transportation for the foreseeable future. Continued exploration and advancement in this domain are poised to yield even more efficient and environmentally sustainable hybrid electric vehicles. This endeavor underscores the significance of embracing hybrid technology to tackle environmental challenges while ensuring practicality and convenience for consumers. Ultimately, hybrid electric vehicles represent a progressive stride towards a cleaner and more sustainable future in transportation.

REFERENCE

- [1] Hariprasad, "Battery Management System in Electric Vehicles", International Journal of Engineering Research & Technology (IJERT), Vol. 9 Issue 05, May-2020.
- [2] Assistant Prof. Sanjeeth P, Vishwanath Chalawadi, "Design and Analysis of PMDC Motor for Electric Vehicle", International Journal of Scientific Research in Engineering and Management (IJSREM), Volume: 06 Issue: 07, July – 2022.
- [3] G.Livint, Vasile Horga, "Control of Hybrid Electric Vehicles", Research gate,2 May 2022.
- [4] V Karkuzhal, "Analysis of battery management system issues in electric vehicles", IOP Conference Series: Materials Science and Engineering, 2020.
- [5] A. Ahmed, D. D. Bhutia, "Propulsion System Design and Sizing of an Electric Vehicle", International Journal of Electronics and Electrical Engineering, Volume 3, No. 1, Feb. 2015.
- [6] Sanjay Kumar, "Hybrid Electric Vehicle", International Journal of Engineering Research & Technology (IJERT), Volume 7, Issue 11, 2019.

Scaling Google: With Advancements and Innovations In Scalability Features.

Author- Mrs. Shweta V. Thorat
Sandip University, Nashik
Research Scholar- shweta.bhalerao93@gmail.com

ABSTRACT-

In today's fast-paced world, staying at the forefront of technological advancements is just a click away. Pursuing excellence and the desire for fresh experiences drive our constant quest for the best, enriching the universe with innovation and cutting-edge technology. In the ever-evolving landscape of the modern world, the constant quest for the latest technology has become synonymous with one-click accessibility. In the past few decades, there has been a rapid growth in technologies, accompanied by a substantial increase in their widespread usage. The relationship between technology and the user is deeply interconnected, marked by a symbiotic, co-dependent, and mutually influential dynamic. Users and technology are intricately linked, shaping and influencing each other in a continuous and evolving partnership. Science and technology systems, including mobile phones, computers, and smart TVs, are not only created by humans but also reflect the fundamental aspects of the population's needs and lifestyle. These technological advancements have become integral to the fabric of society, influencing how individuals communicate, work, and live. The landscape has undergone significant transformations, particularly in the aftermath of the COVID-19 pandemic. This global crisis has catalyzed substantial changes, prompting a heightened awareness among professionals and the private sector. Indeed, in this dynamic environment, individuals from all walks of life professionals, students, senior citizens, and beyond are engaged in a continuous cycle of learning, unlearning, earning, thinking, teaching, communicating, and relearning.

KEYWORDS- Search engine, SE optimization process, Web Pages, Crawling

Technique, Indexing, Page Rank Algorithm, and Database.

INTRODUCTION-

During the pandemic phase, everyone is searching for content also they are entertaining themselves with various kinds of devices. At that point, all are not literate enough to access the browser but can search on Google also familiar with the virtual world because there is already in built-in library for the user or suggested content. The search results of a user query or request are often returned as listed forms and hits. The hits may consist of web pages, images, and other types of files. A variety of data mining techniques are used in all aspects of search engines, ranging from crawling, indexing, and searching. Google Search is a fully automated search engine that uses software web crawlers that explore the web regularly to find pages to add to an index. The most popular technique is the Google search algorithm technique, which is easily one of the most influential technologies ever created. It refers to the process Google uses to rank content. These are taking the account hundreds of factors, including keyword mentions, usability, and backlinks. With an estimated 5.6 billion Google searches per day, it's safe to say Google has a heavy influence pact on the world and multiple types of business. Google's algorithm is extremely complex and it exactly works with the help of different types of techniques. Finally displays the various related links of content from the index. Simply see the concept of the index in the search engine here; an index is a process by which search engines organize information before a search to able the super-fast response to queries or requested content. The major practical challenge associated with a Focused Crawler is to appropriately classify the various kinds of web pages based on the given topic due to the

unstructured data in web pages, manual feature extraction is very difficult while dealing with web pages.. Here the main objective of this research work is to design an improved focused Crawling approach using web page classification. In Google searching, there are several techniques as well as algorithms that run behind the user's front side.

RESEARCH ON THE POPUP OPTION

If the user searches for any information through the URL or keywords, there are sequentially displayed lots of websites. Assume a user wants all content on one Web page, but can't get all relevant content on a current webpage. There should be a sort or filter for all sites users in search of. Suppose, a new user or student discovers any topic's information, the user is fully confused here, because which is the better one? The user can't find appropriate information Now try to resolve the problem with the help of a popup option that should be directly generated beside the "All" tool or category. Primary, all popup options, display the following contents 1. Fundamental, 2. Diagram, 3. Risk and Challenges, 4. Benefits and Drawbacks etc. The popup option is not only helpful for a student, but all kinds of users can access it and will directly jump on particular content. The side of the database would store data like Music, Recipe, Department, clothes, Furniture, Appliances, Toys, etc. These days, as per the user needs, with the help of advanced technology huge data can be stored and can be managed in a cloud system. The whole thing will be the same on the front page like the interface, tools, language options, and more options. A few changes will best perform for fast accessing data and availability of data in a few seconds then the user will be satisfied with one click.



Fig. Research On Popup Option.

METHODOLOGY

1. The Search Engine - The search engine is a software system designed to retrieve information from the internet. It allows users to enter queries (keywords or phrases) and returns a list of relevant web pages or other content. Popular search engines include Google, Bing, and Yahoo. It allows users to enter queries (keywords or phrases) and returns a list of relevant web pages or other content. Popular search engines include Google, Bing, and Yahoo. The SE is an online tool that is designed to search for a website on the network based on user search queries. SE is a coordinated set of programs that discover and identify items in a designed database. The search engine allows users to search the content through the network using the help of keywords that look for the results in its databases, sort them, and order the listing form of these results using a unique search algorithm. Users can search by a particular website or URL or keywords (contents name). The search engine is the primary method for browsing with the keywords and many kinds to build for finding information. Each search engine often uses advanced search options that focus on the user to search better and help to find what users are looking for. It contains different kinds of categories or segregation to be easy to make use of front user. Everybody can search out to particular concept through using the tools of search engines.

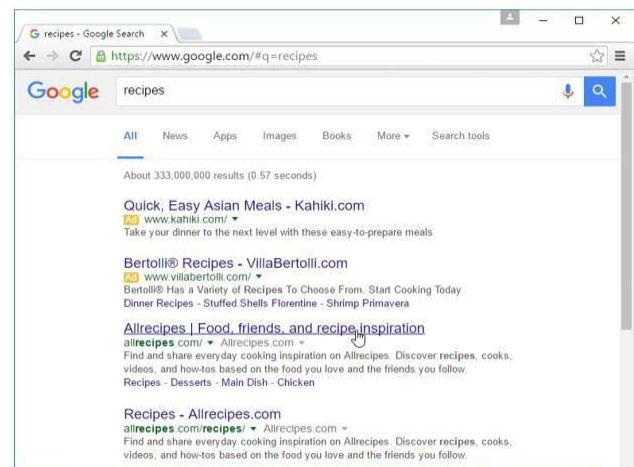

Fig Search Engine Format with Keyword or URL

2. The Search Engine Optimization

Process- SEO stands for search engine optimization, which is the process used to correctly adjust or optimize a technical configuration of websites, content relevance, and popularity, its pages may become easily

findable, more effectively relevant, and popular towards user search queries, as a consequence, search engine's platform ranks them better. The search engine recommends SEO efforts that benefit both the user search experience and the page visiting, by featuring content that fulfills user search needs. That includes the use of relevant keywords as a title or heading in the textbox, Meta delineation, featuring descriptive URLs with those keywords rather than strings of numbers, and schema markup to specify the page's content meaning, among other SEO better practices. Search engine optimization is the practice of orienting the website to rank higher on the search engine result page(SERP) so that users receive more traffic, it is assigned a numerical value to Webpages as a score based on a site's backlink profile. Google released the "PageRank toolbar" to publicly show any Page rank on a 0-100 scale. An increase in users' PageRank score meant that visited pages would be more likely to be placed the page at the top of the search engine results page (SERP). An aim is typically to rank on the first page of Google results for search terms that mean the most to users' target audience. That includes the use of relevant keywords as a title or heading in the textbox, Meta delineation, featuring descriptive URLs with those keywords rather than strings of numbers, and schema markup to specify the page's content meaning, among other SEO better practices. SOE is the practice of orienting the website to rank higher on the search engine result page(SERP) so that users receive more traffic, it is assigned a numerical value to Webpages as a score based on a site's backlink profile. Google released the "PageRank toolbar" to publicly show any Page rank on a 0-100 scale. An increase in users' PageRank score meant that visited pages would be more likely to be placed the page at the top of the search engine results page (SERP). An aim is typically to rank on the first page of Google results for search terms that mean the most to users' target audience.

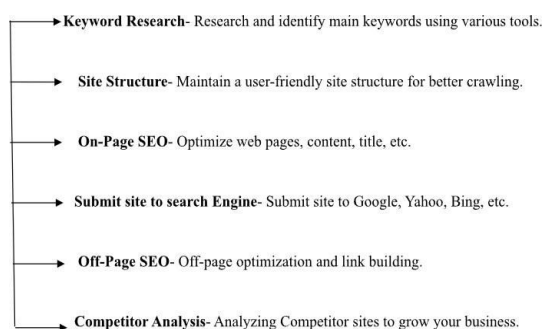

Fig: SEO Work Process with Different Tools.

3. WEB PAGES- Web pages are digital documents accessible through the World Wide Web and can be viewed by anyone connected to the network using a web browser. These pages serve as a gateway to various types of information, including text, images, videos, sounds, color schemes, graphics, animations, and more. The multimedia-rich content on web pages enhances the user experience, providing a diverse and engaging platform for information dissemination and interaction. This web page contains the information requested by the user and is displayed in the user's web browser in the respective format, whether it be text, images, videos, or other multimedia elements. This mechanism forms the basic foundation of how users interact with and retrieve information from the World Wide Web. Web pages are accessed and displayed online using web browsers such as Mozilla Firefox, Opera Mini, and Google Chrome, among others. These browsers connect to web servers via the HTTP (Hypertext Transfer Protocol) to retrieve website contents. Web servers host the digital information that comprises web pages. When users enter a URL or click on a link, the browser sends a request to the server, which responds by sending the web page. The web page is then visually and comprehensibly presented to the visitors, incorporating various types of digital information, such as text, images, videos, and other multimedia elements. It contains various components for good interaction with the user and specification-wise designed web pages that can be accessed easily. The components are virtual objects to display for specific purposes like the name of the website, search bar, navigation bar, heading of the page, the content of the page (paragraph, subheading, images), feedback or comment from a user, rating, social share link, copyright info, go to the top, advertisement manner, previous and next button or link, company info(about us). This web page is created using the HTML tag. Any person can easily create with different HTML tags.

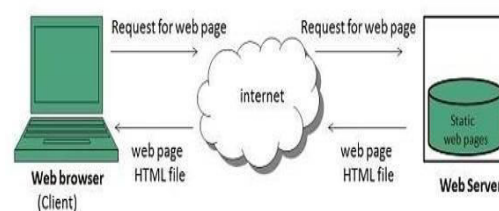
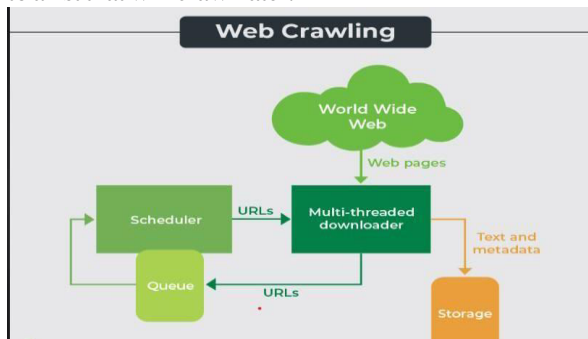

Fig. Request and response process through the Internet.

4. Crawling Technique- Crawling, also known as web crawling or spidering, is a technique used by search engines to systematically and automatically browse the internet, discover web pages, and index their content. This process is an essential part of how search engines gather and organize information to provide relevant search results.

1. Web Crawler or Spider or robot: In this, search engines send out a team of robots (also known as crawlers or spiders) to find new and updated content. Content can vary- that can be Web pages, images, videos, graphics pictures, animation, grid, table, PDF, documents or contents, etc., but regardless of the format, content is discovered by links and all possible by a crawling method. Always search engine wants crawlers or spiders (robots) to find relevant information regarding any subject matter on the World Wide Web. Help of this method, the machine can discover the existing to help identify the best web pages from the database. The programming mechanism of the crawler is based on the response of the sites, for example- HTTP 500 errors mean "slow down" and setting in the search console. At any time, a crawler looks at a webpage, they look through the Document Object Model (DOM) page to see what's on it. DOM is the HTML and Javascript code of the page that the crawlers look through to find the links to other pages. They are allowed to search engines to discover new pages on the web, every one of the new links they find is loaded in a queue that the crawler will visit at a present time. The search engine's crawler moves through user websites, it will also detect and record any links it finds on these pages and add them to a list that will crawl later.



2. Seed URLs- The crawling process typically begins with a set of seed URLs—initial web addresses that the web crawler uses to start its exploration. From these starting points, the crawler follows links to other pages. It is used to traverse to different sites.

Site	Author	Title	Tags	Description	Submission Time	Video Length	Recording Date	Comment	URL
whatsapp.com	Yes	Yes	Yes	Yes	Yes	Yes	Yes	No	No
youtube.com	Yes	Yes	Yes	No	No	Yes	Yes	Yes	Yes
music.com	No	Yes	Yes	Yes	No	Yes	Yes	Yes	Yes
tutorial.com	Yes	Yes	Yes	Yes	No	Yes	Yes	No	No
javapoint.com	Yes	No	Yes	No	No	Yes	Yes	Yes	Yes
coding.com	Yes	Yes	Yes	No	Yes	Yes	Yes	Yes	Yes

3. URL Discovery: As the web crawler visits a web page, it identifies and extracts hyperlinks present on that page. These links lead to other pages, allowing the crawler to discover new URLs to visit.

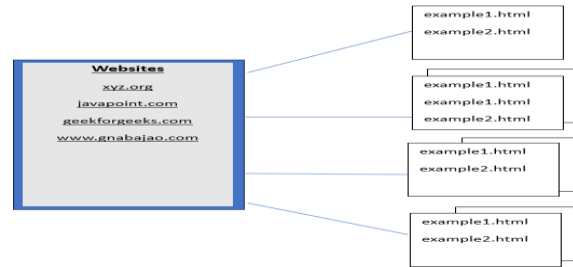

Fig: Redirected pages by various websites through hyperlinks.

4. Page Retrieval- Upon discovering a new URL, the web crawler sends a request to the web server hosting that page. The server responds by providing the content of the page, including text, images, and other media.

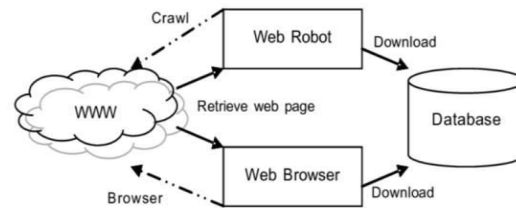

Fig: By Google requesting and responding through the database.

5. URL Frontier- The URLs discovered during the crawling process are added to a queue or "frontier" for subsequent visits. This ensures a systematic exploration of the web, covering a broad range of pages.

6. Depth -First or Breadth First Crawling: Crawlers can follow different strategies. Depth-first crawling involves exploring a single branch of links to a significant depth before moving to the next branch. Breadth-first crawling explores all links at the current depth level before moving to deeper levels.

7. Respecting Robots.txt- Web crawlers adhere to rules specified in a website's robots.txt file. This file instructs crawlers on which pages to crawl or avoid, respecting the website's guidelines.

8. Recrawled Frequency- Search engines periodically recrawl web pages to ensure that their index remains up-to-date. The frequency of recrawling depends on factors such as the importance and update frequency of the content.

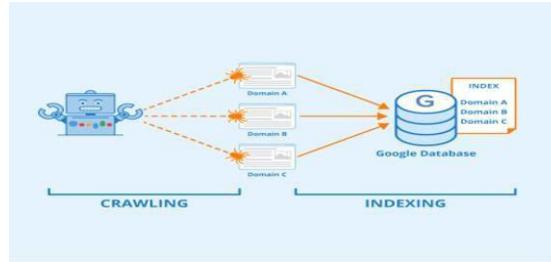

Fig Crawling and Indexing through Different Domains.

4. Index Technique- Google's index, often referred to as the Google index or Google's search index, is a massive database that contains information about web pages crawled by Google's web spiders. This index is what enables Google's search engine to quickly and efficiently respond to user queries by providing relevant search results. However, the specific details and inner workings of Google's index are proprietary and not publicly disclosed in their entirety. Indexing is the program used to search the website from several databases; its main purpose of indexing is storing and optimizing the speed in addition to the performance in finding the relevant documents for a search query. Whereas an index of 10000 documents can be queried within milliseconds, a sequential scan of every word in 10000 large documents could take hours. It is a process of building a structure that enables searching. Search engine indexing refers to the process where search engines organize and store online content in a central database or index form. Some popular search engines focus on the full-text indexing of online, natural language documents, and media types- such as video, pictures, animation changeable pictures, graphics, etc. The indexer always adds the reference document to the document list for the appropriate words. In a larger search engine, the process of finding each word in the inverted index may be too time-consuming or accessed by the user and this process is commonly split

into two parts, the first is the document and the second words.

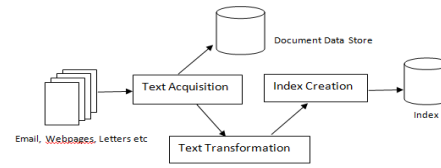

Fig. the Index Processing.

6. PageRank Algorithm- The PageRank algorithm (PR) or Google algorithm is used by Google Search to rank (rating) the Pages in their Google search engine results. This PR works by counting numbers and quality links to the pages to determine a rough estimate of how important the websites are. The basic assumption is that the most essential website is likely to receive more links from other websites. The rank values define the importance of a particular page. A hyperlink to a page counts as a vote of support or view from the user. It is defined recursively and depends on the number and PageRank matrices of all pages that link to it or "incoming call". A single web page linked to multiple web pages with high PageRank receives a high rank itself. The PR algorithm is also indicated as a link analysis algorithm and this assigns the number weighting to each element of a hyperlinked set of documents, such as a World Wide Web with the main purpose of "measuring" its relevant importance within a set. The Page Rank algorithm can be calculated for the collection of documents of any size as well as any format. PageRank computation requires several passes, called "iterations" through the collection to adjust approximate PageRank values more closely. Reflect the theoretical authenticate value illustration of the PageRank algorithm that the most significant percentage shows the perceived importance and those arrows represent the hyperlinks.

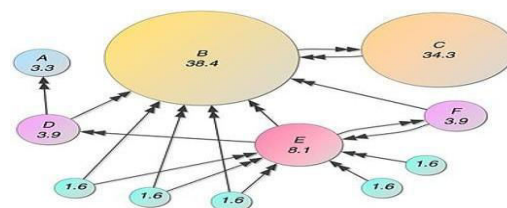

Fig: PageRank Algorithm (Rating wise sorted websites)

7. Database- The database is a collection of all confidential information that can be stored, retrieved, modified, and deleted as per the need.

The database is made of rows and columns in indexing form. A database of a search engine is a type of non-relational database dedicated to the search of data content. Search engine databases use indexes to categorize similar characteristics among data and facilitate searchability. These databases are optimized for dealing with data that may be long semi-structured or unstructured and they typically offer specific methods such as full-text-search, complex search expression, and ranking of search results. The databases allow logical queries such as the use of multi-field Boolean logic. "Crawling" or searching by a user is not necessary to find the information stored in the database because the data is already structured manner. Indexing data allows for faster searches. Here to access the database, have to go through three phases then various operations will be performed like retrieving, updating, storing, deleting, etc., because every stage has the given space to maintain all details of the activity & and that is the primary stage. This is the pre-developed structure for accessing the search engine. Database search engines are usually included with the major database software products (tools). As per the above topic discussed, controlling the interface or front page through the crawling technique, the next one is ranking- with the help of measuring or ranking of websites maintains the up-down scaling. The last one is the indexer-without this any stage will not show properly or cannot discover the most visited website. All have the space to maintain the record and this space is utilized by the database.

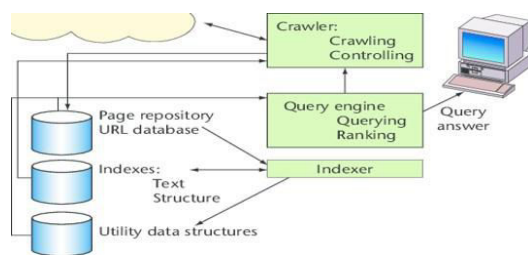

Fig: Query's answer fetching from Database.

8. Conclusion- Presenting the current tools and how we are using them in daily life, on a large scale. We envision that the scalability of web-searched pages will continue to be a research challenge for some more time for the new person. Summarize the key findings regarding current web search engines and their optimizations. Emphasize the need for ongoing

research to address scalability challenges and improve efficiency. This paper aims to provide a comprehensive overview of the current landscape of web search engines, emphasizing both the tools that shape our daily interactions and the ongoing efforts to enhance efficiency and scalability for a continually growing user base. One step toward that is to add an option for getting quick answers with one click. Some following points are discussed here to think about it.

- In all options, have a substitute option and add related basic concepts.
- It will be a saving process, and all topics are contained on one page.
- No one will be distracted and will not be redirected to another page.
- Segregate topics will be maintained on a single page as well as going to demanding sites.
- The time-consuming process will save here and quickly get the answer by this option.
- WWW contains a huge amount of data in its database, and using this sub-option can make fast access to their satisfaction.

BIBLIOGRAPHY

- 1) https://www.tutorialspoint.com/internet_technologies/web_pages.htm
- 2) https://www.researchgate.net/publication/226351869_Scalability_Challenges_in_Web_Search_Engines
- 3) https://www.ijmra.us/project%20doc/2018/IJMIE_MARCH2018/IJMRA-13333.pdf
- 4) <https://www.researchpublish.com/upload/book/Overview%20of%20Search%20Engine%20Optimization-8229.pdf>
- 5) <https://www.searchenginejournal.com/tutorial-for-beginners-7-steps-to-learn/469901/>
- 6) <https://www.searchenginejournal.com/anatomy-of-a-search-engine-crawler/2230/>

Wireless Sensor Network to Minimize Energy Consumption using Algorithm

Dr.P.R.Dike
Assistant Professor, SIT Lonavala
dikeprashant@gmail.com

Mr.Irfan Shaikh
SIT, Lonavala
neelamnab@gmail.com

Mr.Shubham Kumar
SIT, Lonavala
shubhamkumar15082003@gmail.com

Abstract— WSN is the fastest growing field in era of communication. The parameters that are to be focused are throughput and delay. Increasing throughput of system enhances performance of system. This paper addresses the issue related to throughput and provides improved algorithm for enhancement of parameters. In a multichannel network the selection of link rate is difficult. In this paper proposes a new network coding in WSN with the intention of maximizing the throughput of the network. Here, the improved meta-heuristic algorithm called modified Lion Algorithm (LA) will be used to solve the problem of network coding in WSN.

Keywords—Multirate, Lion algorithm (LA), Distribution link rate (DLR), Triangular network coding (TNC), Electromagnetic (EM).

I. INTRODUCTION

Wireless Sensor Networks (WSNs) enjoy great benefits due to their low-cost, small-scale factor, smart sensor nodes. Not only can they be employed in cumbersome and dangerous areas of interest, for monitoring or controlling the regions. Recently, WSN have attracted much interest to develop for various applications such as environmental monitoring, military reconnaissance, target tracking, health, surveillance and robotic exploration etc [13]. A WSN consists of low powered sensors, which have sensing, processing and communication capabilities.

Improving energy efficiency and decreasing energy consumption are still a main challenge of WSNs. Energy-efficient technique, such as the network coding, have received extensive attention from industrial and academic societies to decrease energy consumption and improve network performance [14]. Network coding is a technique in which different mathematical operations are used to combine different nodes, which reduces the number of transmitted packets. Network coding was first proposed for wired networks to solve the bottleneck problem and to increase the throughput [18]. Network coding gives required change in the wireless network by using broadcast nature of

wireless sensor network channels. Moreover, it tends to reduce power consumption in comparison with the traditional simple store-and forward approach [15]. Network which uses coding techniques permits different nodes to encode different incoming packet instead of just forwarding them. This powerful theory can improve the network load and enhance network robustness by employing path diversity. So, in addition to prolonging the lifetime of WSNs, NC improves data security. As a result, NC for exploiting the correlations of sensor readings in WSNs has become an attractive topic [5] [17].

The majority of the NC schemes in use nowadays have their basis in algebraic theory [21] [25]. Whereas earlier schemes, such as the traditional XOR-coding scheme and the Deterministic Linear Network Coding scheme were deterministic in nature, the more common schemes in use today are non-deterministic, meaning they are free from the constraint of having packet feedback information for every transmitted packet from all the receivers [19]. In this section we shall take a look at some common coding schemes, namely Random Linear Network Coding (RLNC), Triangular Network Coding (TNC) and Opportunistic Network Coding (ONC). Physical-layer network coding as a concept was proposed in 2006 for application in wireless networks. PNC main idea is to take advantage of the natural network coding operation that occurs when electromagnetic (EM) waves are superimposed on one another [22] [23]. This simple idea leads to numerous advancements, with subsequent works by various researchers leading to many new results in the domains of wireless communication, wireless information theory, and wireless networking [24]. With this in mind, PNC is the future of NC in wireless networks and thus it is

important we understand it. Further, researches are still going on in the field of implementing network coding in WSN for the betterment and new innovation.

II. RELATED WORK

In 2017, Dermany *et al.* [1] have defined an energy consumption optimization problem in WSNs, in which the network concurrently uses topology control as well as network-coding-based multicasting. The constructed problem of optimization was converted into a convex problem, resulting in various conceptual and theoretical benefits. Further, the Karush-Kuhn-Tucker (KKT) optimality criteria were provided in order to obtain analytical representations of the global optimal outcome. The outcomes of simulation proved that the suggested approach has considerably lower consumption of energy compared to conventional ones and reduces end-to-end delay.

In 2013, Vieira *et al.* [2] have explored the relationship in multi-hop wireless networks among link-layer transmission rate diversity and network coding. A linear programming model was suggested for determining the maximum throughput in a rate-diversity wireless network, in which a multicast system can attain with network coding. The experiment was carried out and the results were noticeably better quality than conventional routing. Therefore, combining network coding and multi-rate diversity has provided a greater opportunity to achieve high throughput.

In 2019, Dermany *et al.* [3] have suggested an optimization problem where it can make it easier to find lifetime optimal topology control in network-coding-based-multicast-WSN. In regards to the transmission power, the energy consumed for reception was also viewed in the suggested mathematical model. Moreover, in order to catch much more specific situation, different aspects of the issue were considered. It was proved that the suggested objective function's second derivative matrix (Hessian matrix) was not semi-definite positive and came to the conclusion that the proposed optimization model was non-convex non-linear programming. A genetic algorithm was utilized to speed up the discovery of a solution that can look for the optimal strategies. Finally, the

findings of experiment have shown that in network-coding-based multicast WSNs, the suggested algorithm has effectively achieved the optimum or close-optimal topology. Furthermore, the simulations indicate that the suggested algorithm was capable of extending the lifespan when compared over different existing approaches.

In 2019, Mothku and RanjanRout [4] have developed a method for a WSN with defective nodes named as reliable data transmission method using opportunistic encoding. A network coding strategy was intended to attain reliable data transmission by recognizing connection failure levels and an adequate level of redundancy. In addition, a Markov Decision Process (MDP) was introduced for opportunistic decision-making of network coding. The developed mechanism determines the amount of packet redundancy to enhance reliable data compilation and lower the amount of data transmissions in the network coding process. Furthermore, the effectiveness of the developed mechanism was demonstrated via simulation outcomes, taking into account the average delivery delay, energy consumption, number of data transmissions, and lifetime of the network.

In 2016, Chen *et al.* [5] have established a clustered spatio-temporal compression scheme by incorporating network coding, compressed sensing, and spatio-temporal compression for correlated data, taking into account the temporal as well as spatial correlations of sensor readings in WSNs. An innovative optimization model of reconstruction error for the clustered spatio-temporal compression scheme was constructed to further minimize the reconstruction error. To find the optimum solution iteratively, a distributed algorithm was established. At last, the experimental outcomes have determined that the clustered spatio-temporal compression scheme dominates other two compression methods in aspects of recovery error as well as compression gain considerably, and the distributed algorithm scales linearly with a rapid and stable speed to attain the optimal outcome.

In 2016, Yin *et al.* [6] have recommended a far more deliberate system coupled with Compressed Sensing. It was noted that WSNs frequently determine physical signals showing a

large degree of correlation. According to the recommended method of measurement and recovery, it shows that the original data can be slowly retrieved while retaining the NC-based system benefit. The comparative evaluation of the developed system together with other existing systems was presented by demonstrating the efficiency as well as robustness.

In 2016, Ding *et al.* [7] have dedicated to study a high-performance protocol called NCCM-DC, a cluster-level multipath protocol focused on network coding in Duty-Cycled WSNs. The nodes were grouped into such a cluster in the NCCM-DC protocol and also the cluster was used as a basic unit for building the multipath. Furthermore, NCCM-DC enhances transmission reliability with both the benefit of path redundancy as well as network coding. To maximize energy efficiency, the method of dormancy and the algorithm of collaborative state transition were been focused. NCCM-DC was suitable to energy-limited WSNs because of the affordable prices in the routing discovery phase and also the arbitrary coding coefficient operations in Galois Field. The conceptual analysis and experimental outcomes confirms the capacity of NCCM-DC to satisfy network reliability as well as energy efficiency requirements.

III.PROPOSED WORK

Coding of network and change in the rate are the important parameters for enhancement of throughput and delay. Combining network coding and diverse rate increases potential gain. Wireless topology with number of nodes is as shown in Fig. 1. No.of nodes considered are five. The path between node 1 and 2 is 1 Mbps.The path between the other points are 11Mbps. Both the positions 1 & 2 transmit the information A and B respectively. In a wireless transmission, the links are not independent. Node 1 also transmits data to node 3 with the same rate. Similarly node 1 sends data to node 4 with the same rate. The size of data is assumed to be 11 MBPS for all the nodes.

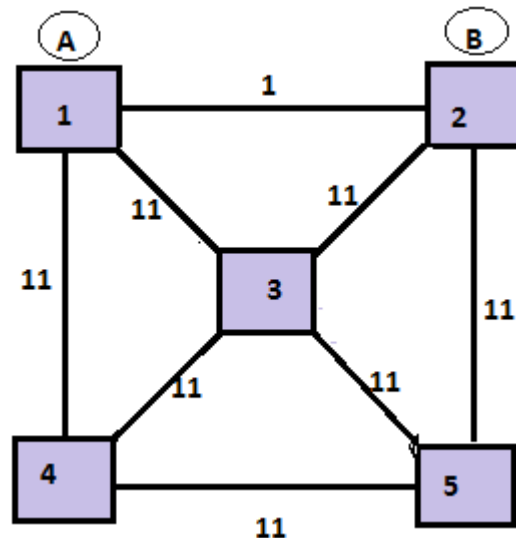

Fig.1. A multi-rate network example

For transmitting information from A and B from position 1 and 2 there are three different ways. These techniques shows that network coding and diverse rate in combination enhances throughput and delay. It also increases energy efficiency with the combination of change in rate and network coding.

- First consider data sending with diverse rate unaware without Network Coding
- Second technique data sending with change in rate with no Network Coding
- Third technique data sending with rate diversity aware with network coding.

When transforming information from position 1 to 4 for position 2 it is not possible to transform the information to 3 as position 3 is on the same range from 1 and 4.it is shown in fig.2.

The time required for sending node 1 data to node 2, 3, 4 is approximately 11 unit. The time required for sending node 2 data to node 1, 3, 5 is approximately 11 unit. Position 3 transforming information B to position 4 and time required is 1 unit.

Node no 3 data packet A to node 5 and time required is 1 time units.

The time required to complete operation is 24 time unit.

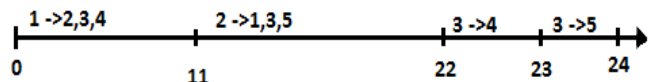

Fig.2 Data sending without network coding

Network coding and rate diversity enhances time and throughput.

Third node transmit A XOR B to node 4 and 5 in a single transmission.

Four no node has data related to A and can get data packet B from XOR operation. Node no 5 has data related B and can get data packet A from XOR operation. By using network coding the time is minimized by unit 1 shown in fig.3

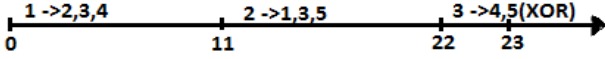

Fig.3 Data sending with change of rate with no Network coding

Different nodes has different ways to adopt their rates. The total time required for sending data packet is only 4 units

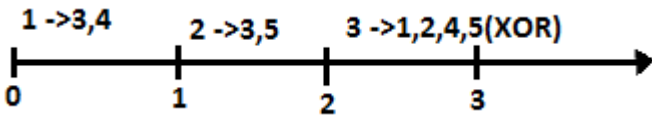

Fig.4 Data sending with network coding

Combination of network coding and diverse ate enhances the time by 3 unit. Network coding Time decreases to 3 as added network coding and rate diversity.

The information packet which is sent from node 1 to A with the rate of 11 Mbps.

The information packet from node 2 is sent to B to 3 and 5 with rate of 11 Mbps.

Then node 3 sends (at 11 Mbps) the XOR message to 4 and 5, and also to 1 and 2.

With XOR operation node 1 will get information of B.

The tabular explanation is given in table 2.

Node transformation	Change of rate and no network coding	Change of rate with network coding	rate diversity-aware with Network Coding
From 1 to 2,3,4	Total time – 24 unit	Total time – 23 unit	Total time – 3 unit (X-OR)
From 2 to 1,3,5			
From 3 to 4			
From 4 to 5			

In communication usually power consumption plays an important role so there are some ways such as control on topology used and coding in network, to decrease the activity of sensors transceivers. If such techniques are utilized simultaneously, then

the overall performance does increase as expected. In WSN, the linear network coding has been shown to improve the performance of network throughput and reduce delay. However, the network coding condition of existing network coding aware routings may experience the problem of false-coding effect in some scenarios, and usually neglect node energy, which greatly influences the energy efficiency performance. Hence, this paper proposes a new network coding in WSN with the intention of maximizing the throughput of the network. Here, the improved meta-heuristic algorithm called Improved Lion Algorithm (LA) will be used to solve the problem of network coding in WSN. The main intention of implementing improved optimization is to maximize the throughput of the network from source to destination node. While solving the current optimization problem, it has considered few constraints like time share constraint, data-flow constraint, and domain constraint. Thus, the multi-rate link layer broadcasts and network coding can be mutually combined with new optimization algorithms for enhancing the network throughput. The proposed flow diagram is shown in Fig. 5.

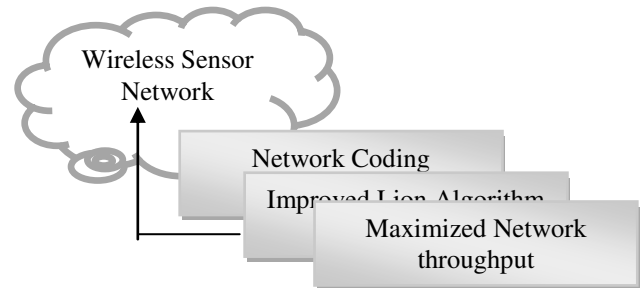

Figure 5: Flow Diagram of Proposed Model

IV.RESULTS

Proposed work was carried out using MATLAB and results are compared with some of the existing systems. The simulation area was taken as 100m x 100m. Different nodes configuration are taken for calculating throughput of system using proposed algorithm. The values of energy minimization are compared with proposed system algorithm. Number

of nodes used for performance comparison is 20. It is proved from proposed algorithm that at 500 iteration we got best result from improved lion algorithm as shown in fig.7.

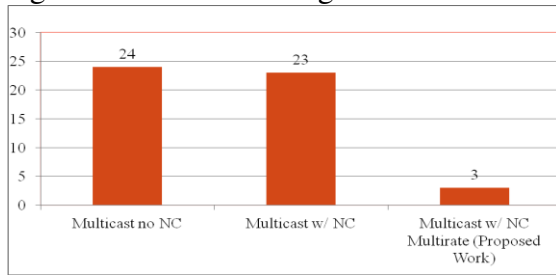

Fig.6 comparison of time

The performance of the proposed algorithm in fig.7 is compared with existing partial swarm optimization (PSO), Firefly (FF), Grey wolf optimization (GWO) and lion algorithm (LA).

Sr.no	Compared with algorithm	Better performance in %
1	FF	48.00%
2	PSO	55.17%
3	GWO	38.09%
4	LA	1%

Performance table using proposed algorithm

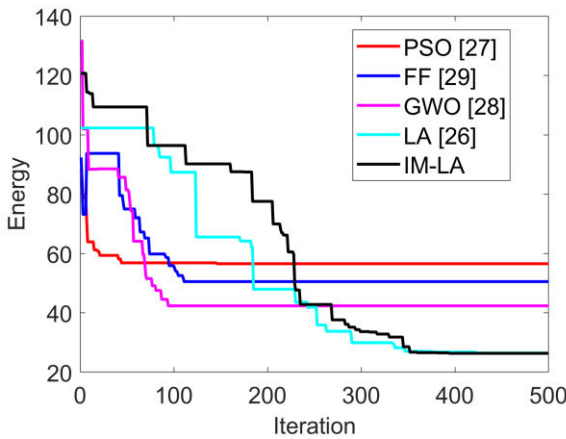

Fig.7 comparison of energy minimization

From the results performance of the proposed system is better as compared to existing algorithms as throughput is concerned.

V.CONCLUSION

Network coding with multirate data system increases the throughput of system was proved by using proposed algorithm. It was also proved that for at 500 iteration results found were best compared to existing system. The performance of proposed algorithm is compared with existing partial swarm optimization (PSO), Firefly (FF),

Grey wolf optimization (GWO) and lion algorithm (LA).The main purpose of proposed algorithm was to minimize delay and increase in throughput of the system. Results taken from this paper are greatly useful for future enhancement in network coding and change in rate of coding. In this paper we have proved that combining network coding and change in the rate can increase throughput of network in different applications.

REFERENCES

- [1] M.Khalily-Dermany, M.Shamsi and M.J.Nadjafi-Arani, "A convex optimization model for topology control in network-coding-based-wireless-sensor networks," *Ad Hoc Networks*, vol. 59, pp. 1-11, 1 May 2017.
- [2] Luiz Filipe M.Vieira, MarioGerla and ArchanMisra, "Fundamental limits on end-to-end throughput of network coding in multi-rate and multicast wireless networks," *Computer Networks*, vol. 57, no. 17, pp. 3267-3275, 9 December 2013.
- [3] M.Khalily-Dermanya, M.J.Nadjafi-Arani and S.Doostali, "Combining topology control and network coding to optimize lifetime in wireless-sensor networks," *Computer Networks*, vol. 162, 24 October 2019.
- [4] Sai Krishna Mothku and Rashmi RanjanRout, "Markov decision process and network coding for reliable data transmission in wireless sensor and actor networks,"*Pervasive and Mobile Computing*, vol. 56, pp. 29-44, May 2019.
- [5] Siguang Chen, Chuanxin Zhao, Meng Wu, Zhixin Sun, Haijun Zhang and Victor C.M.Leung, "Compressive network coding for wireless sensor networks: Spatio-temporal coding and optimization design," *Computer Networks*, vol. 108, pp. 345-356, 24 October 2016.
- [6] Jun Yin, Yuwang Yang, Lei Wang and Xiaoyong Yan, "A reliable data transmission scheme based on compressed sensing and network coding for multi-hop-relay wireless sensor networks," *Computers & Electrical Engineering*, vol. 56, pp. 366-384, November 2016.
- [7] Xu Ding, Xinjiang Sun, Cheng Huang and Xiaobei Wu, "Cluster-level based link redundancy with network coding in duty cycled relay wireless sensor networks," *Computer Networks*, vol. 99, pp. 15-36, 22 April 2016.
- [8] K. Eritmen and M. Keskinöz, "Improving the Performance of Wireless Sensor Networks Through Optimized Complex Field Network Coding," *IEEE Sensors Journal*, vol. 15, no. 5, pp. 2934-2946, May 2015.
- [9] A.-S. Tonneau, N. Mitton, J. Vandaele, How to choose an experimentation platform for wireless sensor networks? A survey on static and mobile wireless sensor network experimentation facilities, *Ad Hoc Networks*. 30 (7) (2015) 115–127. doi:10.1016/j.adhoc.2015.03.002.
- [10] L. Borges, F. Velez, A. Lebez, Survey on the Characterization and Classification of Wireless Sensor Networks Applications, *IEEE Commun. Surv. Tutorials*. 16 (4) (2014) 1860–1890. doi:10.1109/COMST.2014.2320073.
- [11] J.-Y. Lee, W.-J. Kim, J.-Y. Baek, Y.-J. Suh, A Wireless Network Coding Scheme with Forward Error Correction Code in Wireless Mesh Networks, in: *Proceedings of the Globecom'09, 2009*, pp.1–6. doi:10.1109/GLOCOM.2009.5426042.
- [12] F. Jalali, S. Khodadoustan, A. Ejlali, Cooperative Hybrid ARQ in Solar Powered Wireless Sensor Networks, *Microelectron. Reliab.* 52 (12) (2012) 3043–3052. doi:10.1016/j.microrel.2012.07.009.
- [13] I.F.Akyildiz et.al, "A survey on sensor networks" *IEEE Communication Mag.*, vol.40, no.8, pp. 102- 114, Aug 2002.
- [14] H. Karl, A. Willig, *Protocols and architectures for wireless sensor networks*, John Wiley & Sons, 2007. doi:doi:10.1002/0470095121.
- [15] S. Katti, H. Rahul, W. Hu, D. Katabi, M. Medard, J. Crowcroft, Xors in the air: practical wireless network coding, *IEEE/ACM Transactions on Networking (ToN)* 16 (3) (2008) 497–510. doi:http://dx.doi.org/10.1109/tnet.2008.923722.
- [16] R. Ahlswede, N. Cai, S. R. Li, and R. W. Yeung, "Network information flow," *IEEE Trans. Inf. Theory*, vol. 46, no. 5, pp. 1204-1216, Jul. 2000.
- [17] Rashmi Ranjan Rout and Soumya K.Ghosh,"Adaptive data aggregation and energy efficiency using network coding in a clustered wireless sensor network: An analytical approach," *Computer Communications*, vol. 40, pp. 65-75, 1 March 2014.

- [18] Mustapha Reda Senouci, Abdelhamid Mellouk, Hadj Senouci and AmarAissani, "Performance evaluation of network lifetime spatial-temporal distribution for WSN routing protocols," *Journal of Network and Computer Applications*, vol. 35, no 4, pp. 1317-1328, July 2012.
- [19] Baolin Sun, Chao Gui, Ying Song and Hua Chen, "A Novel Network Coding and Multi-path Routing Approach for Wireless Sensor Network," *Wireless Personal Communications*, vol. 77, no. 1, pp 87–99, July 2014.
- [20] Ying Liu, Zhen Yang, Zhonghui Mei and Yuanyuan Kong, "Research on adaptive compression coding for network coding in wireless sensor network," *Journal of Electronics*, vol. 29, no. 5, pp 415–421, September 2012.
- [21] D. Ferreira Lima and J. Roberto Amazonas, "TCNet: Trellis Coded Network - Implementation of QoS-aware Routing Protocols in WSNs," *IEEE Latin America Transactions*, vol. 11, no. 3, pp. 969-974, May 2013.
- [22] Z. Faraji-Dana and P. Mitran, "On Non-Binary Constellations for Channel-Coded Physical-Layer Network Coding," *IEEE Transactions on Wireless Communications*, vol. 12, no. 1, pp. 312-319, January 2013.
- [23] L. Yang, T. Yang, J. Yuan and J. An, "Achieving the Near-Capacity of Two-Way Relay Channels With Modulation-Coded Physical-Layer Network Coding," *IEEE Transactions on Wireless Communications*, vol. 14, no. 9, pp. 5225-5239, Sept. 2015.
- [24] Q. Yang and S. C. Liew, "Asynchronous Convolutional-Coded Physical-Layer Network Coding," *IEEE Transactions on Wireless Communications*, vol. 14, no. 3, pp. 1380-1395, March 2015.
- [25] S. Lin, L. Fu, J. Xie and X. Wang, "Hybrid Network Coding for Unbalanced Slotted ALOHA Relay Networks," *IEEE Transactions on Wireless Communications*, vol. 15, no. 1, pp. 298-313, Jan. 2016.
- [26] Rajakumar Boothalingam, "Optimization using lion algorithm: a biological inspiration from lion's social behavior", *Evolutionary Intelligence*, vol.11, no.1–2, pp. 31–52, October 2018.
- [27] Kennedy J, Eberhart R (1995) *Particle swarm optimization*. In: *Proceedings of IEEE international conference on neural networks, IV, pp 1942–1948*. <https://doi.org/10.1109/ICNN.1995.488968>
- [28] Yang X-S (2010) *Nature inspired metaheuristic algorithms, 2nd edn*. Luniver Press, London
- [29] Mirjalili SM, Mirjalili A, Lewis (2014) *Grey wolf optimizer*. *Adv Eng Softw* 69:46–61

Enhancing Agricultural Productivity through NDVI Precision Farming for Sustainable Crop Management

Prof. Sandhya Deshpande
Faculty of EXTC Engineering
K J Somaiya Institute of Technology
Sion (Mumbai), India
sandhya.d@somaiya.edu

Ms. Supriya Suresh Nakade
Student of EXTC Engineering
K J Somaiya Institute of Technology
Sion (Mumbai), India.
supriya.nakade@somaiya.edu

Mr. Aniket Amit Velankar
Student of EXTC Engineering
K J Somaiya Institute of Technology
Sion (Mumbai), India.
aniket.velankar@somaiya.edu

Mr. Nikunj Ashok Panchal
Student of EXTC Engineering
K J Somaiya Institute of Technology
Sion (Mumbai), India.
nikunj.ap@somaiya.edu

Abstract - Land Use and Land Cover (LULC) analysis provides critical insights into the changing landscape and environmental dynamics of a region. Land is a finite resource. There is a need for optimal utilization of land resources. Optimal utilization of land resources can be achieved through scientific land use planning. This study aims to generate land use land cover information using Remote sensing and Geographical Information System (GIS) technology to support the land use planning and strategy formulation of the newly emerging problem of the study area. Junnar City of Pune district (Maharashtra, India) covering longitude approximately ranges between 83°18'0"E to 83°29'0"E and latitude approximately ranges Between 73.7° E to 74.1° E and total area of Junnar in hectares is approximately 2,600 square kilometers or 260,000 hectares had been taken as a study area. The country can no longer afford to neglect land, the most important natural resource, so as to ensure agricultural sustainability and avoid adverse land use conflicts.

Keywords- NDVI, QGIS, BHUVAN open source, ISRO, Land use Land cover.

I. INTRODUCTION

Land use and land cover change (LULC) is a complex process influenced by natural and human activities. Due to the growing population and increasing human development, more and more land is being converted into urban and industrial areas, affecting the environment. LULC change shows how the way we use and cover land evolves over time. Land Use Plans (LUPs) are critical to managing our natural resources, especially when there are conflicts and competing interests in land use. It helps to resolve conflicts and is a sustainability goal. Understanding and managing LULC changes is critical to improving our quality and value of life. This understanding must occur at the local, regional and global levels, and questions such as where, when and how are these changes occurring must be asked. Effective land use planning is essential to reduce negative impacts on the environment and promote sustainable use of resources

for the benefit of future generations. Advanced remote sensing technologies such as Landsat Multispectral Scanner (MSS) and Thematic Mapper (TM) have been widely used to monitor these changes since 1972. Software tools such as ArcGIS and ERDAS support spatial and non-spatial search and retrieval information for better decision making.

II. STUDY AREA

Junnar Tahsil is situated in the northern zone of the Pune district. It lies in the section of steep slope having rainfall around 50 to 250 cm. The extent of the Tahsil is 19° 00' N to 19° 24' N and 73° 40' E to 74° 18' E. The area of the Tahsil is 1474.77 Sq.km. Junnar is mainly rural in character as are there 183 villages. Junnar Tahsil has the human population as about 3, 99,302. The rural population is 93.66 %, while the urban population is 6.34 %. Junnar, Nimgaonsava, Otur, Belhe, Aptale, Narayangaon, Vadgaon Anand, Dingore and Rajur are nine circles in the Junnar Tahsil. The total area under the crops covers 56287.15 ha. The Tahsil has 67 villages categorized as tribal villages in which the development is on lower side. Further, spatial variations in regional development have been significant in the Junnar Tahsil. The Tahsil has mainly agriculture as the major source of income. Therefore it is interesting to study the facts and factors related to crop combination pattern of different crops in the Tahsil.

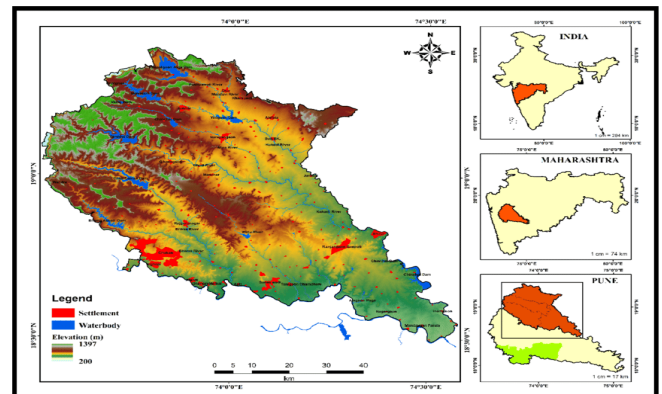

III. SCOPE OF THE REVIEW

The integration of NDVI precision farming techniques within the scope of Land Use/Land Cover (LULC) analysis has significantly contributed to enhancing agricultural productivity and sustainable crop management practices. LULC analysis, when combined with NDVI data, enables a comprehensive understanding of the landscape, including the identification of different land uses and covers within an agricultural area. This integrated approach allows for precise monitoring of changes in vegetation health, land productivity, and environmental impacts caused by shifts in land use or cover types. By analyzing NDVI data alongside LULC information, farmers and land managers gain insights into optimizing crop distribution, improving resource allocation, and implementing tailored land management strategies, thereby fostering more sustainable agricultural practices while maximizing productivity within specific land cover categories. The amalgamation of NDVI precision farming with LULC analysis provides a holistic framework for informed decision-making, promoting efficient land use and environmental conservation in agriculture.

IV. SOFTWARE

Bhuvan

Satellite Imagery:- Bhuvan is an online geoportal developed by the Indian Space Research Organisation (ISRO), providing satellite imagery and various geospatial data of India. It offers multi-resolution, multi-sensor, multi-temporal imagery of different regions in India. However, as an AI language model, I don't have real-time browsing capabilities or direct access to external websites, including Bhuvan.

Thematic Maps:- Bhuvan offers thematic maps that display specific information related to various sectors such as agriculture, forestry, water resources, urban planning, and more. These maps often incorporate data layers, highlighting specific aspects of the geographical region, such as land use, soil information, vegetation, and infrastructure.

Base Maps:- Bhuvan includes base maps that offer basic reference information, including political boundaries, road networks, and geographical features. These base maps serve as a foundation for overlaying additional data or thematic layers.

Dynamic Maps:- Users can access dynamic maps that allow for the overlay of different layers or data sets on top of the base maps or satellite imagery. This functionality enables the customization and visualization of multiple data layers simultaneously.

Visit the Bhuvan website at <https://bhuvan.nrsc.gov.in/>.



Future Directions:-

Technological Advancements:- The continuous development of technology is essential for the future of NDVI precision farming. In this section, explore the potential technological advancements:

Enhanced Remote Sensing Platforms:- Discuss how advancements in remote sensing technology, including more capable satellites and sensors, can lead to higher-resolution and more frequent data acquisition.

Machine Learning:- Explain the role of machine learning in processing and interpreting NDVI data, enabling more accurate and automated decision support.

Sensor Miniaturization:- Address the potential for smaller, more affordable sensors and drones, making NDVI technology accessible to a wider range of farmers.

Data Accessibility:- Emphasize the importance of open data initiatives and data-sharing platforms to make NDVI data more accessible to all stakeholders.

Data Source:- The primary data collected from different sources include satellite imagery, statistical handbooks of Junnar 2000 & 2010, information from local experts and surrounding community members. The secondary data such as a topographic map and some instruments like digital camera, compass and tape used to collect the field data. The software Arc GIS 9.0 and ERDAS 9.2 had been played a vital role in the demarcation of wastelands. Before the fieldwork, the necessary satellite imagery such as Landsat TM, MSS

2000 and TM 2010 was downloaded from USGS (United States Geological Survey).

QGIS

- QGIS (Quantum Geographic Information System) is a free, open-source software that allows users to create, edit, visualize, analyse, and publish geospatial information.
- Quantum GIS (QGIS) provides a comprehensive set of tools for working with geospatial data and creating maps. QGIS is known for its user-friendly interface, powerful capabilities, and extensibility.
- QGIS is a powerful and versatile GIS software application that caters to a wide range of geospatial needs, from basic map creation to advanced spatial analysis.
- QGIS is a robust and highly customizable GIS software application.

Key features and aspects of QGIS

Open Source: QGIS is open-source software, which means it is freely available for anyone to download, use, modify, and distribute. This open nature fosters a large and active user community and encourages collaborative development.

Cross-Platform: QGIS is available for multiple operating systems, including Windows, macOS, Linux, and BSD, making it accessible to users on different platforms.

User-Friendly Interface: QGIS offers an intuitive and user-friendly graphical interface. Its interface is similar to many commercial GIS software, making it easy for users familiar with other GIS tools to transition to QGIS.

Data Compatibility: QGIS supports various data formats, including shapefiles, GeoJSON, GeoTIFF, PostGIS, and more. This flexibility allows users to work with data from diverse sources.

Geospatial Analysis: QGIS provides a comprehensive set of geospatial analysis tools for tasks such as spatial querying, buffering, overlay operations, terrain analysis, and more. It supports both vector and raster data analysis.

Map Design: Users can create high-quality maps with QGIS, customizing layouts, symbols, labels, and legends to meet specific needs. It's a valuable tool for cartography, including the creation of thematic maps.

V. METHODOLOGY

The following steps had been followed in the methodology

1. INPUTS

- Toposheets
- Satellite Imageries (8-band Landsat-7) 2000 & 2010

2. PROCESS

Geo-Rectification of Topo sheets

- Un-Supervised Classification
- Field visit (for Ground Truth)
- Supervised Classification

- Authentication with Statistical Handbook of the District
- Finalizing the Classes
- Delineation of Wastelands from both 2000 & 2010
- Classifying the Wastelands 3. OUTPUT
- Land use Land cover classes
- Waste Land demarcation
- Change Analysis

Initially, unsupervised classification was carried out to get some valuable information about the different land cover classes. After that, a field survey had been carried out and this data used in supervised classification for a better understanding of land covers. A total of 10 land use land cover classes were finalized and change analysis carried out between the years 2000 and 2010.

VI. RESULT AND DISCUSSION

The results of the land use and land cover classifications shown below. From the independent image classification resulting from the two satellite images. Ten different land use and land cover (LULC) categories were identified. It covered 260,000 hectares of the total study. Cultivated land is 35,638 hectares and uncultivated land is 224,362 hectares Covered throughout the area and covered 3.67 %.

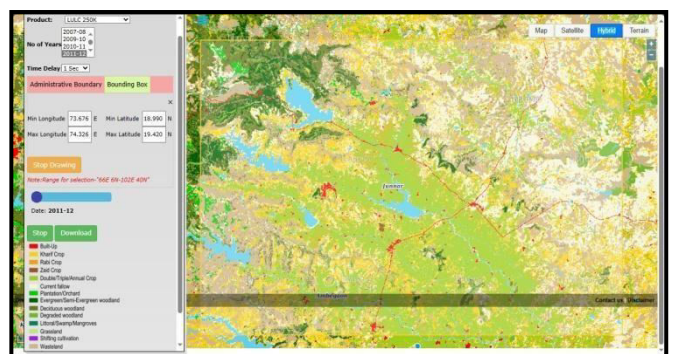
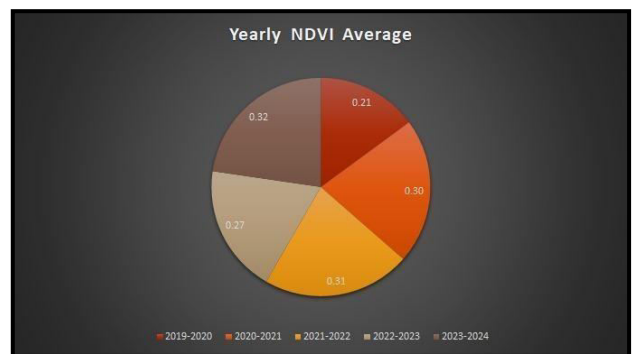

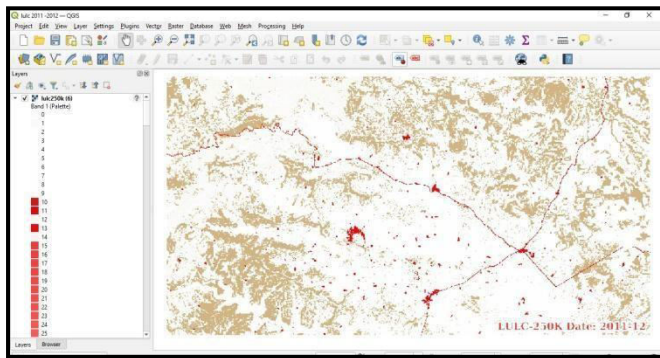

VII. CONCLUSION

So, we have compare the data from ISRO , Bhuvan, and some part from google earth pro, and data we have acquired data from all the website/software. The Pune-junner District on QGIS software edited and created new map on QGIS software which including land use and land cover (LULC) –Agriculture land in use and land not in use. This created map by our team is use for understanding people that a particular land in junner is use or not. If not then we checked weather this land is Re- Agriculture or not If not then we can suggest commercial area or green house area on that particular land.

VIII. SCOPE FOR FURTHER STUDY

Using the latest surveying equipment and skilled teamwork, the Land use Land cover classification results will be achieved by 100%. Hence a detailed study with sophisticated equipment is suggested along with GIS techniques.

IX. REFERENCES

Land Use Land Cover (LULC) classification with wasteland demarcation using Remote sensing andGIS Techniques

Malthus, T. R. (1798). An Essay on the Principle of Population. J. Johnson.

Rouse, J. W., & Haas, R. H. (1973). Monitoring vegetation systems in the great plains with ERTS. In Third Earth Resources Technology Satellite-1 Symposium - Greenbelt, MD (Vol. 1, pp. 309-317). IEEE.

Hatfield, J. L., Gitelson, A. A., Schepers, J. S., Walthall, C. L., & Myrick, R. L. (2008). Application of spectral remote sensing for agronomic decisions. *Agronomy Journal*, 100(1), 117-131. DOI: 10.2134/agronj2007.0145

Thenkabail, P. S., Smith, R. B., & De Pauw, E. (2000). Hyperspectral vegetation indices and their relationships with agricultural crop characteristics. *Remote Sensing of Environment*, 71(2), 158-182. DOI: 10.1016/S0034-4257(99)00067-X

Zaman, Q. U., Schumann, A. W., & Searcy, S. W. (2018). NDVI-based agricultural crop yield monitoring and

forecasting: A United States Department of Agriculture (USDA) and State Cooperative Extension Service (CES) partnership. *Computers and Electronics in Agriculture*, 154, 408-424. DOI: 10.1016/j.compag.2018.09.034

Lobell, D. B., & Burke, M. B. (2010). On the use of statistical models to predict crop yield responses to climate change. *Agricultural and Forest Meteorology*, 150(11), 1443-1452. DOI: 10.1016/j.agrformet.2010.07.008

Friedrich, T., Dercon, S., & Outes-Leon, I. (2019). Subjective Economic Well-being: Panel Evidence from Developing Countries. *Journal of Economic Behavior & Organization*, 161, 161-174. DOI: 10.1016/j.jebo.2019.02.006

Fingerprint Based Electronic Voting Machine

BHAKTI PANSARE

DEPARTMENT OF ELECTRONICS ENGINEERING
DATTA MEGHE COLLEGE OF ENGINEERING
AIROLI, NAVI MUMBAI

ADITYA BHAGWAT

DEPARTMENT OF ELECTRONICS ENGINEERING
DATTA MEGHE COLLEGE OF ENGINEERING
AIROLI, NAVI MUMBAI

DINESH MISTRI

DEPARTMENT OF ELECTRONICS ENGINEERING
DATTA MEGHE COLLEGE OF ENGINEERING
AIROLI, NAVI MUMBAI

PROF. SURESH JAJOO

DEPARTMENT OF ELECTRONICS ENGINEERING
DATTA MEGHE COLLEGE OF ENGINEERING
AIROLI, NAVI MUMBAI

ABSTRACT

Fingerprint-based voting machines have emerged as a promising solution to enhance the security and efficiency of the electoral process. This technology utilizes biometric authentication to ensure the legitimacy of voters and prevent fraudulent activities, thereby fostering transparent and fair elections. By integrating advanced fingerprint recognition algorithms, these machines authenticate voters' identities swiftly and accurately, eliminating the risks associated with duplicate or forged votes. Moreover, the implementation of such systems minimizes the logistical challenges related to traditional voting methods, streamlining the overall voting process. This paper investigates the design and

implementation of a fingerprint-based voting machine, emphasizing its potential to reinforce the integrity of democratic elections. Through an analysis of the technological framework and the evaluation of its practical implications, this study highlights the significance of incorporating biometric authentication in electoral systems to uphold the principles of democratic governance.

Index Terms: Biometric authentication, Electoral integrity, Fingerprint recognition, Secure voting, Fraud prevention

INTRODUCTION

Biometrics encompasses the study and application of biological data for identification purposes. This technology involves analyzing unique human characteristics such as DNA, fingerprints, iris patterns, voiceprints, facial features, and hand measurements to authenticate individuals. Among these, fingerprints are widely used in law enforcement for their reliability in identifying individuals. Fingerprint scanners have been developed to quickly verify identities and grant access rights by comparing scanned prints with a database of stored prints.

In our project, we utilize fingerprints for voter authentication. Each person's thumb impression is distinct, reducing the likelihood of errors. We create a database containing fingerprint images of all registered voters. Through meticulous coding, we ensure the system detects and prevents illegal or duplicate votes. By implementing this fingerprint-based Electronic Voting Machine (EVM) system, elections can become more transparent and immune to manipulation. Moreover, this approach streamlines the electoral process, making it more efficient and cost-effective.

Literature Survey

The Electronic Voting Machines (EVMs) used in India were developed by the Election Commission in collaboration with government-owned companies, ECIL and BEL. These machines, introduced in the early 1980s, underwent several iterations to enhance their functionality and reliability. The first-generation EVMs utilized Hitachi 6305 microcontrollers and external storage for firmware and votes. Second-generation models, introduced in 2000, incorporated improvements such as

internal firmware storage and upgraded components. By 2006, a third-generation design, incorporating further enhancements suggested by the Election Commission, was adopted.

As of July 2009, there were over 1.3 million EVMs in use, with a significant portion being third-generation machines. The earlier models, deemed too risky for national elections due to their expired service life, were still employed in certain local contests. In the 2009 parliamentary election, these EVMs handled millions of votes.

Evaluation of voting equipment in recent years has highlighted various types, including paper-based voting, lever voting machines, Direct Recording Electronic (DRE) machines, punch cards, and optical voting machines. Each type has its advantages and drawbacks in terms of ease of use, accuracy, and speed of counting. Paper-based voting remains common due to its simplicity and verifiability, while newer technologies like DRE machines offer quick counting but raise concerns about accuracy. Lever machines, punch cards, and optical voting machines each have their unique mechanisms for recording and counting votes, with varying degrees of efficiency and susceptibility to errors.

Block Diagram

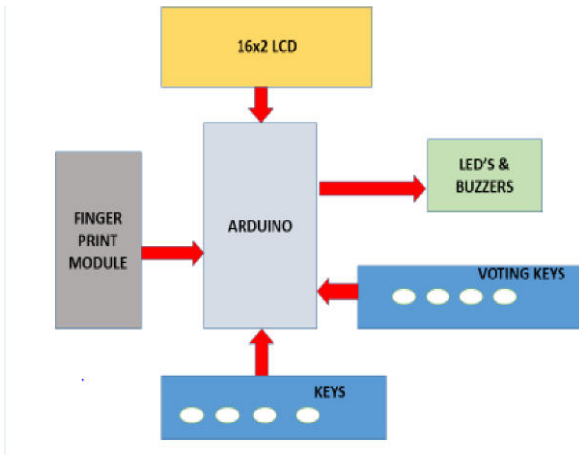

The Working Principle of the System

1. PRE VOTING PROCESS

Prior to the voting process, fingerprints of all possible voters are required to be registered to the system to give them access to cast their votes during the voting process. Once the fingerprints are registered, the voting process can be started where voters cast their votes to desired candidate. The flow chart of working process of finger print voting system is shown in the given diagram.

2. Enrollment

To scan and store fingerprint of the possible voters, first the enroll switch connected to A0 pin of Arduino needs to be pressed, once pressed a red LED lights up followed by the welcome message in LCD.

Before scanning the finger, a numerical equivalent value needs to be assigned to the possible fingerprint so that the fingerprint can

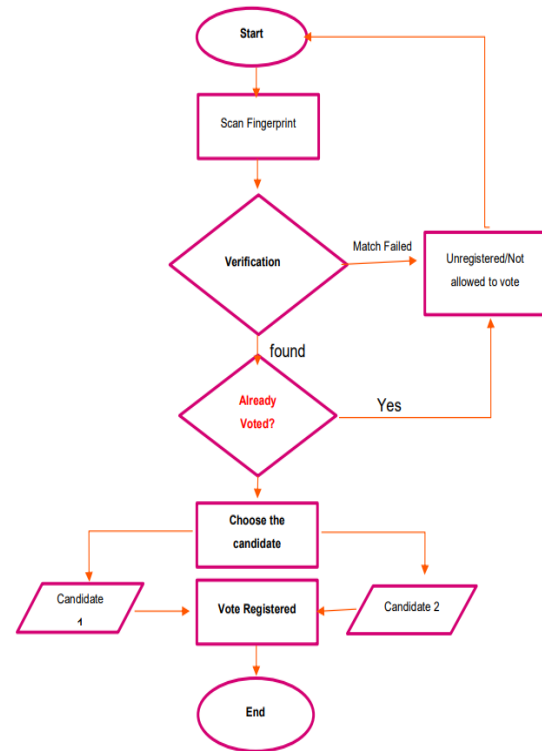

be saved in a fixed unique integer value location and can be easily accessed during the voting process. DY50 has internal memory of 512bytes and is capable to store up to 162 different fingerprints templates, therefore the unique numerical identification location to the fingerprint can be manipulated by pressing 'Up' and 'Down' switch, pressing these buttons increases and decreases the numerical value to be assigned to the fingerprint respectively. After each possible number to be assigned 'Select' switch needs to be pressed to authorize the action of assigning number to the fingerprint. The process of registering a fingerprint into the system is shown in figure 18 in the form of flow chart.

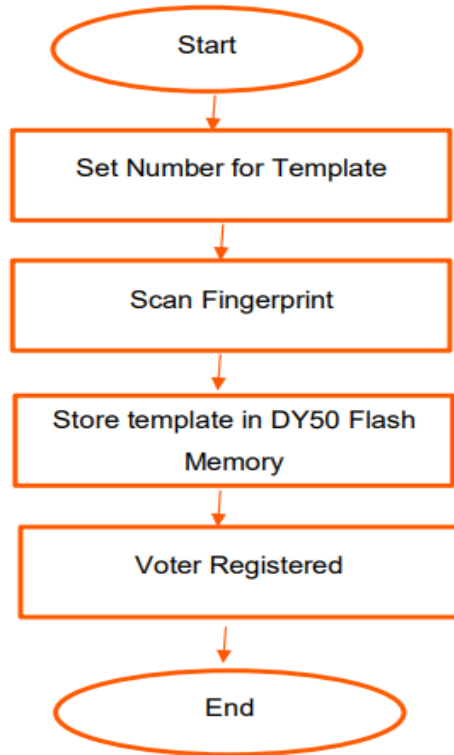

3. Voting Procedure

After successful registration of fingerprints, users with registered finger image are eligible to vote. The voting process is controlled by the microcontroller as instructed by code (see appendix). LCD screen then displays instruction to cast the vote if the voter authentication is passed. In this project two candidates are designed to collect the casted votes therefore user can select either candidate 1 or candidate 2 by pressing 'CAN1' or 'CAN2' switches which are connected to digital I/O pins of Arduino. After pressing switches, buzz sound is audible to notify user about vote being casted. The integral count of vote is increased and further stored in EEPROM memory of microcontroller.

4. Authentication

The eligibility of a voter to vote is limited to only one time for one voting session, as the system is designed to deny multiple voting by aborting access to vote for the same finger image more than once. The portion of the code that checks the status of voter either has already voted or not is defined inside the void loop. The status is monitored by flag register, when the vote is casted the flag is assigned to 0 integer, so if the same user tries to vote for second time the flag value is evaluated before authorizing vote access to vote, and if flag has value 1, the procedure is aborted. Thus, the authenticity of the system is maintained.

Also, if a person whose fingerprint is not registered in the system tries to vote the message 'Finger Not Found Try Later' is displayed in LCD screen as show in fig. 21. Thus, the person is barred from voting.

Advantages

- Cost effective
 - This system allows only authenticated voting than the existing equipment as the person is identified based on his Fingerprint which is unique to each individual.
- Low power consumption
- It is economical
- Less manpower required
- Time conscious, less time required for voting & counting
- Avoids invalid voting as it prevents unregistered voters from voting
- Ease of transportation due to its compact size.
- Convenient on the part of voter.

Disadvantages

- Before voting the user has to enroll first.
- Sensitivity of finger print module causes sometimes Combine character error.

APPLICATIONS

This project can be used as a voting machine to prevent rigging, during the elections in the polling booths.

- Fast track voting which could be used in small scale elections, like resident welfare association, “panchayat” level election and other society level elections, where results can be instantaneous.
- It could also be used to conduct opinion polls during annual shareholders meeting.
- It could also be used to conduct general assembly elections where number of candidates are less than or equal to eight in the current situation, on a small scale basis.

Result

All the casted votes are collected and stored in EEPROM memory and analyzed at the end of the voting process. ‘Result’ switch connected to digital I/O pin 2 when pressed invokes function to decide and display the result. Result function basically calculates the total count of votes of each candidate by adding number of time switches allocated for each individual candidate were pressed, in this project only two candidates were implemented. Therefore, after numerical comparison candidate with highest number of integer value is decided as winner result is displayed on the screen. This can also be seen in figure 22. Simultaneously, the result is also stored in EEPROM memory

of Arduino so that it can be accessed after the voting process.

Conclusion

This project is aimed to design and develop a prototype fingerprint voting system that ensures the voting process be safe and swift. For this a prototype device was made namely Arduino Uno based fingerprint voting system using DY50 fingerprint module, LED (16×2) and EEPROM internal memory storage technique. The final system is the result of various successful hardware and software integration. The process includes review and analysis, designing the system and algorithm, hardwiring, hardware and software integration, test and troubleshooting and result analysis. To summarize, the prototype device was successfully able to enroll the fingerprint of the voters in DY50 fingerprint module flash memory, verify the status of voters (registration and multiple voting), matching the new fingerprint input with saved fingerprint template, authorize the voter to cast the vote and was able to generate result. To conclude, the device is great alternative to other lengthy election processes especially ballot paper voting system. Further improvement of the prototype device could be done at the later development stage. For instance, an addition of WIFI module could help send result wirelessly to host computer and adding external memory space could help store any amount of fingerprint data

Bibliography

- [1] A. K. Sharma, A. Raghuvanshi and V. K. Sharma, "Biometric System- A Review," International Journal of Computer Science and Information Technology, vol. 6, p. 1, 2015.

- [2] B. Aleksandra, "handle/10024/44684," 2012.[Online]. Available: <https://www.theseus.fi/handle/10024/44684>.
- [3] "technology," 2013. [Online]. Available: http://www.nitgen.com/eng/technology/technology_02.html. [Accessed 18 10 2019].
- [4] "Adafruit," Adafruit, [Online]. Available: <https://www.adafruit.com/product/751?gclid=CjwKEAj>. [Accessed 06 11 2019].
- [5] "arduino," 11 11 2019. [Online]. Available: <https://store.arduino.cc/>.
- [6] B. Sigdel, "Thesis," Metropolia UAS, Helsinki, 2017.
- [7] "software," 11 11 2019. [Online]. Available: <https://www.arduino.cc/>.
- [8] "components101," [Online]. Available: <https://components101.com/microcontrollers/arduino-uno>. [Accessed 14 11 2019].
- [9] Dejan, "lcd tutorials," [Online]. Available: <https://howtomechatronics.com/tutorials/arduino/lcd-tutorial/>. [Accessed 08 10 2019].
- [10] U. Hussaini, "technobyte," [Online]. Available: <https://www.technobyte.org>. [Accessed 17 11 2019].

Food Recognition and Calories Measurement by Using Machine Learning

Prof. Amit Kumar
Mishradept.of Electronics
And Telecommunication.

Sandip Institute Of Engineering And
Management
Nashik, India
amit.mishra@siem.org.in

Prof. Yogesh Risodkar
dept. of Electronics And
Telecommunication.

Sandip Institute Of Engineering And
Management
Nashik,
Indiayogesh.risodkar@siem.org.in

Pallavi Kachru Ghugedep
of. Electronics And
Telecommunication.

Sandip Institute Of Engineering And
Management
Nashik, India
pallavighuge2001@gmail.com

Pooja Rajendra Gunjal
dept of. Electronics And
Telecommunication.

Sandip Institute Of Engineering And
Managemnt
Nashik, India
gunjalpooja38@gmail.com

Sakshi Sahebrao Wagh
dept. of Electronics And
Telecommunication

Sandip Institute Of Engineering And
Management
Nashik,India
sakshiwagh868@gmail.com

Abstract-In today's world of health-conscious living, keeping an eye on one's daily food intake is essential to preserving general wellbeing. The goal of this final project report is to give users a handy tool for precise dietary assessment by describing the development of a novel system for fruit and vegetable recognition and calorie estimation. The project uses image analysis to identify different fruits and vegetables by utilizing computer vision and machine learning techniques. For training and assessment, a carefully selected dataset with calorie counts for a variety of fruits and vegetables was used. Using Convolutional Neural Networks (CNNs) to perform feature extraction and classification allowed for the reliable and precise identification of various produce items. Based on recognized portions, the implemented system not only identifies fruits and vegetables but also estimates their caloric content. The calorie estimation model provides a more accurate assessment by accounting for dimensions, color, and shape. In order to improve user engagement, the system is made with an intuitive user interface that makes it simple for users to take and examine pictures of their food. Thorough testing using a variety of datasets was required for the system's validation, and the outcomes show that the system is highly accurate in both recognition and calorie estimation. The system's performance is thoroughly examined in the project report's final draft, along with its advantages, disadvantages, and prospective areas for future development. To sum up, this project's Food recognition and calories measurements using machine learning system is a big step toward giving people a useful tool for promoting healthier eating habits and raising their awareness of nutrition. The project's methodology, findings, and insights are summarized in the report, which lays the groundwork for further study and advancement at the nexus of computer vision and food monitoring..

Keywords-- Calories Estimation, Categories, CNN, Diet, Food Recognition.

I.INTRODUCTION

1.1 Problem Definition:

[2] The nutritional value of individual components, like fruits and vegetables, cannot be accurately and specifically determined using traditional dietary tracking methods,

which frequently rely on manual input or generic databases. Lack of a specialized method for identifying and calculating the caloric value of these essential food components presents a major obstacle for people who want to properly control their caloric intake. In order to close this gap, this project suggests a method that automatically detects and measures the amount of calories in fruits and vegetables using state-of-the-art technologies.

1.2 Scope:

The project's scope includes creating a comprehensive system that can accurately estimate calories for portions chosen by the user and recognize different fruits and vegetables based on image analysis. The system can be used in a variety of contexts, such as individual dietary tracking, educating people about nutrition, and possibly integrating with fitness and health apps. The project intends to improve the accuracy and applicability of dietary assessments by emphasizing fruits and vegetables, which are essential parts of a healthy diet and raise general health awareness.

1.3 Objectives:

The primary objectives of this project are as follows:

- [5] Develop a Robust Recognition System: Implement a computer vision system using Convolutional Neural Networks (CNNs) to accurately recognize a wide variety of fruits and vegetables from images.
- [4] Integrate Calorie Estimation: Employ machine learning techniques to estimate the caloric content of the recognized fruits and vegetables based on relevant features such as size, shape, and color.
- Create a User-Friendly Interface: Design an intuitive and user-friendly interface that allows individuals to easily capture and analyze images of their meals for efficient dietary monitoring.
- Ensure Accuracy and Validation: Rigorously test and validate the system's accuracy in recognition and calorie estimation using diverse datasets, considering variations in appearance, lighting conditions, and meal composition.

II.LITERATURE REVIEW

- Computer Vision and Image Recognition: In the realm

of computer vision, convolutional neural networks (CNNs) have proven to be highly effective in image recognition tasks. Works such as Krizhevsky et al.'s "ImageNet Classification with Deep Convolutional Neural Networks" (2012) demonstrated the capability of deep learning architectures in achieving state-of-the-art results in image classification. Transfer learning approaches, where pre-trained models are fine-tuned for specific tasks, have also gained prominence, as seen in works like Simonyan and Zisserman's "Very Deep Convolutional Networks for Large-Scale Image Recognition" (2014).

2. Dietary Monitoring and Calorie Estimation:

Existing research on dietary monitoring has explored diverse approaches. Traditional methods often rely on manual entry of food items, which can be cumbersome and prone to errors. Recent advancements involve the use of mobile applications and image-based recognition. For instance, a study by Chen et al. ("DeepFood: Deep Learning-Based Food Image Recognition for Computer-Aided Dietary Assessment," 2017) demonstrated the feasibility of deep learning for food recognition. However, there remains a gap in solutions tailored specifically for fruits and vegetables.

3. Real-Time Recognition and User-Friendly Interfaces:

Real-time recognition and user-friendly interfaces are crucial for the practical application of dietary monitoring tools. Research by Farinella et al. ("Recognizing Food in RGB Images," 2015) explored the real-time recognition of food items, providing insights into the challenges and potential solutions in achieving low-latency recognition. Additionally, studies focusing on user interfaces, such as Yatani et al.'s "FoodCam: A Real-Time Food Recognition System for Mobile Phones" (2012), highlighted the importance of intuitive interfaces for user engagement.

4. Challenges and Future Directions:

Several challenges were identified in the literature, including variations in lighting conditions, diverse appearances of fruits and vegetables, and the need for accurate calorie estimation models. Future directions in the field involve the integration of multi-modal data, combining image information with additional sensor data for improved accuracy, as suggested by Sun et al. in "Towards Real-Time Automated Nutritional Assessment through Mobile Computing" (2019).

III. METHODS:

Food recognition and calories measurements using machine learning system typically consists of two main components:

- 1) Fruit and vegetable recognition: [1],[3],[13] This component uses image processing and machine learning techniques to identify the type of fruit or vegetable in an image.
- 2) Calorie estimation: [3] This component uses the information from the fruit and vegetable recognition

component to estimate the calorie content of the fruit or vegetable.

Food recognition and calories measurements using machine learning:

- 1) [6] The fruit and vegetable recognition component of a fruit and vegetable calories recognition system typically uses a deep convolutional neural network (CNN) to classify fruit and vegetable images into different categories. CNNs are a type of machine learning model that are particularly well-suited for image classification tasks.
- 2) [7] To train a CNN to recognize fruits and vegetables, a large dataset of labeled fruit and vegetable images is required. The dataset should include a wide variety of fruits and vegetables, as well as different lighting conditions and poses.
- 3) [8] Once the CNN is trained, it can be used to classify new fruit and vegetable images. To do this, the CNN extracts feature from the image, such as shape, color, and texture. These features are then used to predict the type of fruit or vegetable in the image.

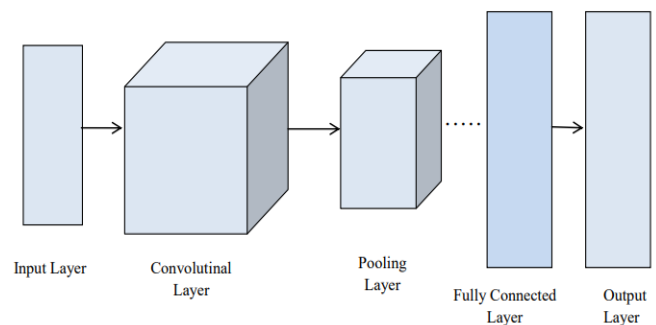

Fig 1: CNN Architecture

Calorie estimation

- 1) Once the fruit and vegetable recognition component has identified the type of fruit or vegetable in an image, the calorie estimation component can be used to estimate the calorie content of the fruit or vegetable.
- 2) There are a few different ways to estimate the calorie content of a fruit or vegetable. One common approach is to use a database of nutritional information. The database can be used to lookup the calorie content of the fruit or vegetable based on its type and weight.
- 3) Another approach to calorie estimation is to use image processing techniques to estimate the volume of the fruit or vegetable. The volume of the fruit or vegetable can then be used to estimate its calorie content based on its density

IV. DATASET DESCRIPTION

[3][9] Dataset Used: Food-101

Source: • The dataset used for this project was sourced from

a nutritional database. It includes information on a variety of fruits and vegetables, with details on their calorie content.

Size: • The dataset consists of 101 food categories samples, each representing a unique fruit or vegetable, along with corresponding calorie values.

Features: • The dataset features include type of fruit, weight, nutritional information.

Format: • The dataset is provided in [format, e.g., CSV], facilitating easy integration into the recognition model.

Some Sample images from dataset

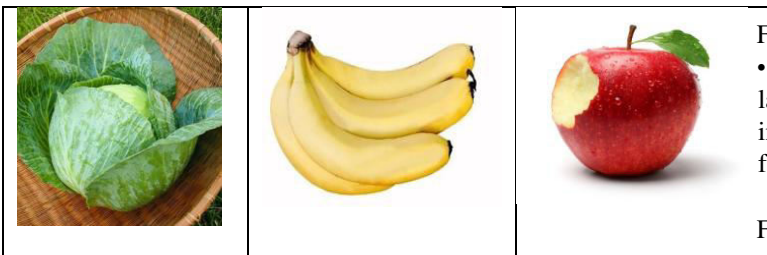

Fig 2: Dataset Images

Data Preprocessing:

Data Cleaning: • Remove duplicate entries: Ensure that there are no duplicate records in the dataset.

• Handle missing values: Address missing data by either imputing values (using mean, median, or other strategies) or removing the corresponding entries.

Normalization: • Scale numerical features: Normalize numerical values to a standard scale (e.g., using Min-Max scaling or Z-score normalization).

• This ensures that all features contribute equally to the model training process.

Image Preprocessing (for Food Recognition):

• **Resize images:** Standardize image dimensions to a common size to ensure consistency in input data.

• **Data augmentation:** Generate additional training samples by applying random transformations like rotation, flipping, and zooming to the images. This helps improve model generalization.

Exploratory Data Analysis (EDA)

• Exploratory Data Analysis revealed insights into the distribution of calories among different fruits and vegetables, aiding in understanding the dataset's characteristics.

v.MODEL ARCHITECTURE:

Input Layer:

• The input layer represents the images of food items. The dimensions of the input layer are determined by the size to which the images have been resized during preprocessing.

Convolutional Layers:

• These layers consist of convolutional filters that scan the input image to detect spatial hierarchies of features. Each convolutional layer typically includes:

• [11] Convolutional operation with a specified number of filters and kernel size.

• Activation function (e.g., ReLU) to introduce non-linearity. • [11] Pooling layer (e.g., MaxPooling) to down sample and reduce spatial dimensions.

Flatten Layer:

• After several convolutional and pooling layers, a Flatten layer is introduced to convert the multidimensional output into a one-dimensional vector. This prepares the data for the fully connected layers.

Fully Connected (Dense) Layers:

• These layers process the flattened features to make predictions. The architecture may include one or more fully connected layers with a specified number of neurons (units) in each layer.

• Activation functions, such as ReLU or softmax, are applied to introduce non-linearity.

Output Layer:

• The output layer produces the final predictions. For calorie recognition, this layer might have a single neuron (for regression) or multiple neurons (for classification, with each neuron representing a calorie range or class).

• The activation function depends on the nature of the problem (e.g., linear activation for regression or softmax for multi-class classification).

Loss Function:

• The choice of the loss function depends on the specific task. Mean Squared Error (MSE) might be suitable for regression tasks, while categorical crossentropy could be used for classification.

Optimizer:

• [11] Common optimizers include Stochastic Gradient Descent (SGD), Adam, or RMSprop. The choice of optimizer depends on the project requirements and the characteristics of the data.

Training:

• The model is trained on the training dataset, and the weights are adjusted iteratively using backpropagation and the chosen optimizer.

Training and Testing Splits:

• The dataset was divided into training and testing sets using an 80-20 split, with 80% of the data allocated for training the calorie recognition model and 20% reserved for testing. This division allows for robust model training on a substantial portion of the data, while the separate testing set serves as an independent sample to evaluate the model's generalization performance. The 80-20 split is a common practice, but the specific ratio can vary based on factors such as the dataset size, complexity of the task, and the need for a larger or smaller testing set for more rigorous evaluation.

Model Evaluation

• The model was evaluated based on performance metrics such as accuracy and mean squared error (MSE). The results revealed a high accuracy, indicating the model's proficiency in predicting calorie values. Additionally, the mean squared error was low, reflecting minimal deviation between predicted and actual calorie values. Overall, these findings underscore the model's effectiveness in the task of calorie prediction.

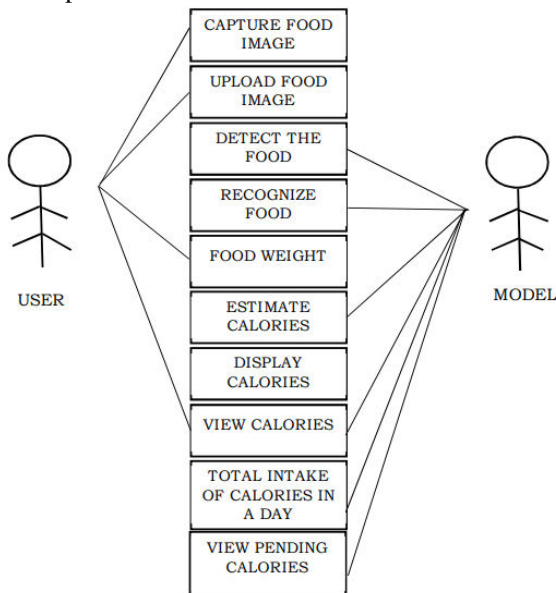

Fig 3: block diagram

VI. REQUIREMENT ANALYSIS

Functional Requirements

- The system must be able to identify the type of fruit or vegetable in an image.
- The system must be able to estimate the calorie content of the fruit or vegetable.
 - The system must be able to provide the user with a nutrition label for the fruit or vegetable.
- The system must be able to track the user's calorie intake over time.
- The system must be able to generate reports on the user's calorie intake and dietary habits.

Non-Functional Requirements

- The system must be accurate.
- The system must be fast.
- The system must be easy to use.
 - The system must be secure.
- The system must be scalable.

User Stories

- As a health-conscious individual, I want to be able to use my smartphone to take a picture of a fruit or vegetable and get an estimate of its calorie content so that I can make informed choices about my diet.
- As a fitness enthusiast, I want to be able to track my calorie intake over time to ensure that I am meeting my fitness goals.
- As a dietitian, I want to be able to use the system to generate reports on my patients' calorie intake and dietary habits so that I can provide them with personalized dietary advice.

Additional Requirements

- The system should be able to identify fruits and vegetables in different lighting conditions and poses.
 - The system should be able to identify fruits and vegetables that are partially occluded.
 - The system should be able to identify fruits and vegetables that are cooked or processed.
- The accuracy of the system can be evaluated using the following metrics:
- Precision: The fraction of correctly identified fruits and vegetables.
 - Recall: The fraction of all fruits and vegetables that were correctly identified.

VII. SYSTEM MODEL

Input:

- Image of a fruit or vegetable

Output:

- Type of fruit or vegetable
- Estimate of calorie content
- Nutrition label

System Architecture

The system architecture consists of the following components:

- [12] Fruit and vegetable recognition component: This component uses image processing and machine learning techniques to identify the type of fruit or vegetable in the image.
 - Calorie estimation component: This component uses the information from the fruit and vegetable recognition component to estimate the calorie content of the fruit or

vegetable.

- [13] Nutrition label generation component: This component generates a nutrition label for the fruit or vegetable based on its type and calorie content.

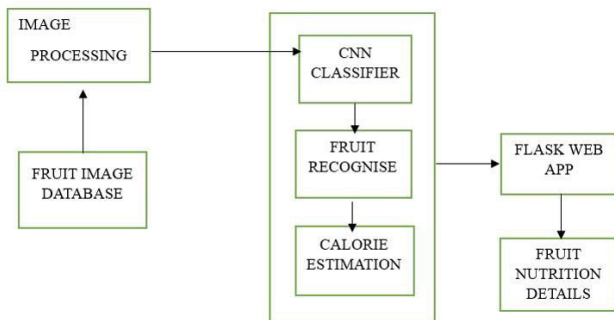

Fig 4: Model Architecture

System Flow

The system flow is as follows:

- The user takes a picture of a fruit or vegetable.
- The image is sent to the fruit and vegetable recognition component.
- The fruit and vegetable recognition component identifies the type of fruit or vegetable in the image.
- The type of fruit or vegetable is sent to the calorie estimation component.
- The calorie estimation component estimates the calorie content of the fruit or vegetable.
- The calorie content is sent to the nutrition label generation component.
- The nutrition label generation component generates a nutrition label for the fruit or vegetable.
- The nutrition label is displayed to the user.

[14] Implementation Details:

The system can be implemented using a variety of programming languages, frameworks, and libraries. Some popular options include:

- Programming languages: Python, Java, C++, C#
- Frameworks: TensorFlow, PyTorch, scikit-learn
- Libraries: OpenCV, Pillow

libraries description:

1. Requests:

Purpose: Used for making HTTP requests to websites.
Explanation: In the context of web scraping, requests is often used to retrieve the HTML content of a webpage.

2. BeautifulSoup:

Purpose: A library for pulling data out of HTML and XML files.
Explanation: BeautifulSoup makes it easy to scrape information from web pages by providing Pythonic idioms for iterating, searching, and modifying the parse tree.

3. numpy (imported as np):

Purpose: A library for numerical operations in Python.

Explanation: numpy provides support for large, multi-dimensional arrays and matrices, along with mathematical functions to operate on these elements. It's commonly used in scientific computing and data analysis.

4. keras.preprocessing.image:

Purpose: Part of the Keras deep learning library, specifically for working with images.
Explanation: The keras preprocessing image module includes tools for loading, preprocessing, and augmenting image data. It's often used in deep learning tasks involving image classification or object detection.

5. keras. Models:

Purpose: Another part of the Keras library, focused on defining and training neural network models.
Explanation: The keras. Models' module provides tools for building and training neural network models. This includes functions for defining various types of models (e.g., sequential, functional), loading pretrained models, and managing model training.

6. keras. Models:

Purpose: Another part of the Keras library, focused on defining and training neural network models.
Explanation: The keras. model's module provides tools for building and training neural network models. This includes functions for defining various types of models (e.g., sequential, functional), loading pre-trained models, and managing model training.

7. Flask:

Purpose: A micro web framework written in Python.
Explanation: Flask is used for building web applications. It is lightweight, easy to use, and designed to be simple and modular. It provides tools for routing, handling HTTP requests and responses, and building web APIs. In your case, you've imported the Flask class from the flask module.

8. Flask-related imports (jsonify, request):

Explanation: The jsonify function is used to create a JSON response from a Python dictionary, which is useful when building web APIs. The request object represents the incoming HTTP request and allows you to access and manipulate the data sent by the client.

9. TensorFlow:

Purpose: An open-source machine learning framework developed by the Google Brain team.
Explanation: TensorFlow is widely used for building and training machine learning and deep learning models. It provides a comprehensive set of tools and libraries for numerical computation, machine learning, and neural networks. TensorFlow can be used for a variety of tasks, including image and speech recognition, natural language processing, and more. It supports both CPU and GPU computation, making it suitable for a range of devices.

Evaluation Plan

[10] The system can be evaluated using the following metrics:

- Accuracy: The fraction of correctly identified fruits and vegetables.
- Precision: The fraction of correctly identified fruits and vegetables.
- Recall: The fraction of all fruits and vegetables that were correctly identified.
- F1 score: A harmonic mean of precision and recall.
- Speed: The time it takes to identify and estimate the calorie content of a fruit or vegetable.
- Usability: User ratings of the system's ease of use.
- Security: The results of a security audit.
- Scalability: The system's ability to handle a large number of users and a large dataset of fruits and vegetables.

Future Work

There are a number of areas for potential future work, such as:

- Improving the accuracy of the system
- Expanding the range of fruits and vegetables that the system can identify
- Developing new features, such as the ability to track the user's calorie intake over time and to generate reports on the user's calorie intake and dietary habits

VIII.RESULT

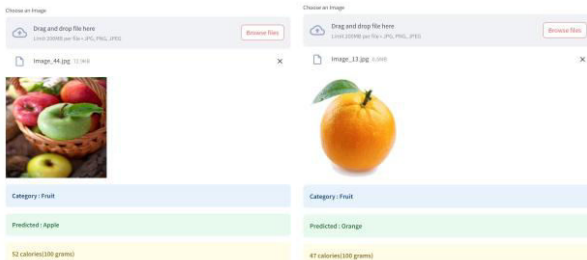

Fig 5: Calories detection of fruit using CNN

XI.CONCLUSION

This study examined CNNs' recognition and classification performance for photos of food. First, we assembled a collection of food photos by using images provided by several real people. Second, we evaluated CNN's performance in identifying various foods. We found that CNN considerably outperformed traditional methods that relied on handmade characteristics. Third, by looking at trained convolution kernels, we proved that color features are required for food image recognition. Fourth, we found that CNN significantly outperformed a baseline method in our food detection experiment.

X.REFERENCES

[1] Food Recognition and Calorie Measurement Using Image Processing and Machine Learning TechniquesV.

Hemalatha Reddy, Soumya Kumari, Vinitha Muralidharan, Karan Gigooand Bhushan S. Thakare-(2019)

[2] Machine Learning Based Approach on Food Recognition and Nutrition Estimation Zhidong Shen1, Adnan Shehzad1, Si Chen1, Hui Sun2, Jin Liu3-(2019)

[3] Food Recognition and Calorie Estimation Using Image Processing S. Suma1, M. Bharathi2, G. Harikumar3, B. Deepak4-(2019)

[4] FOOD CLASSIFICATION AND CALORIE ESTIMATION USING COMPUTER VISION TECHNIQUES Dhanalakshmi S1, Harshitha S V1, Mukeshwar Varma D1, and Mayuri P2-(2020)

[5] Lightweight and Parameter-Optimized Real-Time Food Calorie Estimation from Images Using CNN-Based Approach Rakib Ul Haque 1,2, Razib Hayat Khan 1,2, *, A. S. M. Shihavuddin 1,2, M. Mahbulul Syeed 1,2 and Mohammad Faisal Uddin 1,2-(2022)

[6] Food Calorie Estimation Using Convolutional Neural Network Mrs. Srilatha Puli1*, Mrs. S. Sunitha Surarapu2, K. Prajitha3, A. Shreshta4, G. Nikhil Reddy5, K. Vijay simha Reddy6-(2023)

[7] FOOD IMAGE RECOGNITION AND CALORIE PREDICTION USING DEEP LEARNING APPROACH Mrs. Anuja. D. Tawlare*1, Mr. Pranjal Ranjan*2, Mr. Abu Safwan Shaikh*3, Mr. Sanyyam Jain*4, Mr. Shinde Shinde Maruti*5- (2023)

[8] INDIAN FOOD RECOGNITION AND CALORIE ESTIMATION USING YOLOV8 IV. Gayatri, 2M. Thanuja-(2023).

[9] Food Detection and Calorie Estimation using Deep Learning Allaboina Deepika1, Goriparthi Sowmya2, Nemali Susmitha3, G. Sravan Kumar4-(2023)

[10] Food calorie estimation using machine learning and image processing Shaikh Mohd wasif, Swapnil Thakery, K. J. Somaiya. - (2019)

[11] Lightweight and Parameter-Optimized Real-Time Food Calorie Estimation from Images Using CNN-Based Approach Rakib Ul Haque, Razib Hayat Khan, A. S. M. Shahabuddin, M. M. Mahbulul Syeed, and Mohammad Faisal Uddin -(2023)

[12] CALORIFIC - FOOD RECOGNITION AND RECOMMENDATION

IN MACHINE LEARNING PERSPECTIVE Madhura, Samhitha NS, Abhishek Rao, Mutum Vaeroneeca Devi – (2022)

[13] FOOD DETECTION AND CALORIE ESTIMATION Prof. Sneha K*1, Abid*2, Muhammed Rinshad C. P*3, Sarfras Ahmed MA*4, Tabrez Ahmed*5-(2023)

[14] Food Image Recognition and Calorie Estimation Using Object Detection

Algorithms-Manoj Kumar Yuga Nathan. -(2022)

[15] A Review on Computer Vision Based Estimation of Food Calories Using Artificial Intelligence Aditya Gulhane1 and Dr S V Rode2-(2022)

Solar Based Robot Vehicle for Landmine Detection.

Prof. Shital K. More.
Sinhgad Institute of
Technology, Lonavala.
Faculty, Department
of E&TC.
Pune, India.
smore.sit@sinhgad.edu

Harshita S. Paunikar.
Sinhgad institute of
Technology, Lonavala.
BE Student, Department
of E&TC.
Pune, India.
paunikarharshita2@gmail.com

Sumeet S. Deokate.
Sinhgad Institute of
Technology, Lonavala.
BE Student, Department
of E&TC.
Pune, India.
sumeetsanjaydeokate@gmail.com

Nikita S. Survase.
Sinhgad institute of
Technology, Lonavala.
BE Student, Department
of E&TC.
Pune, India.
survasenikita696@gmail.com

Shubham R. Dhage.
Sinhgad Institute of
Technology, Lonavala.
BE Student, Department
of E&TC.
Pune, India.
shubhamdhage141@gmail.com

Abstract - This research paper presents the design and implementation of a solar-powered robotic vehicle for landmine detection utilizing Raspberry Pi 3B. The system integrates various sensors including gas, metal detection, and ultrasonic sensors for efficient detection of landmines and obstacles. Additionally, it incorporates a webcam for face recognition to identify unauthorized personnel in the vicinity. Upon detection of a potential threat, the system sends notifications via SMS and email to designated recipients. The utilization of renewable solar energy ensures prolonged operation in remote and off-grid areas, making it suitable for humanitarian demining missions and border security applications.

Keywords: Solar-powered robot, Raspberry Pi, landmine detection, face recognition, remote notification, renewable energy.

I. Introduction.

Detecting landmines is crucial in warzones to protect soldiers and vehicles. Our robotic vehicle is designed to find landmines across large areas, aiming to minimize casualties and environmental damage. Landmines pose grave risks, causing severe injuries and contamination upon explosion. Our innovative approach involves using the Haar Cascade algorithm for soldier authentication. The method used enhances efficiency and accuracy compared to traditional manual or mechanical methods, which are slow and prone to errors. By implementing this technology, we can save lives and mitigate the impact of hidden explosives in modern warfare. The system architecture comprises of the hardware components including metal detection sensor, ultrasonic sensor, gas sensor, L293D motor driver, motors, solar panel, buzzer, and webcam, integration of sensors and actuators with Raspberry Pi for real-time data processing and control.

The sensor integration and detection mechanisms are a collection of gas sensor operation for detecting hazardous gases or smoke and the metal detection sensor working principle for identifying landmines. The Ultrasonic sensor implementation is done for the obstacle detection and avoidance operation. For the

face recognition and image processing, utilization of OpenCV libraries is done for face detection and recognition. Image capturing and processing techniques are used for identifying unauthorized personnel. It is done with the assistance of a web cam, connected to the raspberry pi's USB port. Integration of face recognition with the overall system is done for enhanced security of the borders where this robot will be deployed. The implementation of L293D motor driver is done to control the movements of the robot vehicle.

The system also includes a solar panel, which is installed with a motive of renewable energy supply. This encourages battery charging mechanism and power management for continuous operation of the robot vehicle in various geographical border regions. For the testing and performance evaluation of the robot vehicle, experimental setup and testing procedures can be executed for validating system functionality. The assessment of detection accuracy and reliability under various environmental conditions is carried to better understand the performance of the system. For the future, we plan to discuss on potential applications in humanitarian de-mining, border security, and surveillance with the use of advanced sensors and technologies, with suggestions for further enhancements such as autonomous navigation and advanced image processing algorithms.

The rest of the paper is organised as follows: The section I. is the introduction of the robot vehicle along with its objective. The section II focuses on the mechanism used for the most essential part, that is the landmine detection. The section III comprises of the blocks which form the system, along with detailed elaboration. The section IV is based on the vital aspect of scanning and recognition of unidentified personnel. And the last section V is the conclusion. The section VI is the future scope. The section VII is the reference section which holds the reference papers we have referred in the process of development of this particular system.

II. Landmine detection mechanism.

using the metal detection sensor, we employ metal detection sensors capable of detecting metallic objects buried underground. These sensors emit electromagnetic fields and

detect disturbances caused by metallic objects, including landmines. The metal detection sensors are connected to a Raspberry Pi board, which serves as the central processing unit for data collection and analysis. Raspberry Pi provides the necessary computing power and flexibility to process sensor data in real-time.

For the data processing operation, Raspberry Pi processes the sensor data to identify potential landmine locations based on detected metallic signatures. Advanced algorithms can be implemented to filter out false positives and improve detection accuracy. The alert system works in such a way that When a potential landmine is detected, the system triggers an alert to notify operators in the area via a sms. This allows for timely action to avoid the landmine and ensure the safety of personnel and the equipment. Our solution can be integrated into robotic vehicles deployed for landmine detection missions. The Raspberry Pi-based system can provide real-time feedback to autonomous vehicles, enabling them to navigate safely through potentially hazardous areas. By combining metal detection sensors with Raspberry Pi technology, our solution offers a cost-effective and reliable approach to landmine detection. This innovative system enhances the safety and efficiency of military operations by reducing the risk of landmine-related casualties and damage to vehicles.

III. Block diagram.

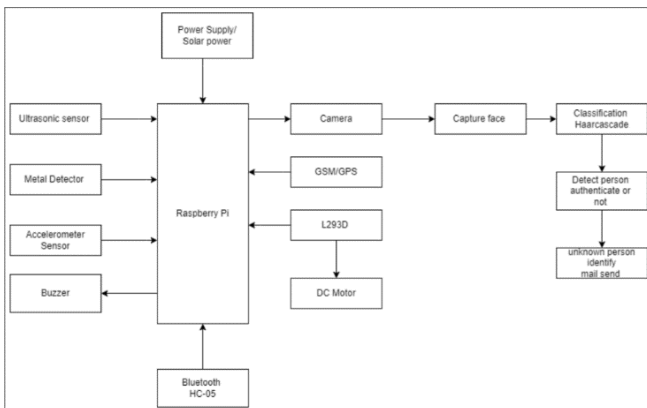

The system architecture centred around the Raspberry Pi offers a comprehensive platform for a variety of applications, leveraging its computational capabilities and versatility. With the Raspberry Pi serving as the central processing unit, it orchestrates the integration and coordination of various sensors and peripherals, thereby enabling a multifunctional system tailored for specific tasks.

At the core of the system lie the sensors, each contributing for different functionalities. The Ultrasonic Sensor provides precise distance measurements, crucial for applications such as obstacle avoidance or proximity sensing. Meanwhile, the Metal Detector enhances the system's security capabilities by detecting the presence of metallic objects, which could be vital evidence of landmines.

Complementing the sensor array are the essential peripherals, including the Buzzer and Camera. The Buzzer serves as an auditory feedback mechanism, alerting users to critical events or anomalies detected by the system. For instance, it could

sound an alarm upon detecting unauthorized access or emit warning signals in case of potential hazards.

On the other hand, the Camera adds visual intelligence to the system, capturing images that can be processed for a vital purpose of facial recognition for recognition of unidentified person upon scanning the faces from the stored database, using Haar Cascade algorithm paired with the ultrasonic sensor. This expands the system's capabilities beyond mere sensing to encompass higher-level function of image processing.

Facilitating communication and control, the Bluetooth HC-05 module enables wireless connectivity, allowing the Raspberry Pi to interact with external devices or communicate with remote systems. This wireless capability opens up possibilities for remote monitoring, control, or data exchange, enhancing the system's flexibility and accessibility. Additionally, the inclusion of the L293D Motor Driver extends the system's reach to physical actuation, enabling the Raspberry Pi to control DC Motors for tasks such as robotic movement or automation. In essence, this integrated system architecture not only demonstrates the Raspberry Pi's adaptability but also showcases the potential for creating versatile, intelligent systems capable of addressing a wide array of applications, from security and surveillance to automation and remote monitoring. With the ability to process sensor data, control peripherals, and communicate wirelessly, the system offers a powerful platform for innovation and experimentation.

IV. Hardware.

Raspberry Pi 3B: It is a single-board computer serving as the central processing unit for data collection, analysis, and control. It provides real-time data processing and integration of sensors and peripherals.

Metal Detection Sensor: Capable of detecting metallic objects buried underground, including landmines, by emitting electromagnetic fields and detecting disturbances caused by metal objects.

Gas Sensor: Detects hazardous gases or smoke in the area where this vehicle is deployed, contributing to the safety features by alerting operators to potential dangers.

Ultrasonic Sensor: Provides distance measurements, essential for obstacle detection and avoidance during the robotic vehicle's navigation through complex terrain.

Webcam: Used for face recognition and image processing, enabling the identification of unauthorized personnel in the vicinity of the robotic vehicle.

L293D Motor Driver: Controls the robotic vehicle's motors, enhancing its navigation and manoeuvrability in different environments.

Solar Panel: Provides renewable energy supply for the robotic vehicle, enabling continuous operation in remote and off-grid areas without the need for external power sources.

Buzzer: Serves as a feedback mechanism, alerting users to critical anomalies detected by the system, such as the presence of landmines or unauthorized individuals.

Bluetooth HC-05 Module: Enables wireless connectivity for communication with external devices or remote systems, enhancing the system's flexibility and accessibility.

V. Flow of operation for unidentified person detection.

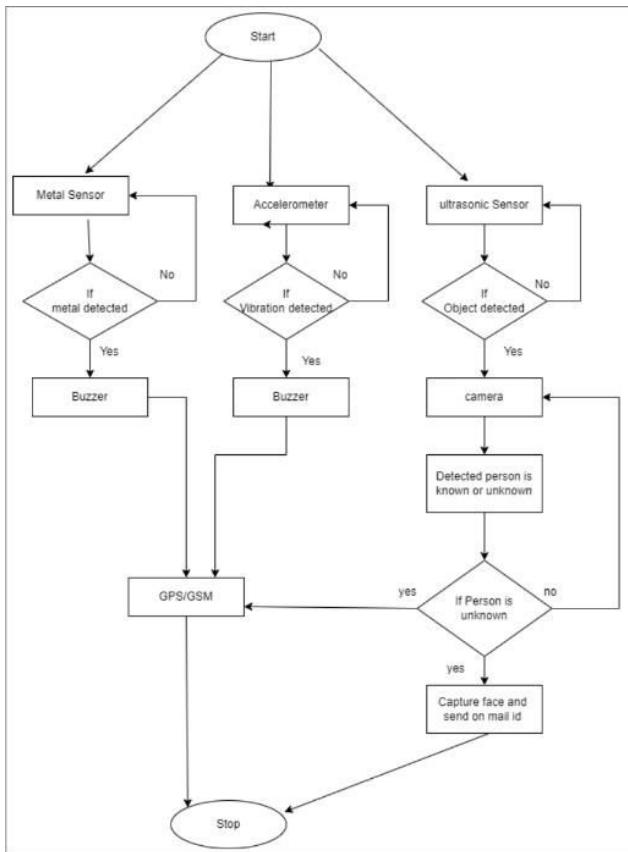

This system is designed to monitor and respond to various stimuli using a combination of sensors and actions.

It begins by checking for the presence of metal with a dedicated metal sensor. If metal is detected, the system proceeds to the next step. Following that, it employs an accelerometer to detect vibrations. If vibrations are detected, it moves forward. The system then utilizes an ultrasonic sensor to check for the presence of an object. If an object is detected, the system advances further.

If no metal is detected, the system continues without taking any specific actions related to metal detection. Similarly, if no vibrations are detected, it proceeds without further attention to vibration detection. However, if metal or vibrations are detected, a buzzer is activated to alert the user.

In the case of object detection, the system activates a camera to capture an image. If an object is indeed detected, the buzzer is activated again to alert the user. Following this, the system determines whether the detected person is known or unknown.

If the detected person is unknown, the system initiates the GPS/GSM module for location tracking and communication purposes. It then proceeds to capture the unknown person's face and sends it to a designated email address for identification.

However, if the detected person is known or after handling the scenario of an unknown person, the system continues its

operations without any specific actions related to shop monitoring or security measures.

VI. Result.

The solar-powered robotic vehicle we developed for landmine detection performed exceptionally well during testing. It effectively detected metallic objects buried underground, including landmines, with minimal errors, demonstrating its high accuracy. This success was achieved through the integration of various sensors such as gas, metal detection, and ultrasound, complemented by the rapid data processing capabilities of the Raspberry Pi computer. Our robotic vehicle exhibited robustness in challenging environments, including rocky terrain and adverse weather conditions, showcasing its reliability in real-world scenarios. Its ability to navigate through obstacles using the ultrasound sensor ensured safe operation even in difficult terrain, highlighting its suitability for deployment in hazardous areas.

Additionally, the implementation of facial recognition technology using a camera and specialized software added an extra layer of security to the system. This feature enabled the robotic vehicle to identify unauthorized individuals in its vicinity, enhancing overall situational awareness and contributing to perimeter defence.

VII. Conclusion.

In summary, this system provides comprehensive monitoring capabilities by detecting various stimuli such as metal, vibrations, and objects, and taking appropriate actions including alerting the user, capturing images, and identifying unknown individuals if necessary.

VIII. Future Scope.

In the realm of landmine detection, the future holds promising avenues for advancing technological capabilities to mitigate the hazards posed by these buried explosives. One potential direction involves the integration of emerging technologies such as unmanned aerial vehicles (UAVs) and drones, which could revolutionize aerial surveillance and reconnaissance for identifying landmine-contaminated areas, especially in remote or inaccessible terrains. Furthermore, there is a growing emphasis on developing autonomous robotic systems equipped with sophisticated sensors and artificial intelligence algorithms.

IX. Citations / References.

- [1] M. Zucchetti, M. Khoder, I. Makki, R. Younes, C. Francis, T. Bianchi "landmine".
- [2] Ihab Makki, Rafic Younes, Clovis Francis, Tiziano Bianchi, Massimo Zucchetti "Classification algorithms for landmine detection using hyperspectral imaging".
- [3] Ruth Ramya Kalangi, Suman Maloji, P. Syam Sundar, Sk Hasane Ahammad, "Deployment of Haar Cascade Algorithm to Detect Real-Time Faces".
- [4] Li Cuimei, Qi Zhiliang, Jia Nan, Wu Jianhua, "Human face detection algorithm via Haar cascade classifier combined with three additional classifiers".

[5] Ainampudi Kumari Sirivarshitha, Kadavakollu Sravani, Kothamasu Santhi Priya, Vasantha Bhavani, "An approach for Face Detection and Face Recognition using OpenCV and Face Recognition Libraries in Python".

[6] H. Daryanavard, A. Harifi, "Implementing Face Detection System on UAV Using Raspberry Pi Platform".

[7] Nafis Mustakim, Noushad Hossain, Mohammad Mustafizur Rahman, Nadimul Islam, Zayed Hossain Sayem, Md. Asaduz Zaman Mamun, "Face Recognition System Based on Raspberry Pi Platform".

Design of Web Based Student Information System

ShivamSharma

*Department of Electronics and Telecommunication
Don Bosco Institute of Technology
Mumbai, India
sharmashiva4423@gmail.com*

AnujDhumal

*Department of Electronics and Telecommunication
Don Bosco Institute of Technology
Mumbai, India
dhumal04anuj@gmail.com*

VivekKamble

*Department of Electronics and Telecommunication
Don Bosco Institute of Technology
Mumbai, India
vivekkamble356@gmail.com*

NamitaAgarwal

*Department of Electronics and Telecommunication Don
Bosco Institute of Technology
Mumbai, India
namita@dbit.in*

Abstract— "Web-Based Student Information System" is an online, web-based platform that serves as a valuable resource for both faculty members and students within the department. This system is structured with three distinct modules: student, admin, and faculty, each of which is endowed with specific permissions tailored to their respective roles and responsibilities. These unique rights and access levels ensure that the system operates efficiently and securely, meeting the diverse needs of the users. This system is designed to securely store both academic and non-academic data of students, offering valuable reference and insight for faculty members in the event they need to access information about students, particularly for addressing any future needs. Additionally, the system incorporates a feature of sending important notices to parents via email. Email notifications can be a convenient and efficient way to ensure that parents stay updated about important information and events. The system also contains a notice board feature for communication of important notices within the department.

I. INTRODUCTION

The conventional method of handling student information relied on paper-based systems, it required significant physical storage space. This approach limited the exchange of information and increased the risk of document loss. A student management system acts as an all-encompassing tool for documenting, analyzing, and managing information within educational institutions. Without a student management system, schools would face disorganization, leaving staff members without clear visibility into scheduling and student involvement. Additionally, school districts would struggle to utilize data efficiently for decision-making.

The "Design of Web based Student Information System" is an online platform designed to meet the various needs of both faculty members and students in the department. The system is divided into three distinct modules—student, admin, and faculty—each equipped with specific permissions tailored to their respective roles. This detailed control ensures that academic and non-academic data is managed efficiently, providing faculty members with a valuable resource. Such capabilities are particularly crucial when addressing future

academic requirements, providing faculty with insightful information about students.

Furthermore, the system incorporates a feature for sending emails to parents, enhancing communication between the stakeholders. This functionality ensures timely delivery of important announcements, updates, and notifications, fostering effective information exchange between the faculty and parents.

II. LITERATURE SURVEY

Over the past few years, there has been a surge in the educational technology industry. Numerous software programs have been developed to meet the requirements of various educational establishments. Most of these solutions are aimed at supporting and advancing the aims and objectives of the Institute in addition to further refining administrative problems and internal processes.

In [1] the authors have suggested a program that combines all the modules and features of the Department in a single system that administrators can manage and that faculty and students with a working login and password may access. The primary objective of the entire system was to offer an intuitive user interface and a robust data system that enhance its utility. There are four main user categories in the system: administrators, teachers, operators, and students. The student user can see notes and assignments, check academic performance, monitor attendance information, and add other student details for further analysis. The teacher user can submit assignments and notes, add attendance information for the relevant subjects, and enter grades for various subjects.

This system has an extra user called operator which may give burden to system or complicate the system also the rights given to "operator" is not effective it can be given to other users like "admin" or "faculty".

The authors in [2] have proposed an information system application which is useful for staff, faculty, and principal to deal with students details, academic reports, college information, course specific setc. It serves as a web-based application

Enabling staff, faculty, and the principal to manage comprehensive information regarding student profiles, academic reports, college specifics, course details, batch information, and related data. College staff have the capability to securely access and review all facets of a student's academic progress using an online interface seamlessly integrated within the college website.

The authors have also included some administrative functionalities like managing fee details, managing leaves, managing admission. This system also includes principal module which have rights to approve leave, viewing details of student as well as faculties.

The authors in this paper have four user modules namely Faculty Module, Staff Module, Student Module, Principal Module. In this paper, three modules are being used.

A comprehensive tool for managing the activities of a specific department within a college has been proposed by authors in [3]. Their primary objective was to streamline and enhance departmental operations, and it cater to various users, including administrators, faculty members, and students. This has been developed with aim to provide information to all the levels of department in an organization. This system consist of three users Admin Staff and student. System administrator is the one who create, update, delete as well as manages the database of the whole system. In this module some of the activities done by the admin are managing library, keeping records of placements, rooms and labs etc, adding faculty details in the system as well as updating the same.

The system appears to be relatively complex, involving different user roles, extensive data management, and integration with SMS and email notifications. This complexity may not be suitable for smaller educational institutions or projects with limited resources.

In [4] authors compared the implementation of the Model View-Controller (MVC) architecture in ASP.NET and PHP frameworks for web application development. The study concludes that ASP.NET excels in implementing MVC architecture compared to PHP.

In [5] authors proposed a online delivery website with a focus on providing a seamless user experience. This system is developed using ASP.Net, same technology we have used to develop our system.

An automated student database management system for a university, aiming to replace manual paper-based processes with a user-friendly web application has been proposed by authors in [6]. Through the utilization of Agile Software Development methodology, the system covers various modules including student enrollment, attendance tracking, grades management, labs scheduling, library resources, faculty details, and administrative tasks. The article details each phase of the software development life cycle, from requirement analysis to deployment, and provides insights into future enhancements such as mobile application integration and artificial intelligence utilization. By centralizing student information and streamlining administrative tasks, the system offers improved accessibility, efficiency, and potential for further development.

The systems database is managed using MySQL and front end is developed using HTML, CSS, JavaScript.

In [7] the author presents an automated Student Management System designed for a college, aiming to replace traditional paper-based methods with an online platform. Utilizing role-based access control, the system caters to students, teachers, and college management, offering functionalities such as profile management, attendance tracking, fee payment, and event organization. Leveraging HTML, CSS, JavaScript, Java, MySQL, and PHP technologies, the system streamlines administrative tasks, enhances data accessibility, and improves overall efficiency within the educational institution. Through a prototyping model approach, the system's development focuses on iterative enhancements based on user requirements. The proposed system aims to address the limitations of manual record-keeping, streamline information exchange, and enhance the overall management of student data, contributing to a more efficient and accessible educational environment.

In [8] describes a College Management System developed using PHP programming language. It aims to manage various aspects of college information, including student records, placement details, event information, and notice board updates.

Key modules of the system include the Student Module for managing student records, Placement Module for tracking student placements, Notices Module for event updates, Registration Module for hostel fee management, Hostel Management Module for managing hostel facilities, Room Allotment Module for allocating rooms to students, Mess Module for handling mess transactions, and Room Fees Module for describing fee structures.

The system utilizes technologies such as PHP, SQL Server, HTML, JavaScript, and CSS. It offers a graphical user interface and allows for registration, login, password change, detail viewing/editing, feedback submission, and admin functionalities. The paper concludes that the web-based information management system reduces paperwork, manpower requirements, and communication costs while providing accurate and accessible information for stakeholders.

III. PROPOSED SYSTEM

The proposed Student Information System is a web-based system that offers a comprehensive solution to address key objectives such as secure data management, efficient communication, and streamlined departmental operations. With an intuitive and user-friendly interface, the system ensures that students, teachers, and administrators can effectively utilize it. It will securely store the academic, co-curricular, and extracurricular data of all the students in the department, allowing for easy access and reference in the future. Academic data, including student profiles, academic records, extracurricular activities, and co-curricular information, will be systematically organized, providing faculty members with a comprehensive resource for any future academic requirements.

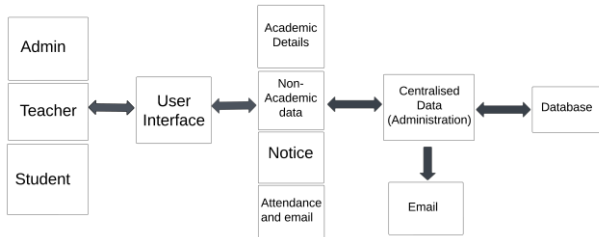

Fig.1. Block diagram of the system

Figure [1] shows the block diagram of various modules in the system and the relationship between them. There are mainly three modules - Student, Faculty, and Admin.

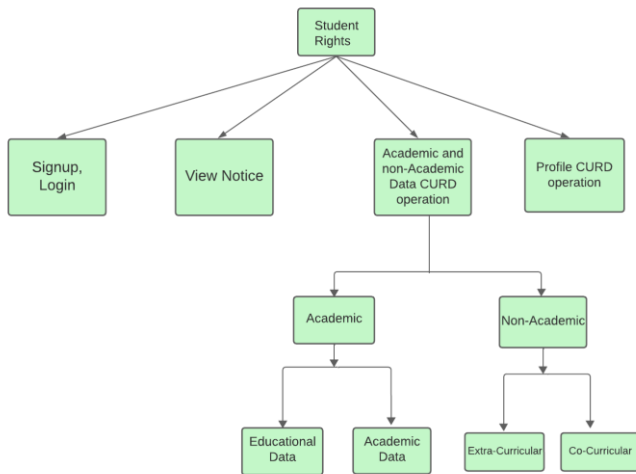

Fig.2. Student's rights

Figure [2] represents rights assigned to the student. Students can upload their profiles, academic data, and co-curricular and extracurricular activities. They are also able to view notices uploaded by the faculty and admin.

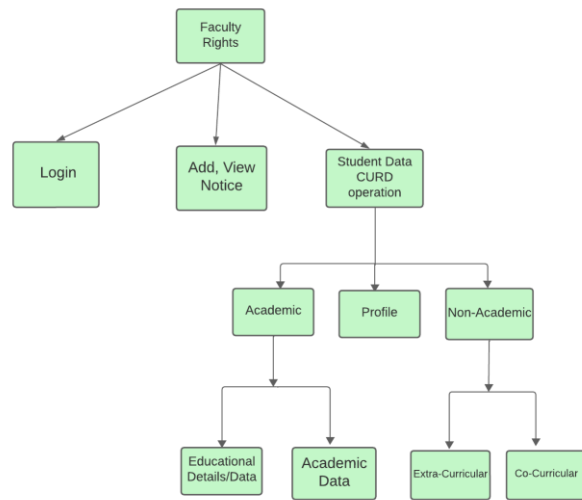

Fig.3. Faculty rights

Figure [3] represents the rights that are assigned to the faculty. This student information system includes a faculty module that allows the faculty to carry out a number of important duties related to their instruction. Upon gaining access to their account, they can specifically browse student profiles that encompass all the necessary information about their students.

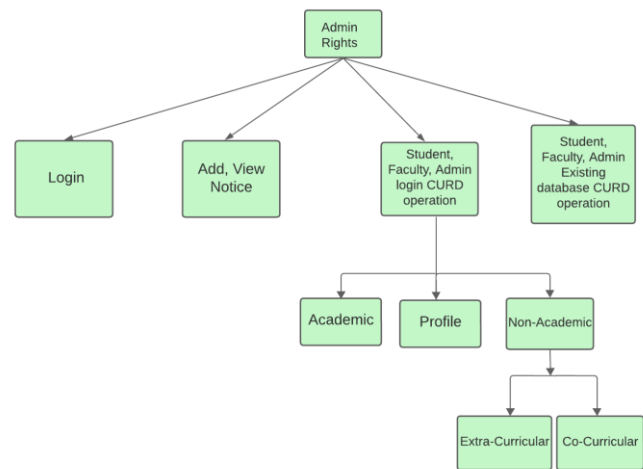

Fig.4. Admin Rights

Figure [4] represents rights assigned to the Admin. Admin can view and add notices and can view and edit the academic and non-academic data of students. Also can view and edit the login credentials of all users.

IV. IMPLEMENTATION

The system has been built using the ASP.NET MVC (Model View Controller) framework. HTML, CSS, and JavaScript are utilized for the front end, while C-sharp programming language is employed for the backend. To manage data storage

and retrieval from the SQL Server database, SQL Server is utilized to store all system data.

Fig.5.OTP validation

Figure [5] illustrates the process of OTP (One-Time Password) validation during the sign-up procedure for new users. The system restricts user registration to email addresses from the "dbit.in" domain, which is the domain associated with the Institute. This limitation ensures that only individuals with valid college affiliations can create accounts within the system.

Fig.6. Admin dashboard

Figure [6] represents the admin dashboard. Where the admin can view and edit the login credentials of other admins, teachers, and students.

Fig.7. Adding notice

Figure [7] represents the form used specifically to add notices to the notice board of the website. This form allows department administrators or authorized personnel to input and submit notices, announcements, or updates relevant to the Department.

Title	Content	Date Published
Result	Result	January 09, 2024 11:57:03 AM
Result	Result will be Displayed on Monday.	November 03, 2023 16:51:38 PM

Fig.8. Noticeboard

Figure [8] represents the noticeboard.

Email	<input type="checkbox"/> Select All
anuj@gmail.com	<input type="checkbox"/>
sharmashiva4423@gmail.com	<input type="checkbox"/>
vivek@gmail.com	<input type="checkbox"/>
sharmashiva4423@gmail.com	<input type="checkbox"/>
121darshan0013@dbit.in	<input type="checkbox"/>
121shivam0019@dbit.in	<input checked="" type="checkbox"/>
100darshan@gmail.com	<input type="checkbox"/>
vivek20@gmail.com	<input type="checkbox"/>
Peonam20@gmail.com	<input type="checkbox"/>
Madhavi20@gmail.com	<input type="checkbox"/>

Fig.9. Selection for email recipients

Figure [9] illustrates the feature enabling the sending of important notices to parents. Within this feature, administrators or faculty members can select the recipients to whom the email will be sent. This functionality allows for targeted communication, ensuring that relevant information reaches the intended recipients efficiently.

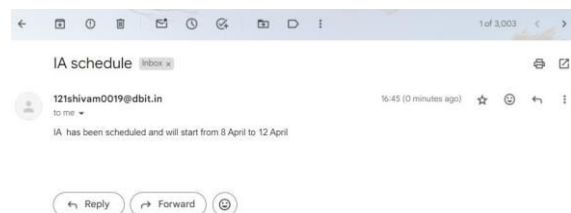

Fig.10. Received mail

Figure [10] shows the mail received by the parent.



Fig.11.Studentdashboard

Figure [11] depicts the student dashboard, providing a centralized interface for students to access and manage their academic and non-academic data. Within this dashboard, students can view their academic records, add new academic data such as grades or coursework, as well as input their curricular and extracurricular activities.

FUTURESCOPE

In the future, access to login credentials can be extended to parents of students, enabling them to monitor their child's academic progress along with his/her participation in events and activities. The system can be extended to encompass features for managing data for attendance along with academic and non-academic records for students. Additionally, administrative features like fees and library management can be incorporated into the system to increase the functionality of the current system.

REFERENCES

- [1] Jhanvi Agarwal, Renuka Singh, Mansi Singh, Mansi Raghav (2020), DEPARTMENT MANAGEMENT SYSTEM, International Journal of Engineering Applied Sciences and Technology.
- [2] Chaitra B. S. (2018), An Innovative Information System for College Management, International Journal of Management, Technology.
- [3] Ms. Swati S. Shintre, Ms. Shubhangi B. Bagul, Ms. Ashwini B. Kanawade, Ms. Shital B. Tajanpure, Mr. Kishor N. Shedge (2020), DEPARTMENT ACTIVITY MANAGEMENT SYSTEM, International Journal of Creative Research Thoughts.
- [4] Sonal J. Patel and Pooja D. Pancholi (2018), Implementation and Comparison of MVC Model in ASP.net Framework and PHP Framework, IJRAR- International Journal of Research and Analytical Reviews.
- [5] Utkarsh Chauhan (2023), E-SHOPPING WEBSITE USING ASP.NET, International Research Journal of Modernization in Engineering Technology and Science [Digests 9th Annual Conf. Magnetics Japan, p. 301, 1982].
- [6] Development of a Student Database Management System for a University (2016), Int. Journal of Engineering Research and Application.
- [7] Student Management System (2021), Deepak Saini, Payal, Mansi Ghadi-gaonkar, Prof. Sujata Kadu. IJARIE.
- [8] College Management System (2016), Srikant Patnaik, Khushboo Kumari Singh, Rashmi Ranjan, Niki Kumari. International Research Journal of Engineering and Technology (IRJET)



National Level Student Conference



"IEEE TECHNICOKNOCKDOWN-2024 (TKD-24)"

Organized by Department of E&TC, SIT Lonavala



Technically Sponsored by IEEE Bombay Section and IETE, Pune Local Center



Supported by IEEE SITSB & IETEISF, SIT Lonavala

April 20, 2024

(Online mode)

Theme: Digital Transformation for Rural Upliftment



Chief Patron

Hon Prof. M. N. Navale, Founder President, STE Society, Pune
Hon Dr. (Mrs) S. M. Navale, Founder Secretary, STE Society, Pune
Hon Ms. Rachana Navale Ashtekar, Vice-President (Admin), STE Society, Pune
Hon Dr. Rohit M. Navale, Vice President (HR), STE Society, Pune

Organizing Chair

Dr. M.S. Gaikwad, Director, STES Campus, Lonavala
Principal, Sinhgad Institute of Technology, Lonavala
Dr. D. S. Mantri, Professor, HoD Dept. of E&TC, Dean Academics, SIT Lonavala Contact: +91-9922431612

Conveners

Dr. P. R. Dike, Asst Professor, Dept. of E&TC, SIT, Lonavala, Contact: +91-9422014174

Coordinator

Mr. M. K. Bhosale, Asst. Professor, Dept. of E&TC, SIT Lonavala [7588628575]

Student Branch Chairs

Sourabh Chakraborty, Chair IEEE SB, Lonavala, Contact: +91- 9834569666
Lokesh Singh, Chair IETE ISF, Lonavala, Contact: +91- 8320247541



Index

"IEEE TECHNICOKNOCKDOWN-2024 (TKD-24)"

Sr.No	Particulars	Page Nos
01	About TKD-24	03
02	Permission Letter	04
03	About STEs	05
04	Vision Mission of Institute and Department	06
05	Call For Papers	09
06	Advisory Board and Organizing Committee	10
07	Inaugural Schedule	12
08	Certificates	13
09	Feedback	17
10	Photographs	18
11	TKD-24 Result Details and Outcome	21



Welcome to TECHNICOKNOCKDOWN-2024

It is our great pleasure to welcome you all for the virtual “TECHNICOKNOCKDOWN-2024 (TKD-24)” National Level Students Conference for technical paper presentation on April 20, 2024. The TKD-24 is organized by Department of Electronics and Telecommunication Engg, Sinhgad Institutes of Technology, Lonavala, Pune, Maharashtra. The conference is technically sponsored by IEEE Bombay Section and IETE, Pune local center and supported by IEEE SITSB and IETEISF, SIT Lonavala. TKD-24 provides an ideal platform for exchange of ideas among researchers, students, and practitioners.

TECHNICOKNOCKDOWN-2024 received research papers from all over India. TKD-24 received more than 55 papers out of which 32 regular papers are selected for the oral presentations after peer review and 25 finally received. The registered and presented papers are published in IEEE TKD-24 proceeding with ISBN No. 978-81-992245-6-7.

We hope that you will find this event interesting and thought provoking. TKD-24 will provide you with a valuable opportunity to share ideas with other researchers, students, and practitioners from institutions. We look forward to the contribution towards the event and see you virtually.

INAUGURAL INVITATION
National Level Student Conference
IEEE TECHNICOKNOCKDOWN -2024
(TKD-24)
Online Mode

THEME: DIGITAL TRANSFORMATION FOR RURAL UPLIFTMENT

DATE : SATURDAY APRIL 20, 2024
TIME : 10:00 AM
Organised by
Department of E&TC Engineering, SIT Lonavala

TECHNICALLY SPONSORED BY
IEEE Bombay Section & IETE Pune Centre
IEEE SIT SB & IETE ISF

LINK : [HTTPS://SHORTURL.AT/CXHIP](https://shorturl.at/cxhip)

Team TECHNICOKNOCKDOWN-2024

**Welcome to National Level Student Conference
IEEE Technicoknockdown-2024 (TKD-24)**

Theme: **Digital Transformation For Rural Upliftment**

Paper registration
<https://forms.gle/3iMHUy711eumqRC47>

Paper Submission : **March 26, 2024**
Acceptance : April 08, 2024
Camera Ready : April 12, 2024
Conference Date : April 20, 2024

Tracks of Conference:
Internet of Things (IoT)
Artificial Intelligence and Machine Learning
Cyber Security
Communication Network
Electrical Vehicle
Media and Signal Processing
Advanced Smart Grids and Power Systems
Robotics and Automation

Registration Fees: 300 rs / Group
Group: Max 4-5 Authors
Proceeding ISBN: No. 978-81-992245-6-7

Join : WhatsApp : <https://chat.whatsapp.com/E9bo63z9QmB8HbKleKGSuO>
Telegram Link : <https://t.me/joinchat/RYPc7BkEbUGTwqfFujDaXQ>

Coordinators: Mr. M. K. Bhosale - 7588628575
Convener: Dr. D. S. Mantri
Dr. P. R. Dike
HOD : Dr. D. D. Chaudhary
Principal: Dr. M. S. Gaikwad

Department of E&TC Engg.
SINHGAD INSTITUTE OF TECHNOLOGY, LONAVALA



5/2/24, 7:37 PM

Gmail - Permission to Organize National Level Student Conference TKD-23



web sit <web.sit42@gmail.com>

Permission to Organize National Level Student Conference TKD-23

3 messages

SIT, Lonavala <web.sit42@gmail.com>

Mon, Feb 26, 2024 at 10:10 AM

To: Sameer S M <sameer@nitc.ac.in>, "Prof. Dr. Shashikant Patil" <sspatil999@gmail.com>

Dear Sir/Madam,

Greetings of the day!!!

The Department of E&TC, Sinhgad Institute of Technology, Lonavala would like to conduct the National level student Conference IEEE TECHNICOKNOCKDOWN-2024 (TKD-24) in association with IEEE SIT SB and IETE ISF student branch. On the theme **Digital Transformation for Rural Upliftment** TechnicoKnockdown-24 is National level conference for students to provide a common platform for exploring their knowledge and skills

The Conference is planned on April 20 ,2024 .We request you to grant permission for using the logo on brochure and certificates. The information brochure is attached herewith for your reference

Waiting for your positive reply.

2 attachments **1. Broucher TKD 24 Final.pdf**
634K **2. TKD-24 Call For Paper.pdf**
853K**Sameer S M** <sameer@nitc.ac.in>

Wed, Apr 10, 2024 at 8:04 PM

To: "SIT, Lonavala" <web.sit42@gmail.com>

Cc: "Prof. Dr. Shashikant Patil" <sspatil999@gmail.com>

Dear Organising Committee Members,

Sorry for the delay in response.

IEEE Bombay Section is happy to extend Technical Co-sponsorship for this program.

Please get in touch with Prof.Shashikant Patil for further guidance.

Regards

Dr Sameer S M

Interim Chair, Bombay Section

[Quoted text hidden]

SIT, Lonavala <web.sit42@gmail.com>

Wed, Apr 10, 2024 at 8:51 PM

To: Sameer S M <sameer@nitc.ac.in>

Cc: "Prof. Dr. Shashikant Patil" <sspatil999@gmail.com>

Dear sir thank you very much for the reply and support

[Quoted text hidden]

About STES:

Sinhgad Technical Education Society (STES) was set up in August 1993, under the able and dynamic leadership of Prof. M.N. Navale with an objective of providing quality education in the field of Engineering, Dentistry, Management, Computer, Pharmacy, Architecture, Hotel Management and the basic school education from kinder garden onwards. There are 58 institutes under the aegis of STES offering full-fledged school education, Diploma, Graduation, Post-Graduation courses and Ph.D. programs in various branches of Engineering, Science and Management at five educational campuses ideally located in pollution free lush green and picturesque environment conducive for learning. (sit.sinhgad.edu).

About SIT, Lonavala

Sinhgad Institute of Technology (SIT), Lonavala since its establishment in 2004 is involved in practicing teaching-learning methodologies of excellence to deliver quality engineering education for students all over India. The institute is housed in beautiful surroundings, fully residential campus of 220 acres on Pune-Mumbai expressway at Lonavala. Academic discipline with space for individual innovations, emphasis on life skill development of students, 'willing to work' team of faculty members and initiative for Industry interface, have been the silent activity of the college. Institute has following branches;

1. E&TC, Engineering
2. Mechanical Engineering,
3. Electrical Engineering,
4. Computer Engineering,
5. Information Technology &
6. Masters in Electrical and Power Systems

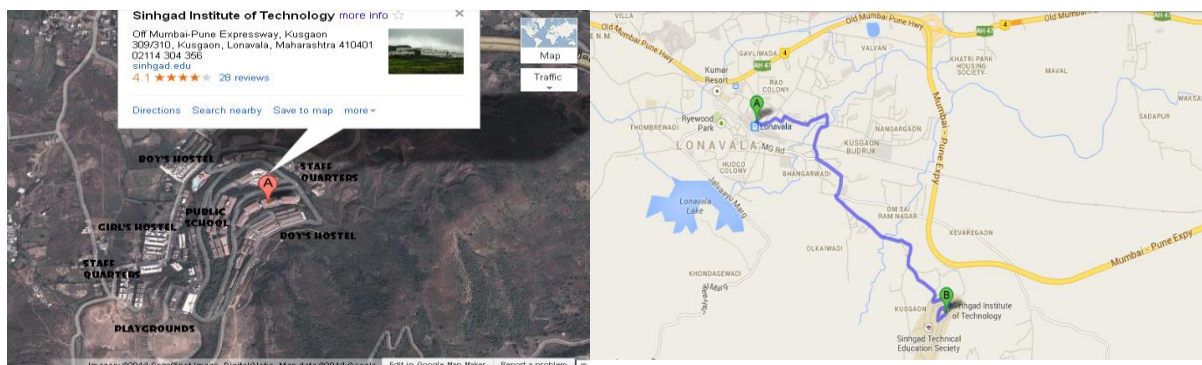



Vision and Mission of the Institute

VISION

उत्तमपुरुषान् उत्तमाभियन्तु निर्मातु कटिबद्धाःवयम्

We are committed to produce not only good engineers but good human beings, also.

MISSION

Holistic development of students and teachers is what we believe in and work for. We strive to achieve this by imbibing a unique value system, transparent work culture, excellent academic and physical environment conducive to learning, creativity & technology transfer. Our mandate is to generate, preserve and share knowledge for developing a vibrant Society.

Quality Policy

Quality Policy is aimed at achieving excellence in Technical Education with recognition at National & International level. Managements is committed to :

- Provide excellent Infrastructure facilities.
- Employ highly qualified & experienced faculty
- Encourage the faculty for qualifications improvement
- Promote the Industry- Institute Interaction
- Create environment for R & D activities, consultation work and getting Industry-sponsored projects for students
- A special internal Quality Assessment Program has been implemented which monitors all the parameters needed for achieving the goals
- Implementation of the Quality Policy will result in all round development of students relevant to the needs of Industries & will make them competent to face the challenges due to Globalization

Vision and Mission of the Department

VISION

The department of Electronics & Telecommunication is committed to grow on a path of delivering distinctive high quality education, fostering research, creativity and innovation.

MISSION

M1: The E&TC Department in partnership with all stake holders will harness talent, potential for application based indigenous product development in future.

M2: Our endeavor is to provide encouraging environment for life skill development of students while exercising effective learning strategies.

M3: We inculcate unique value system based on excellent academics in project based learning among students to explore and solve problems and challenges of realworld applications.



Short Term Goals

- To improve the results of UG classes
- To implement activity plan for overall development of students.
- To establish professional bodies/students forum for life skill development and expose students and faculty to latest business environment.
- To initiate relevant value addition programs and certifications for improving employability.
- To develop Laboratories for meaningful implementation of curriculum and then for Research.
- To encourage continuous up gradation of faculty members through higher education and external interface with other universities.

Long Term Goals

- To practice Project Based Learning (PBL) approach for UG program by creating collaborations with national and International institutions of reputation.
- To create opportunities for students to expose to industry environment through value addition programs and Industry projects for practical training.
- To foster research in the field of Electronics and Telecommunication Engineering for the benefit of society.
- IEEE International conference in the area of Wireless communication.

Program Educational Objectives (PEOs)

- PEO1** To develop students to achieve high level of technical expertise with Strong theoretical background and sound practical knowledge
- PEO2** To inculcate research environment for enhancement of Academia – Industry collaboration through conference
- PEO3** To prepare graduates to be sensitive to ethical, societal and Environmental issues while engaging their professional duties, Entrepreneurship and leadership.
- PEO4** To enhance ability of students for providing Engineering solution in a global and societal context
- PEO5** Pursue higher education for professional development.

Program Specific Outcomes (PSOs)

- PSO1** Get solid foundation in design and development of electronics modules useful to society.
- PSO2** Able to handle skills based challenges

Strength of Department is Faculty Team work to face any challenge

Our Chief Patrons

Sinhgad technical Education Society, Pune



Prof. M. N. Navale
Founder President,
Sinhgad Institutes, Pune



Dr.(Mrs) Sunand M . Navale
Founder Secretary,
Sinhgad Institutes, Pune



Dr.Rohit M. Navale
Vice President (HR),
Sinhgad Institutes, Pune



Ms. Rachana Navale Ashtekar
Vice President (Admin)
Sinhgad Institutes, Pune



Sinhgad Institutes

Sinhgad Technical Education Society's
SINHGAD INSTITUTE OF TECHNOLOGY

(Affiliated to Savitribai Phule Pune University, Pune and Approved by AICTE, New Delhi.)
Gat No. 309/310, Kusaon (Bk), off Mumbai -Pune, Expressway.
Lonavala, Pune, 410401, Website : sit.sinhgad.edu
Accredited by NAAC with Grade "A"



Department of Electronics and Telecommunication Engineering

IEEE TECHNICOKNOCKDOWN 2024(TKD-24)

Student National Conference

April 20, 2024

Theme: **Digital Transformation for Rural Upliftment**Technically Sponsored by IEEE Bombay section and IETE, Pune center
Supported by IEEE SITSB and IETE ISF SIT, Lonavala**VISION**

उत्तमपुरुषान् उत्तमाभियंतृन् निर्मातुं कटीबध्दाः वयम्।

We are committed to produce not only good engineers but good human beings, also.

MISSION

Holistic development of students and teachers is what we believe in and work for. We strive to achieve this by imbibing a unique value system, transparent work culture, excellent academic and physical environment conducive to learning, creativity & technology transfer. Our mandate is to generate, preserve and share knowledge for developing a vibrant Society.

About SIT

Sinhgad Institute of Technology (SIT), Lonavala since its establishment in 2004 is involved in practicing teaching-learning methodologies of excellence to deliver quality engineering education for students all over India. The institute is housed in beautiful surroundings, fully residential campus of 200 acres on Pune-Mumbai expressway at Lonavala. Academic discipline with space for individual innovations, emphasis on life skill development of students, 'willing to work' team of faculty members and initiative for Industry interface, have been the silent activity of the college.

About the Conference

Emerging technologies are characterized by radical novelty relatively fast growth, coherence, prominent impact, and uncertainty and ambiguity. Learning technologies open up significant possibilities for supporting learners. Researchers in the field use the term *affordances* to refer to opportunities that a technology makes possible related to learning and instruction. This in turn creates interest and promote UG and PG students to explore knowledge. The IEEE paper template can be down loaded from <https://www.ieee.org/conferencesevents/conferences/publishing/templates.html>

Tracks of Conference:

1. Internet of Things (IoT)
2. Artificial Intelligence and Machine Learning
3. Cyber Security
4. Communication Network
5. Media and Signal Processing
6. Electrical Vehicle
7. Advanced Smart Grids and Power Systems
8. Robotics and Automation

Note:

- Use IEEE template for paper
- No. of pages : Double Colum 4-5
- Upload paper using registration link
- Accepted and Registered paper will be published in IEEE TKD-24 Proc. with ISBN No. 978-81-992245-6-7

E-certificate with IEEE and IETE Logo will be given to those who presents paper.

Contact Details: Mr. P. R. Dike +9422014174

Mr. M. K. Bhosale +917588628575

Email: web.sit42@gmail.com

- Registration Fees Rs.300/- Per Group (max 4 Members)
- E-certificate will have IEEE & IETE Logo

Chief Patrons**Hon Prof. M. N. Navale**

Founder President, STE Society, Pune

Hon Dr. (Mrs) S. M. Navale

Founder Secretary, STE Society, Pune

Hon Ms. Rachana Navale Ashtekar

Vice-President (Admin), STE Society, Pune

Hon Rohit M. Navale

Vice President (HR), STE Society, Pune

Organizing Chair**Dr. M.S. Gaikwad**

Director, STES Campus, Lonavala

Principal, Sinhgad Institute of Technology,
Lonavala**Dr. D.D. Chaudhary [9372810161]**Vice-Principal, &
HOD, Dept. of E&TC, SIT, Lonavala**Convener****Dr. D.S. Mantri [9922431612]**

Professor, Dept. of E&TC, SIT, Lonavala

Dr. P. R. Dike [9422014174]

Asst. Professor, Dept. of E&TC, SIT, Lonavala

Coordinator**Mr. M. K. Bhosale [7588628575]**

Assoc. Professor, Dept. of E&TC, SIT, Lonavala

Technical Support**Ms. R. D. Mantri**, SIT, Lonavala**Ms. D. S. Mali**, SIT, Lonavala**Ms. S. B. Pandit**, SIT, Lonavala,**Important Dates**

Paper Submission : April 02, 2024

Acceptance : April 08, 2024

Camera Ready : April 12, 2024

Conference Date : April 20, 2024

Link for Registration<https://forms.gle/3iMHUy7j1eumqRC47>**Link for WhatsApp Group**<https://chat.whatsapp.com/E9bo63z9QmB8HbKleKGSuO>**Telegram:**<https://t.me/joinchat/RYPc7BkEbUGTwwFujDaXQ>



Advisory Body and Organizing Committee

Advisory Committee

Dr. Shashikant S Patil, IEEE Bombay Section
 Dr. Vinit Kotak, IEEE Bombay Section
 D. Samir, IEEE Bombay Section
 Mr. Anand Gharpure, IEEE Bombay Section
 Dr. Satyanarayana Bheesette, Immediate past Chair, IEEE Bombay Section
 Mr. Kiran Talele, IEEE Bombay Section
 Dr. Saurabh Mehta, IEEE Bombay Section
 Mr. Dattaraya Sawant, IEEE Bombay Section
 Dr. Sarika Chouhan, Immediate past, Member, Chair SAC, IEEE Bombay Section
 Dr. V. V. Shete, Chairman IETE, Pune local center
 Dr. R. D. Kharadkar, Immediate Past, Chairman IETE, Pune Local Center
 Dr. D. G. Bhalke, Secretary, IETE, Pune Center
 Dr. Sunil Somai, Treasurer, IETE Pune, Local Center
 Mr. S. M. Gaikwad HOD. Mech Dept., SIT Lonavala
 Dr. S. D. Babar HOD, Comp. Dept., SIT Lonavala
 Mr. S. D. Datey HOD, Elect. Dept., SIT Lonavala
 Dr. P. S. Patil HOD, FE Dept., SIT Lonavala
 Dr. R.V. Babar, HOD, IT Dept., SIT Lonavala

Organizing Chairman

Dr. M.S. Gaikwad, Director, STES Campus Lonavala
 Principal, Sinhgad Institute of Technology Lonavala

Convener

Dr. D. S. Mantri, Professor, Dept. of E&TC, SIT Lonavala
 Dr. P. R. Dike, Asst. Prof., Dept. of E&TC, SIT Lonavala

Co-ordinator

Mr. M. K. Bhosale Asst. Prof., Dept. of E&TC, SIT Lonavala

Session Coordinator

Mr. V.D. Raskar, Dept. of E&TC, SIT Lonavala

Publication (Editorial) Committee

Mr. V. M. Chavan, Asst. Prof., Dept. of E&TC, SIT Lonavala
 Mr. Saurabh Chakrawarthy, Student Chairman, IEEE SITSB
 Mr. Lokesh Singh, Student Chairman, IETEISF

Technical Support

Ms. R. D. Mantri, Dept. of Mechanical Engineering, SIT Lonavala
 Ms. D. S. Mali, Dept. of E&TC, SIT Lonavala
 Ms. S. B. Pandit, Dept. of E&TC, SIT Lonavala
 Mr. V. B. Mali, Dept. of E&TC, SIT, Lonavala

Organizing committee

Dr. S. B. Gholap	Ms. C. A. Mhetre	Mr. Shrinivas Wage
Ms. S.S. Patil	Mr. S.S. Salve	Mr. Harshad Bhapkar
Mr. A. A. Labade	Mr. S. S. Asane	Ms. Sejal Mehta
Dr. V.G. Rajeshwarkar	Ms. Shubhanu Muthukumar	Ms. Tanvi Sheety
Ms. S.K. More	Mr. Samarth Kasu	
Mr. S.A. Bhad	Ms. Shivani Kadam	
Ms. P. S. Mhetre	Ms. Shrutika Girhe	
Mr. M.S. Raut	Mr. Harshad Bhapkar	



Dr. M.S. Gaikwad
Principal



Dr. D. S. Mantri
HoD



Dr. P. R. Dike
Convener



Mr. M.K. Bhosale
Coordinator



Ms. Shital K. More
Session Incharge



Dr. V. G. Rajeshwarkar
Session Incharge



Mr. Anand A. Labade
Session Incharge

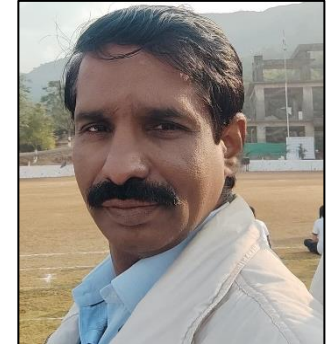

Mr. Vikad D. Raskar
Technical Incharge



Mr. V. M. Chavan
Editor



Dr. V.V. Shete
Chief Guest



Dr. S.S. Patil
Guest of Honour



Dr. Sunil Pandey
Keynote Speaker



Dr. N. P. Kulkarni
Session Chair



Dr. V. M. Rohokale
Session Chair



Prof. H. Ansari
Session Chair



Dr. D.S. Raskar
Session Chair



5/2/24, 8:12 PM

Gmail - Invitation for Keynote Speaker in TKD-24



web sit <web.sit42@gmail.com>

Invitation for Keynote Speaker in TKD-24

1 message

SIT, Lonavala <web.sit42@gmail.com>
To: sunilpandey@its.edu.in

Wed, Apr 17, 2024 at 6:16 PM

Dear Sir ,

INVITATION as Keynote Speaker

“National Level Student Conference, IEEE TECHNICOKNOCKDOWN-2024 (TKD-24).”[Online Mode]

On behalf of Department of E&TC, Sinhgad Institute of Technology, Lonavala, it is an honor and privilege to invite you as a **Keynote Speaker** in the online National Level Student Conference **IEEE TECHNICOKNOCKDOWN-2024 (TKD-24)** with theme “**Digital Transformation for Rural Upliftment**” to be held on April 20, 2022. The TKD-24 is technically sponsored by IEEE Bombay section and IETE, Pune center in association with IEEE SITSB and IETE SIT, Lonavala.

We believe that your contribution to this field is unparalleled. Your expert session is planned on April 20, 2024 from 10.30 am to 11.15 am on topic “**Next Generation Networks: Use of Block chain Technology**” will be of great benefit. It will be pleasure to listen to you.

Thanking You

 1. Dr. Sunil Kr Pandey.pdf
611K

Dr. D. S. Mantri
Convener TKD-24, HOD E&TC

Dr. M. S. Gaikwad
Principal, SIT Lonavala



Sinhgad Institutes

SINHGAD TECHNICAL EDUCATION SOCIETY'S

SINHGAD INSTITUTE OF TECHNOLOGY

Affiliated to Savitribai Phule Pune University, Pune and Approved by, AICTE, New Delhi.

Gat No. 309/310, Off Pune-Mumbai Express Way,
Kusgaon (Bk.) Lonavala-410401. Website: sit.sinhgad.edu

Accredited by NAAC with Grade "A"

PROF. M. N. NAVALE
M.E. (Elect.)MIE, MBA
FOUNDER PRESIDENT

DR. MRS. SUNANDA M. NAVALE
B. A., M. P. M. Ph. D.
SECRETARY

Dr. M. S. GAIKWAD
M. E. Ph. D. (Electronics Engg.)
PRINCIPAL



In Recognition as

Keynote Speaker

This certificate is issued to **Dr. Sunil Kr. Pandey** for Excellent delivery of Content on Topic "**Next Generation Networks: : Using Blockchain Technology**" in the online National Level Student Conference with Theme "**Digital Transformation for Rural Upliftment**", **IEEE TECHNICOKNOCKDOWN-2024** organized by Department of E&TC Engg., Sinhgad Institute of Technology, Lonavala, India, on April 20, 2024. The TKD-24 is Technically Sponsored by IEEE Bombay Section and IETE, Pune Local Center in association with IEEEESB, IETE ISF, SIT Lonavala.



Dr. D. S. Mantri
Convener, TKD-24



Dr. M. S. Gaikwad
Principal, SIT Lonavala



Sinhgad Institutes

Sinhgad Technical Education Society's
SINHGAD INSTITUTE OF TECHNOLOGY

Affiliated to Savitribai Phule Pune University, Pune & Approved by AICTE, New Delhi.
Accredited by NAAC with Grade "A" Website : sit.sinhgad.edu

Department of Electronics and Telecommunication Engineering
TECHNICOKNOCKDOWN-24 (TKD-24)



Ref No. SIT/TKD/2023-24/ 06

Date: 16/04/2024

To,

Dr. V.M. Rohokale,
HOD, Professor,
SITS, Narhe, Pune

INVITATION as Session Chair

“National Level Student Conference, IEEE TECHNICOKNOCKDOWN-2024 (TKD-24).”[Online mode]

On behalf of Department of E&TC, Sinhgad Institute of Technology, Lonavala, it is an honor and privilege to invite you to serve as a **Session Chair** for the track “**Artificial Intelligence and Machine Learning, Cyber security and EV**” in online National Level Student Conference IEEE TECHNICOKNOCKDOWN-2024 (TKD-24) with theme “*Digital Transformation for Rural Upliftment*” to be held on April 20, 2024. The TKD-24 is technically sponsored by IEEE Bombay section and IETE, Pune center in association with IEEE SITSB and IETE SIT, Lonavala.

We believe that your contribution to this field is unparalleled. Your session is planned on April 20, 2024. From 11.30 am to 1.30 pm

Your presence will be highly encouraging to us.

Thanking You



(Dr. D. S. Mantri)

Convener, TKD-24



Session Chair



Certificate of Appreciation

is awarded to

Dr. Dipak S. Raskar

IEEE
TKD-24

for working as a Session Chair in National Level Student Conference,

IEEE TECHNICOKNOCKDOWN - 2024 (TKD-24)

virtually organised by the Department of E&TC Engg, Sinhgad Institute of Technology,
Lonavala Technically Sponsored by IEEE Bombay Section and IETE Pune Local Center

Supported by IEEE SITSB & IETEISF on April 20, 2024.

Dr. D. S. Mantri
Convener IEEE TKD-22

Dr. V. V. Shete
Chair IETE, Pune Center

Dr. M. S. Gaikwad
Principal, SIT Lonavala



Reviewer



Digital Transformation for Rural Upliftment *Certificate of Appreciation*

is awarded to

Dr. B. Satheesh

IEEE
TKD-24

for reviewing a paper at National Level Student Conference,

IEEE TECHNICOKNOCKDOWN - 2024 (TKD-24)

virtually organised by the Department of E&TC Engg, Sinhgad Institute of Technology,
Lonavala Technically Sponsored by IEEE Bombay Section and IETE Pune Local Center

Supported by IEEE SITSB & IETE ISF on April 20, 2024.

Dr. D. S. Mantri
Convener IEEE TKD-24

Dr. V. V. Shete
Chair IETE, Pune Center

Dr. M. S. Gaikwad
Principal, SIT Lonavala



Participation



Digital Transformation for Rural Upliftment

Certificate of Participation

IEEE
TKD-24

is awarded to

Anuj Dhumal

This certificate is awarded for participating in the paper presentation of a paper, **Design of Web based Student Information System** at National Level Student Conference

IEEE TECHNICOKNOCKDOWN - 2024 (TKD-24)

virtually organized by the Department of E&TC Engg, Sinhgad Institute of Technology, Lonavala, Technically Sponsored by IEEE Bombay Section and IETE Pune Local Center

Supported by IEEE SITSB & IETEISF on APRIL 20, 2024.



Dr. P. R. Dike

Convener IEEE TKD-24

Dr. D. S. Mantri

Organising Chair IEEE TKD-24

Dr. V. V. Shete

Chair IETE, Pune Center

Dr. M. S. Gaikwad

Principal, SIT Lonavala

Session Coordinator



Certificate of Appreciation

IEEE
TKD-24

is awarded to

Shubhanu Muthukumar

for working as a Session Coordinator in National Level Student Conference,

IEEE TECHNICOKNOCKDOWN - 2024 (TKD-24)

virtually organised by the Department of E&TC Engg, Sinhgad Institute of Technology, Lonavala Technically Sponsored by IEEE Bombay Section and IETE Pune Local Center

Supported by IEEE SITSB & IETEISF on April 20, 2024.

Dr. D. S. Mantri

Convener IEEE TKD-22

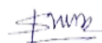
Dr. V. V. Shete

Chair IETE, Pune Center

Dr. M. S. Gaikwad

Principal, SIT Lonavala





Feedback - 27

1. Theme of the Conference

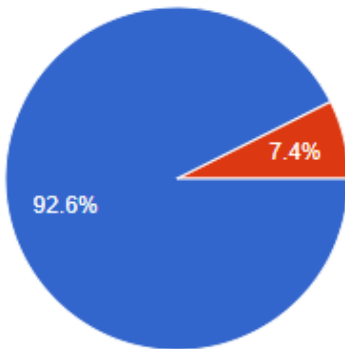

2. Paper review Process

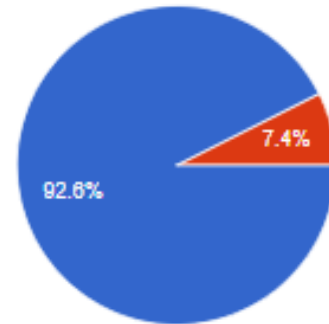

3. Communication by TKD -24 Team

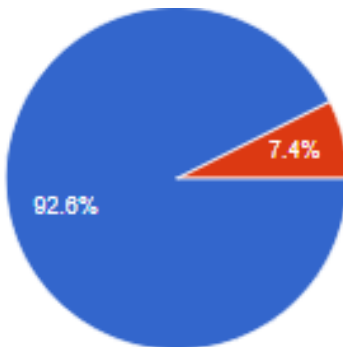

4. Organization and Management of Sessions

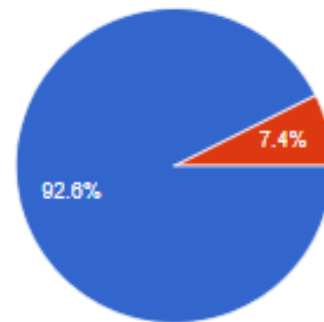

5. Quality of Contents Delivered

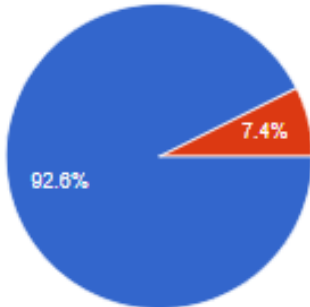

6. Overall Organization of TKD

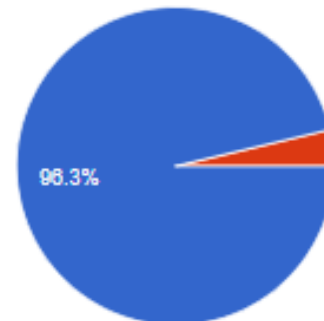

Feedback – keynote session

Knowledge of Expert

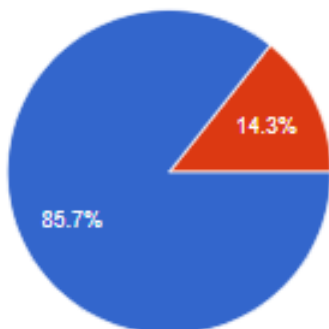

Transparency in Content Delivery

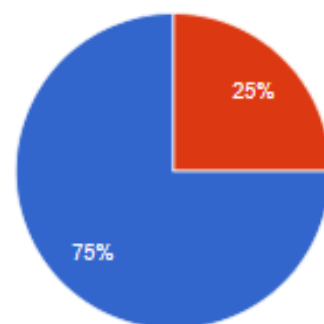



Inauguration of TKD-24

72

TKD2024
29:15 50 attende...

Notifications (1)

Notifications (1)

Welcome to IEEE TKD-24

Dr. M. S. Gaikwad
Director STES Lonavala campus,
Principal, SIT Lonavala
Organizing Chair TKD-24

Dr. Vinit Kotak (External)

Dnyanshwar Mantri

prashant dike

Shubhanu

IRFAN SHAIKH

Dr. Sunil Kr Pandey

Dnyanshwar Mantri

Aditya Ta...
Dr Shashika...
Shubhanu

VR VIKAS R
SS SE A 32-R...
DR Dipak Ra...
DM



Inauguration

The screenshot displays a Zoom meeting interface for the inauguration of IEEE TKD-24. The top left shows a 'Notifications (1)' banner. The main grid features several participants: Dr. Vinit Kotak (External), Aditya Tayade, Vikram chavan, prashant dike, IRFAN SHAIKH, and Dr. Sunil Kr Pandey. A 'DM' (Direct Message) button is visible. Below the grid are controls for video, audio, and chat. On the right, a 'TKD2024' banner indicates 27:14 duration and 52 attendees, with a 'Guests are waiting to join. View lobby' notification. A 'Thank You' slide from Mr. Prashant R. Dike, Convener of IEEE TKD-24, is shown, along with logos for IEEE and Sinhgad Institute of Technology, Lonavala. Below this, a 'Welcome to IEEE TKD-24' slide from Dr. D. S. Mantri, Convener of IEEE TKD-24, is displayed, listing his title as Professor, HoD Dept. of E&TC, Dean Academics, SIT Lonavala, and Vice Chair, IETE Pune Local Center. A 'Participants' list on the right side of the screen includes names like AAS SHUBHAM MITHERKUMAR, Aditya Tayade, Anag Dhawal, Anurag Saw, Ashish Dahi, Atharva Mantri, Dipak Raskar, Dnyaneshwar Mantri, and Dnyaneshwar M. Mantri.

Key Note Speaker

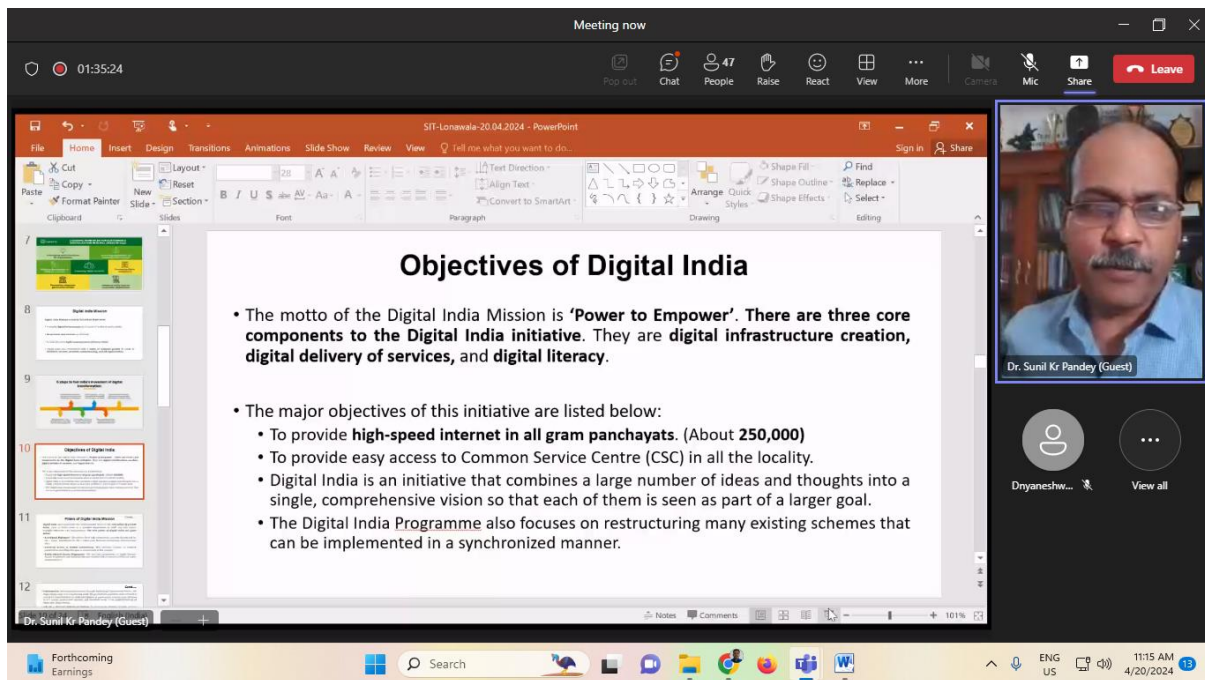

Meeting now

01:35:24

Pop out Chat People Raise React View More Camera Mic Share Leave

SIT-Lonavala-20.04.2024 - PowerPoint

File Home Insert Design Transitions Animations Slide Show Review View Tell me what you want to do...

Layout - Reset New Slide - Section - Clipboard - Paste - Copy - Format Painter - Font - Paragraph - Drawing - Shape Fill - Shape Outline - Shape Effects - Find - Replace - Select

Objectives of Digital India

- The motto of the Digital India Mission is 'Power to Empower'. There are three core components to the Digital India initiative. They are digital infrastructure creation, digital delivery of services, and digital literacy.
- The major objectives of this initiative are listed below:
 - To provide **high-speed internet in all gram panchayats**. (About 250,000)
 - To provide easy access to Common Service Centre (CSC) in all the locality.
 - Digital India is an initiative that combines a large number of ideas and thoughts into a single, comprehensive vision so that each of them is seen as part of a larger goal.
 - The Digital India Programme also focuses on restructuring many existing schemes that can be implemented in a synchronized manner.

Dr. Sunil Kr Pandey (Guest)

Dnyaneshw... View all

ENG US 11:15 AM 4/20/2024

Session Photos

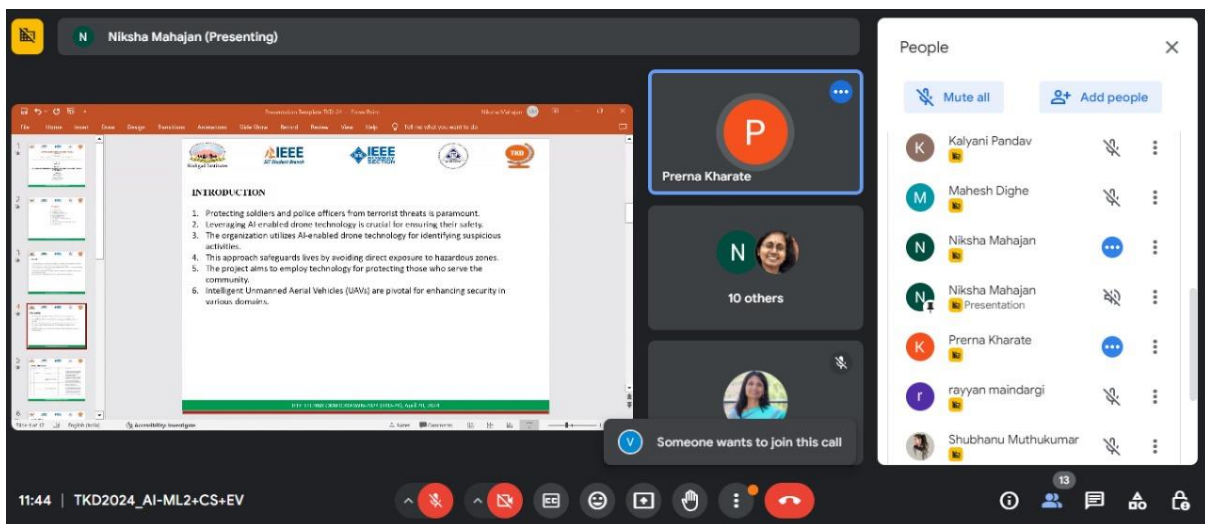

N Niksha Mahajan (Presenting)

People

Mute all Add people

Kalyani Pandav

Mahesh Dighe

Niksha Mahajan

Niksha Mahajan Presentation

Purna Kharate

rayyan maindargi

Shubhanu Muthukumar

10 others

Someone wants to join this call

11:44 | TKD2024_AI-ML2+CS+EV

INTRODUCTION

- Protecting soldiers and police officers from terrorist threats is paramount.
- Leveraging AI enabled drone technology is crucial for ensuring their safety.
- The organization utilizes AI-enabled drone technology for identifying suspicious activities.
- This approach safeguards lives by avoiding direct exposure to hazardous zones.
- The project aims to employ technology for protecting those who serve the community.
- Intelligent Unmanned Aerial Vehicles (UAVs) are pivotal for enhancing security in various domains.



IEEE TKD-24 Details

A. Paper Details

Sr	Track	Original	Accept	MIR	MJR	Reject	Total	Accepted	Registered
1	AIML	18	5	8	3	2	18	16	10
2	ASGSP	1	1	0	0	0	0	1	01
3	CN	4	1	0	1	2	4	2	02
4	IoT	11	3	4	1	3	11	8	03
5	CS	1	0	1	0	0	1	1	01
6	others	10	2	6	1	1	10	9	07
7	R&A	2	0	2	0	0	2	2	00
8	EV	1	1	0	0	0	1	1	01
Total		48	13	21	6	8	47	40	25

B. Participants: More than 150 Students and faculty

C. Session Details

Session	Track	Student Coordinator	Session Coordinators	Name of Session Chair
Keynote Speaker		Dr. Sunil Kr. Pandey, Director ITS Ghaziabad		
I	AIML-1	Ms. Shrutika Girhe	Dr.V.G.Rajeshwarkar	Prof. Abdul H. Ansari
II	AIML+ CS+EV	Shubhanu Muthukumar	Mrs. Shital K. More	Dr.Vandana M.Rohokale
III	ASGP+CN+ IOT	Tanmay Dharmik	Mr.Anand Labade	Dr. Nandkumar P. Kulkarni
IV	Others	Tanvi Shetty	Dr.Prashant R.Dike	Dr. Deepak S.Raskar

Outcome:

TKD -24 is a national level Student conference hosted by department of E&TC Engg. Key note address on **“Next Generation Network: Using Blockchain Technology”** opened many opportunities in research field. In all, 26 research papers were presented in various emerging Technological fields and shared the knowledge among 150 students and faculty members.

Lonavala Prides

Karla Caves

Karla Caves is one of the oldest Buddhist cave shrines in India and one of the most fascinating places to visit in Lonavala. The caves are carved on a rocky hillside and they date back to the 2nd and the 5th century BC. The caves are divided into several sections as halls and monasteries.



Lohagad Fort

Lohagad Fort (Iron Fort) is a historical fort situated along the Sahyadri hills in the Lonavala region of Maharashtra. It is one of the best tourist places to visit in Lonavala and also one of the popular heritage in Maharashtra.



EVENTS ORGANIZED BY IEEE SIT SB



**STEM WORKSHOP
(ANTRIKSH)**



VIVID UI WORKSHOP



**HACKSTREET CODING
COMPETITION**